

JVC

SERVICE MANUAL

DVD PLAYER/Hi-Fi STEREO KARAOKE VIDEO CASSETTE PLAYER

HR-XV10AG

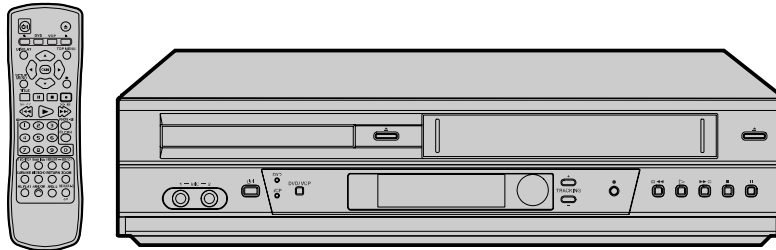

SPECIFICATIONS

General

Power requirements	AC 110-240V , 50/60 Hz
Power consumption	20W
Dimensions (approx.)	430 X 97.5 X 360 mm (w/h/d)
Mass (approx.)	5.3 kg
Operating temperature	5°C to 35°C
Operating humidity	5 % to 90 %

System

Laser	Semiconductor laser, wavelength 650 nm
Video Head system	Double azimuth 4 heads, helical scanning.
Signal system	PAL/NTSC
Frequency response	DVD (PCM 96 kHz): 2 Hz to 44 kHz DVD (PCM 48 kHz): 2 Hz to 22 kHz CD: 2 Hz to 20 kHz
Signal-to-noise ratio	More than 100dB (ANALOG OUT connectors only)
Harmonic distortion	Less than 0.008%
Dynamic range	More than 95 dB (DVD) More than 95 dB (CD)
Wow and flutter	Less than detected value ($\pm 0.001\%$ W PEAK)

Inputs (VCP)

Audio	-6.0dBm, more than 47 kohms
Video	1.0 Vp-p, 75 ohms, unbalanced

Outputs (DVD)

VIDEO OUT	1 Vp-p 75 ohms, sync negative
COMPONENT VIDEO OUT	(Y) 1.0 V (p-p), 75 Ω , negative sync., RCA jack x 1 (Pb)/(Pr) 0.7 V (p-p), 75 Ω , RCA jack x 2
Audio output (digital audio)	0.5 V (p-p), 75 Ω , RCA jack x 1
Audio output (analog audio)	2.0 Vrms (1 KHz, 0 dB), 330 Ω , RCA jack (L, R)

Outputs (VCP/DVD)

Audio	-6.0dBm, less than 1 kohms
Video	1.0 Vp-p, 75 ohms, unbalanced

Manufactured under license from Dolby Laboratories. "Dolby" and the double-D symbol are trademarks of Dolby Laboratories. Confidential unpublished works. Copyright 1992-1997 Dolby Laboratories. All rights reserved.

"DTS" and "DTS Digital Out" are trademarks of Digital Theater Systems, Inc.

■ Design and specifications are subject to change without notice.

HR-XV10AG D2VP11E

COPYRIGHT © 2003 VICTOR COMPANY OF JAPAN, LTD

No.82959
2003/02

CONTENTS

SECTION 1SUMMARY

SECTION 2CABINET & MAIN CHASSIS

SECTION 3ELECTRICAL

SECTION 4MECHANISM OF VCR PART

SECTION 5MECHANISM OF DVD PART

SECTION 6REPLACEMENT PARTS LIST

SECTION 1

SUMMARY

CONTENTS

Important safety precautions	1-3
SPECIFICATIONS	1-5

Important Safety Precautions

Prior to shipment from the factory, JVC products are strictly inspected to conform with the recognized product safety and electrical codes of the countries in which they are to be sold. However, in order to maintain such compliance, it is equally important to implement the following precautions when a set is being serviced.

●Precautions during Servicing

1. Locations requiring special caution are denoted by labels and inscriptions on the cabinet, chassis and certain parts of the product. When performing service, be sure to read and comply with these and other cautionary notices appearing in the operation and service manuals.

2. Parts identified by the \triangle symbol and shaded (■) parts are critical for safety.
Replace only with specified part numbers.
Note: Parts in this category also include those specified to comply with X-ray emission standards for products using cathode ray tubes and those specified for compliance with various regulations regarding spurious radiation emission.

3. Fuse replacement caution notice.
Caution for continued protection against fire hazard.
Replace only with same type and rated fuse(s) as specified.

4. Use specified internal wiring. Note especially:
1) Wires covered with PVC tubing
2) Double insulated wires
3) High voltage leads

5. Use specified insulating materials for hazardous live parts. Note especially:
1) Insulation Tape 3) Spacers 5) Barrier
2) PVC tubing 4) Insulation sheets for transistors

6. When replacing AC primary side components (transformers, power cords, noise blocking capacitors, etc.) wrap ends of wires securely about the terminals before soldering.

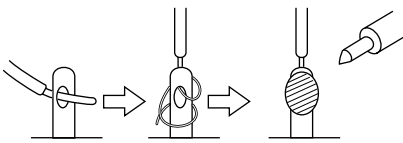

Fig.1

7. Observe that wires do not contact heat producing parts (heatsinks, oxide metal film resistors, fusible resistors, etc.)

8. Check that replaced wires do not contact sharp edged or pointed parts.

9. When a power cord has been replaced, check that 10-15 kg of force in any direction will not loosen it.

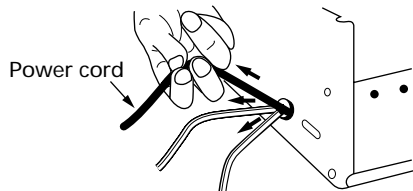

Fig.2

10. Also check areas surrounding repaired locations.

11. Products using cathode ray tubes (CRTs)
In regard to such products, the cathode ray tubes themselves, the high voltage circuits, and related circuits are specified for compliance with recognized codes pertaining to X-ray emission. Consequently, when servicing these products, replace the cathode ray tubes and other parts with only the specified parts. Under no circumstances attempt to modify these circuits. Unauthorized modification can increase the high voltage value and cause X-ray emission from the cathode ray tube.

12. Crimp type wire connector
In such cases as when replacing the power transformer in sets where the connections between the power cord and power transformer primary lead wires are performed using crimp type connectors, if replacing the connectors is unavoidable, in order to prevent safety hazards, perform carefully and precisely according to the following steps.

- 1) **Connector part number** : E03830-001
- 2) **Required tool** : Connector crimping tool of the proper type which will not damage insulated parts.
- 3) **Replacement procedure**
 - (1) Remove the old connector by cutting the wires at a point close to the connector.
Important : Do not reuse a connector (discard it).

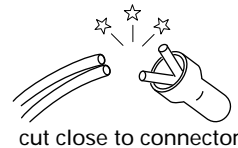

Fig.3

- (2) Strip about 15 mm of the insulation from the ends of the wires. If the wires are stranded, twist the strands to avoid frayed conductors.

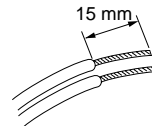

Fig.4

- (3) Align the lengths of the wires to be connected. Insert the wires fully into the connector.

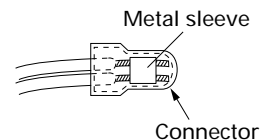

Fig.5

- (4) As shown in Fig.6, use the crimping tool to crimp the metal sleeve at the center position. Be sure to crimp fully to the complete closure of the tool.

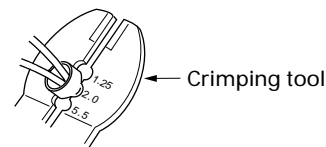

Fig.6

- (5) Check the four points noted in Fig.7.

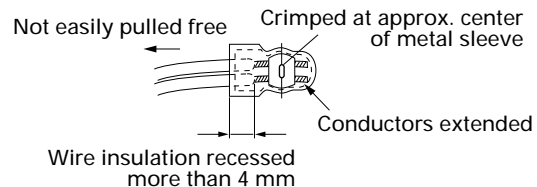

Fig.7

● Safety Check after Servicing

Examine the area surrounding the repaired location for damage or deterioration. Observe that screws, parts and wires have been returned to original positions. Afterwards, perform the following tests and confirm the specified values in order to verify compliance with safety standards.

1. Insulation resistance test

Confirm the specified insulation resistance or greater between power cord plug prongs and externally exposed parts of the set (RF terminals, antenna terminals, video and audio input and output terminals, microphone jacks, earphone jacks, etc.). See table 1 below.

2. Dielectric strength test

Confirm specified dielectric strength or greater between power cord plug prongs and exposed accessible parts of the set (RF terminals, antenna terminals, video and audio input and output terminals, microphone jacks, earphone jacks, etc.). See table 1 below.

3. Clearance distance

When replacing primary circuit components, confirm specified clearance distance (d), (d') between soldered terminals, and between terminals and surrounding metallic parts. See table 1 below.

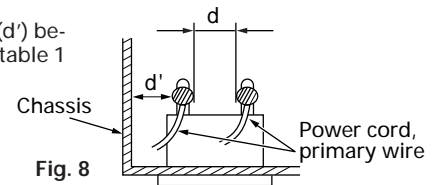

4. Leakage current test

Confirm specified or lower leakage current between earth ground/power cord plug prongs and externally exposed accessible parts (RF terminals, antenna terminals, video and audio input and output terminals, microphone jacks, earphone jacks, etc.).

Measuring Method : (Power ON)

Insert load Z between earth ground/power cord plug prongs and externally exposed accessible parts. Use an AC voltmeter to measure across both terminals of load Z. See figure 9 and following table 2.

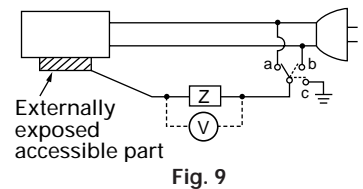

5. Grounding (Class I model only)

Confirm specified or lower grounding impedance between earth pin in AC inlet and externally exposed accessible parts (Video in, Video out, Audio in, Audio out or Fixing screw etc.).

Measuring Method:

Connect milli ohm meter between earth pin in AC inlet and exposed accessible parts. See figure 10 and grounding specifications.

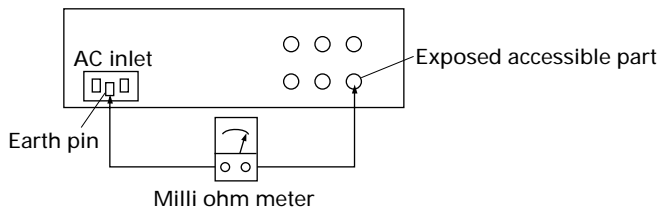

Grounding Specifications

Region	Grounding Impedance (Z)
USA & Canada	$Z \leq 0.1 \text{ ohm}$
Europe & Australia	$Z \leq 0.5 \text{ ohm}$

Fig. 10

AC Line Voltage	Region	Insulation Resistance (R)	Dielectric Strength	Clearance Distance (d), (d')
100 V	Japan	$R \geq 1 \text{ M}\Omega/500 \text{ V DC}$	AC 1 kV 1 minute	$d, d' \geq 3 \text{ mm}$
100 to 240 V			AC 1.5 kV 1 minute	$d, d' \geq 4 \text{ mm}$
110 to 130 V	USA & Canada	$1 \text{ M}\Omega \leq R \leq 12 \text{ M}\Omega/500 \text{ V DC}$	AC 1 kV 1 minute	$d, d' \geq 3.2 \text{ mm}$
110 to 130 V	Europe & Australia	$R \geq 10 \text{ M}\Omega/500 \text{ V DC}$	AC 3 kV 1 minute (Class II)	$d \geq 4 \text{ mm}$
200 to 240 V			AC 1.5 kV 1 minute (Class I)	$d' \geq 8 \text{ mm}$ (Power cord) $d' \geq 6 \text{ mm}$ (Primary wire)

Table 1 Specifications for each region

AC Line Voltage	Region	Load Z	Leakage Current (i)	a, b, c
100 V	Japan		$i \leq 1 \text{ mA rms}$	Exposed accessible parts
110 to 130 V	USA & Canada		$i \leq 0.5 \text{ mA rms}$	Exposed accessible parts
110 to 130 V 220 to 240 V	Europe & Australia		$i \leq 0.7 \text{ mA peak}$ $i \leq 2 \text{ mA dc}$	Antenna earth terminals
			$i \leq 0.7 \text{ mA peak}$ $i \leq 2 \text{ mA dc}$	Other terminals

Table 2 Leakage current specifications for each region

Note: These tables are unofficial and for reference only. Be sure to confirm the precise values for your particular country and locality.

SPECIFICATIONS

DVD PART

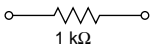
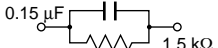
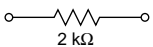
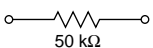
Power requirements	AC 110-240V , 50/60 Hz
Power consumption	20W
Dimensions (approx.)	430 X 97.5 X 360 mm (w/h/d)
Mass (approx.)	5.4 kg
Operating temperature	5°C to 35°C (41°F to 95°F)
Operating humidity	5 % to 90 %

SYSTEM

Laser	Semiconductor laser, wavelength 650 nm
Video Head system	Double azimuth 4 heads, helical scanning.
Signal system	PAL/NTSC
Frequency response	DVD (PCM 96 kHz): 2 Hz to 44 kHz DVD (PCM 48 kHz): 2 Hz to 22 kHz CD: 2 Hz to 20 kHz
Signal-to-noise ratio	More than 100dB (ANALOG OUT connectors only)
Harmonic distortion	Less than 0.008%
Dynamic range	More than 95 dB (DVD) More than 95 dB (CD)
Wow and flutter	Less than detected value ($\pm 0.001\%$ W PEAK)

INPUT

Audio	-6.0dBm, more than 47 kohms
Video	1.0 Vp-p, 75 ohms, unbalanced

OUTPUTS

VIDEO OUT	1 Vp-p 75 ohms, sync negative
COMPONENT VIDEO OUT	(Y) 1.0 V (p-p), 75 Ω , negative sync., RCA jack x 1 (Pb)/(Pr) 0.7 V (p-p), 75 Ω , RCA jack x 2
Audio output (digital audio)	0.5 V (p-p), 75 Ω , RCA jack x 1
Audio output (analog audio)	2.0 Vrms (1 KHz, 0 dB), 330 Ω , RCA jack (L, R)

*Design and specifications are subject to change without notice.

SECTION 2
CABINET & MAIN CHASSIS
CONTENTS

1. EXPLODED VIEWS2-2

1. Cabinet and Main Frame Section2-2

2. Packing Accessory Section2-3

EXPLODED VIEWS

1. Cabinet and Main Frame Section

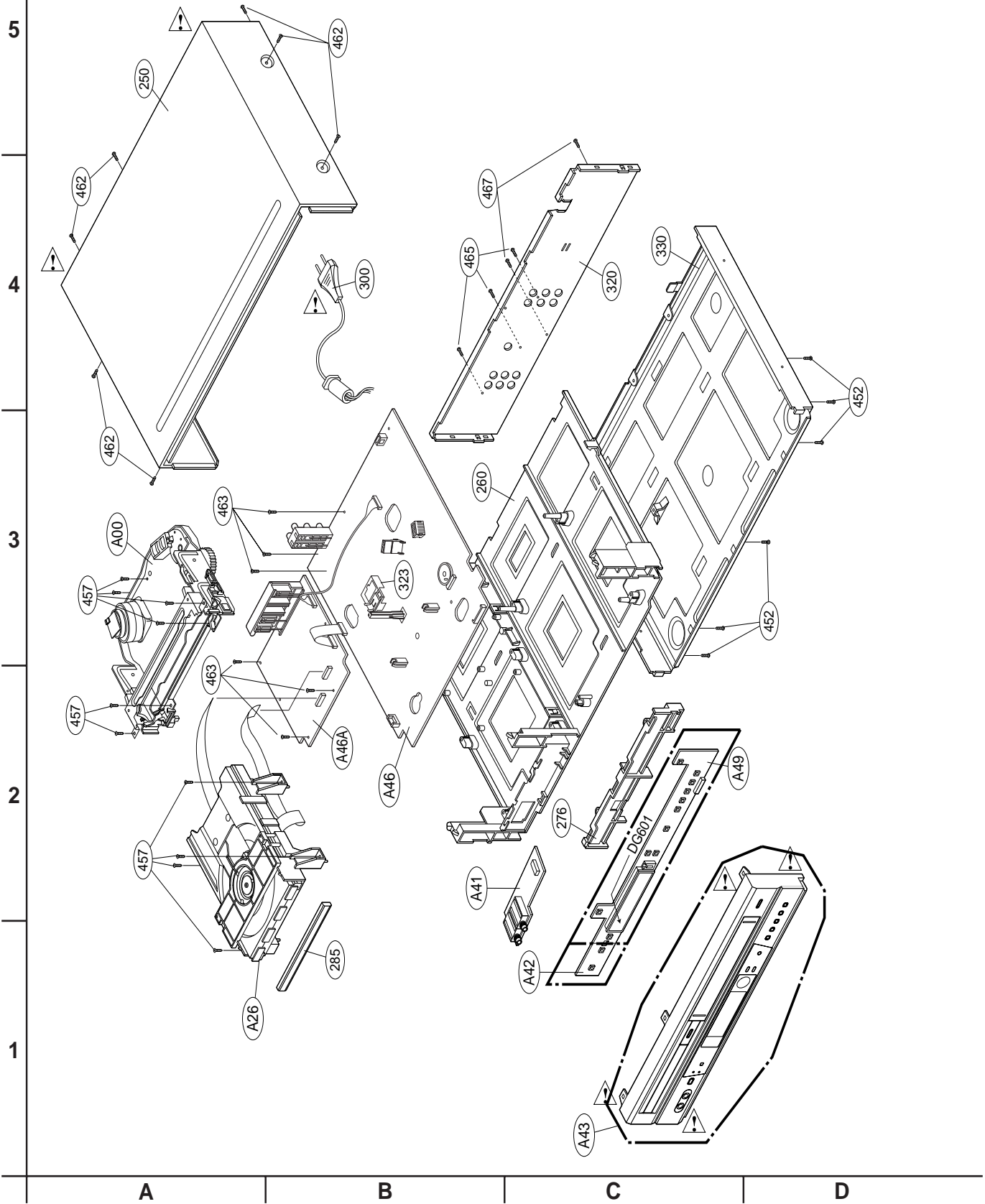

2.Packing Accessory Section

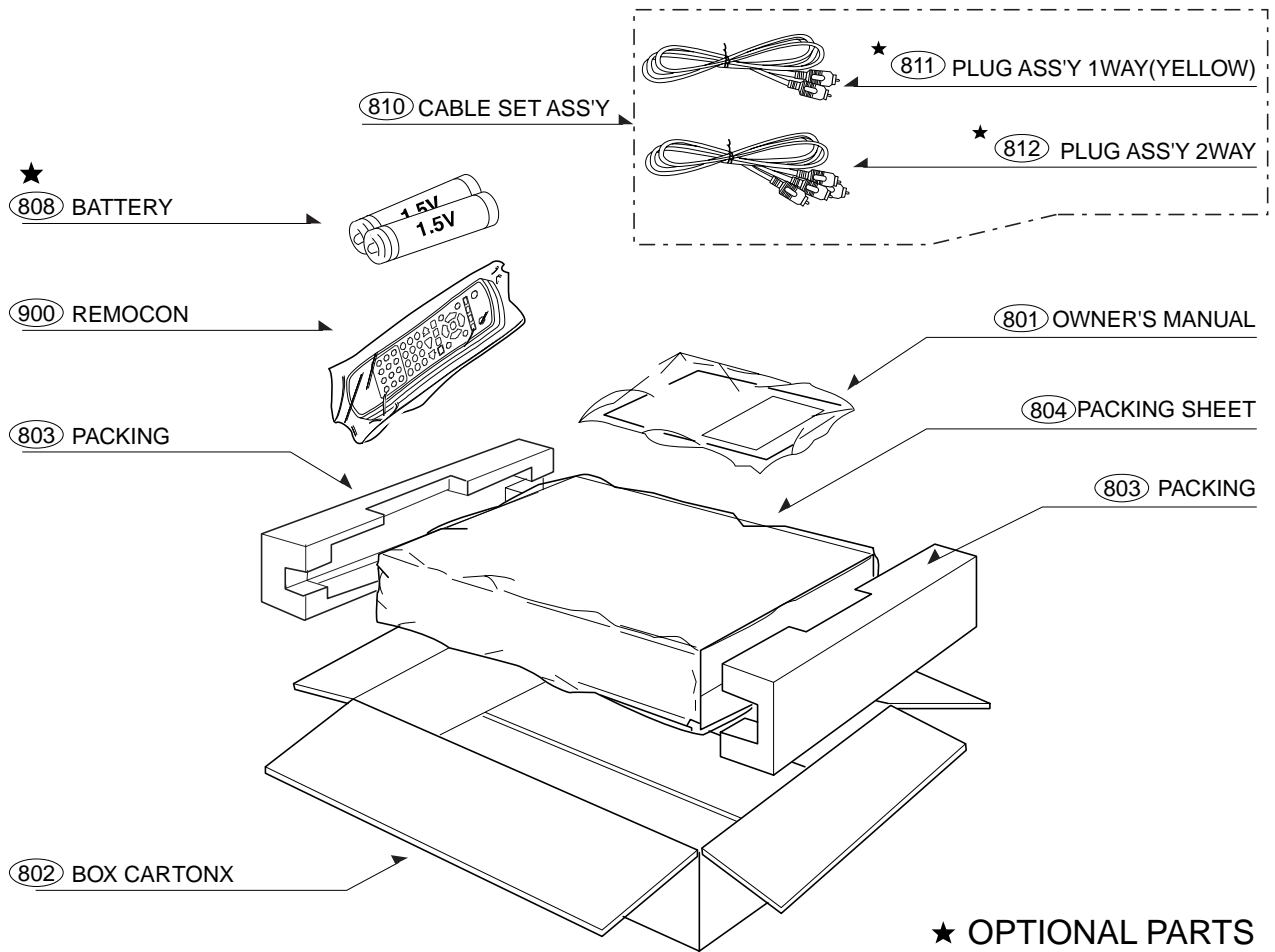

SECTION 3 ELECTRICAL CONTENTS

OVERALL BLOCK DIAGRAM	3-2
VCR PART	
ELECTRICAL ADJUSTMENT PROCEDURES	3-3
ELECTRICAL TROUBLESHOOTING GUIDE	3-4
1. POWER(SMPS) Circuit	3-4
2. SYSTEM/KEY CIRCUIT	3-7
3. SERVO CIRCUIT.....	3-8
4. OSD CIRCUIT	3-10
5. Y/C CIRCUIT	3-11
6. Hi-Fi CIRCUIT	3-15
7. KARAOKE CIRCUIT.....	3-18
BLOCK DIAGRAMS	3-20
1. Power (SMPS) Block Diagram	3-20
2. KARAOKE Block DIAGRAM	3-22
3. Y/C Block Diagram	3-24
4. NORMAL AUDIO Block Diagram	3-26
5. Hi-Fi Block Diagram(Hi-Fi PART)	3-28
6. SYSTEM Block Diagram.....	3-30
CIRCUIT DIAGRAMS	3-32
1. Power (SMPS) Circuit Diagram	3-32
2. KARAOKE Circuit Diagram.....	3-34
3. A/V Circuit Diagram	3-36
4. Hi-Fi Circuit Diagram.....	3-38
5. SYSTEM Circuit Diagram	3-40
• WAVEFORMS	3-42
• CIRCUIT VOLTAGE CHART	3-44
PRINTED CIRCUIT DIAGRAMS	3-46
1. MAIN P.C.BOARD.....	3-46
2. KARAOKE P.C.BOARD.....	3-48
3. KEY P.C.BOARD.....	3-48
4. CLOCK P.C.BOARD	3-49
DVD PART	
ELECTRICAL TROUBLESHOOTING GUIDE	3-50
1. μ -COM CIRCUIT	3-50
2. MPEG CIRCUIT	3-53
3. RF/Servo CIRCUIT	3-54
BLOCK DIAGRAMS	3-58
1. DVD Overall BLOCK DIAGRAM.....	3-58
2. RF/CD DSP/DVD DSP/DVD SERVO BLOCK DIAGRAM	3-59
3. Audio BLOCK DIAGRAM	3-60
4. MPEG BLOCK DIAGRAM	3-61
CIRCUIT DIAGRAMS	3-62
1. DVD DSP CIRCUIT DIAGRAM.....	3-62
2. DRIVE & RF CIRCUIT DIAGRAM	3-64
3. MPEG CIRCUIT DIAGRAM	3-66
4. Audio DM CIRCUIT DIAGRAM	3-68
5. MEMORY CIRCUIT DIAGRAM.....	3-70
6. SCART(JACK) CIRCUIT DIAGRAM	3-72
• WAVEFORMS	3-74
• CIRCUIT VOLTAGE CHART	3-76
PRINTED CIRCUIT DIAGRAMS	3-80
1. MAIN P.C.BOARD (TOP VIEW).....	3-80
1. MAIN P.C.BOARD (BOTTOM VIEW)	3-82

VCR PART

ELECTRICAL ADJUSTMENT PROCEDURES

1. Servo Adjustment

- 1) PG Adjustment
 - Test Equipment

a) OSCILLOSCOPE	C) PAL MODEL : PAL SP TEST TAPE
b) NTSC MODEL : NTSC SP TEST TAPE	

- Adjustment And Specification

MODE	MEASUREMENT POINT	ADJUSTMENT POINT	SPECIFICATION
PLAY	V.Out H/SW(W373, W374)	R/C TRK JIG KEY	$6.5 \pm 0.5H$

• Adjustment Procedure

- a) Insert the SP Test Tape and play.
 Note - Adjust the distance of X, pressing the Tracking(+) or Tracking(-) when the "ATR" is blink after the SP Test Tape is inserted.
- b) Connect the CH1 of the oscilloscope to the H/SW(W373, W374) and CH2 to the Video Out for the VCR.
- c) Trigger the mixed Combo Video Signal of CH2 to the CH1 H/SW(W373, W374), and then check the distance (time difference), which is from the selected A(B) Head point of the H/SW(W373, W374) signal to the starting point of the vertical synchronized signal, to $6.5H \pm 0.5H$ ($412\mu s$, $1H=63\mu s$).

• PG Adjustment Procedure

- a) Payback the SP standard tape
- b) Press the "1" key on the Remote controller and the "PLAY" key on the Front Panel the same time, then it goes in to Tracking initial mode. (Note: NTSC Model : "1" key and PAL Model "0" key on Remote controller)
- c) Repeat the above step(No.2), then it finishes the PG adjusting automatically.
- d) Stop the playback, then it goes out to PG adjusting mode after many the PG data.

• CONNECTION

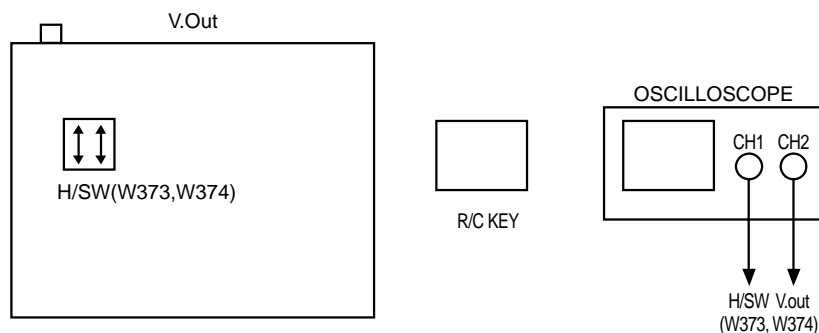

• WAVEFORM

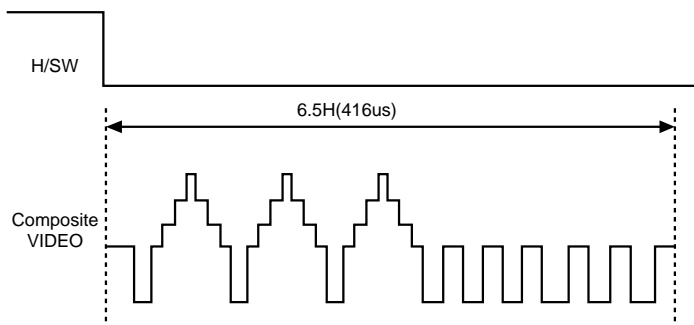

ELECTRICAL TROUBLESHOOTING GUIDE

1. Power(SMPS) CIRCUIT

(1) No 5.3VA (SYS/Hi-Fi/TUNER)

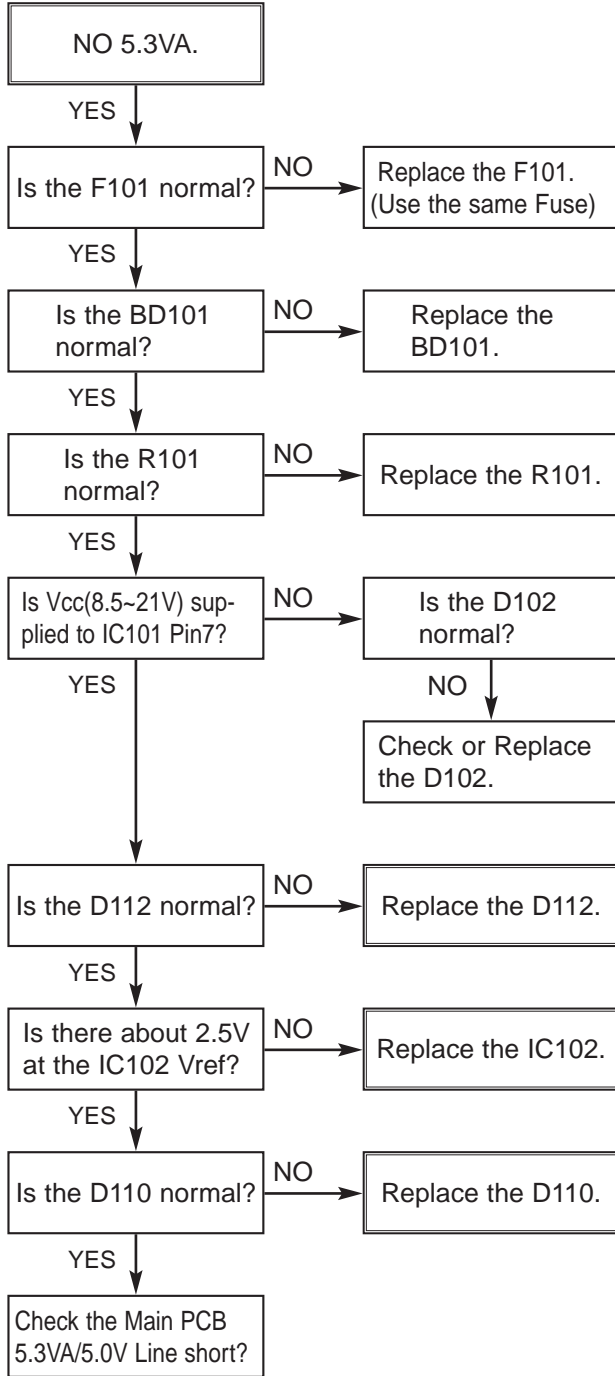

(2) No 12VA (TO CAP, DRUM MOTOR)

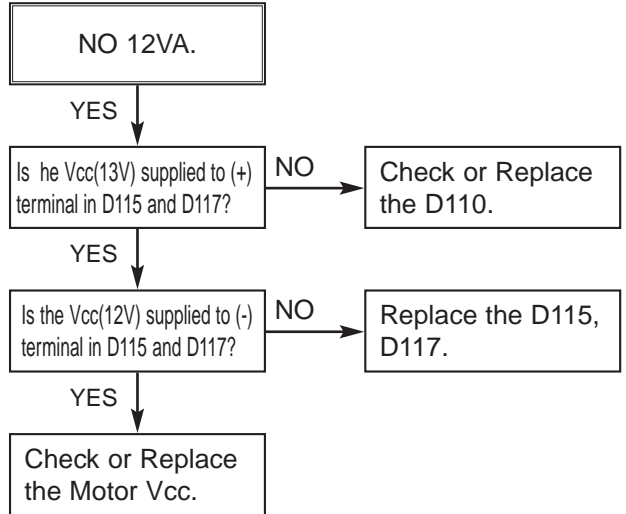

(3) No 5.2V (SYS/Hi-Fi/TUNER)

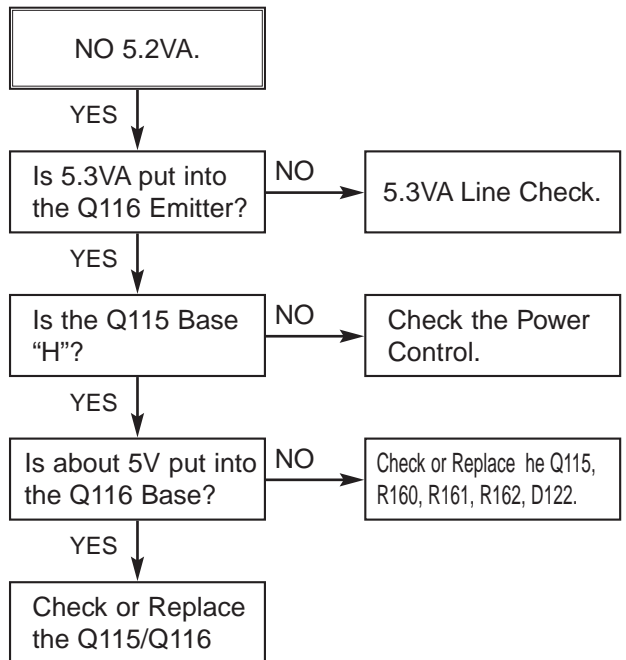

(4) No 5V (TO DVD)

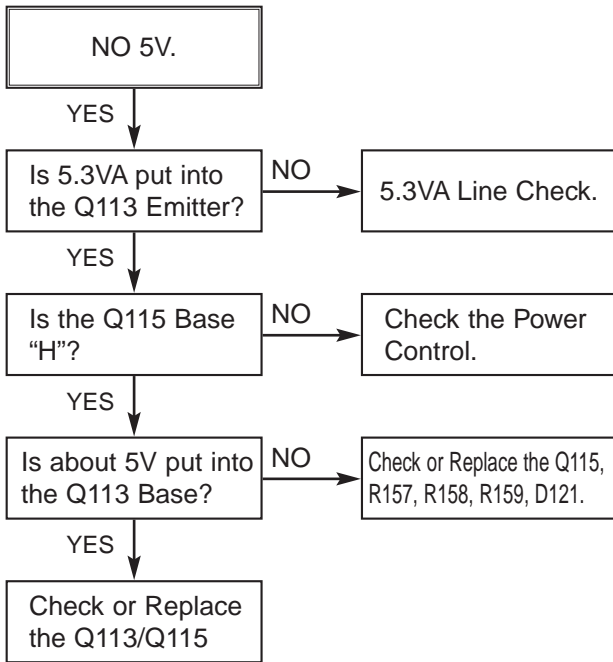

(5) No REG 5V (AVCP)

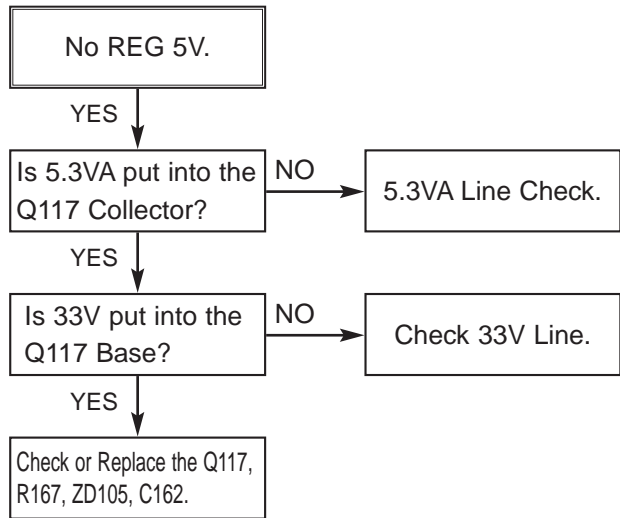

(6) No 33V (TUNER)

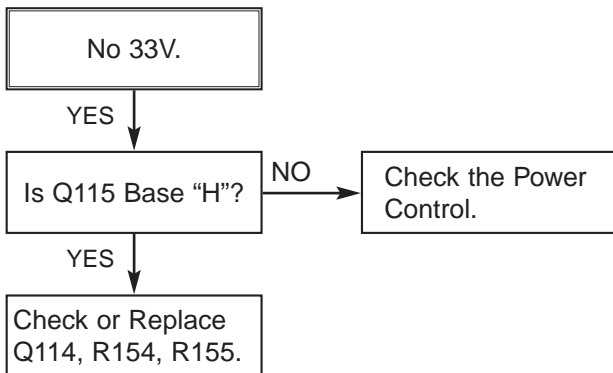

(7) No REG 12V

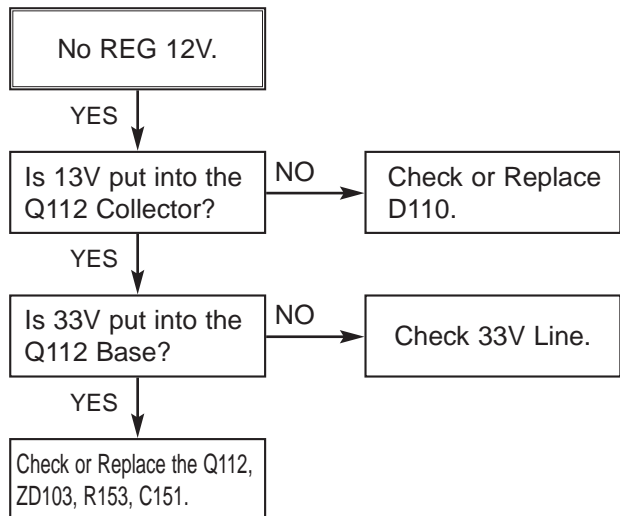

(8) No -29VA

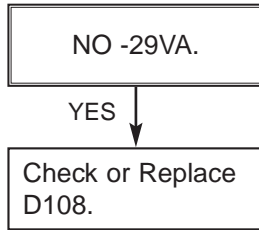

(9) No 8VA

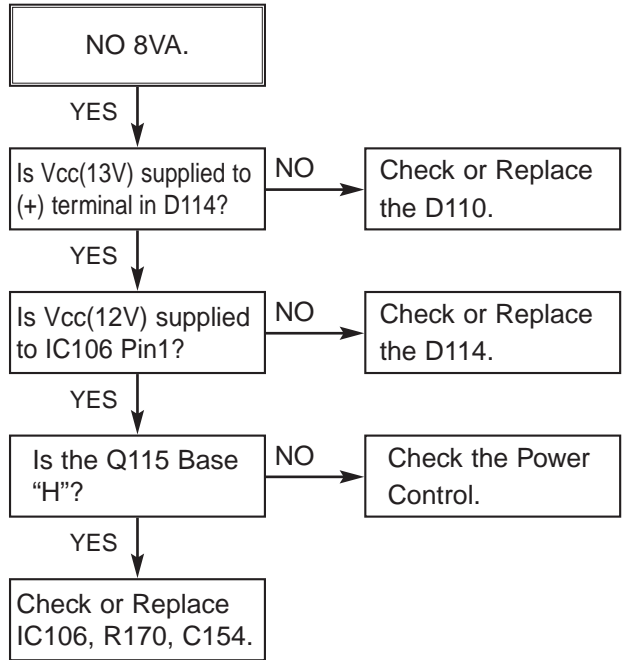

(10) No 3.3V

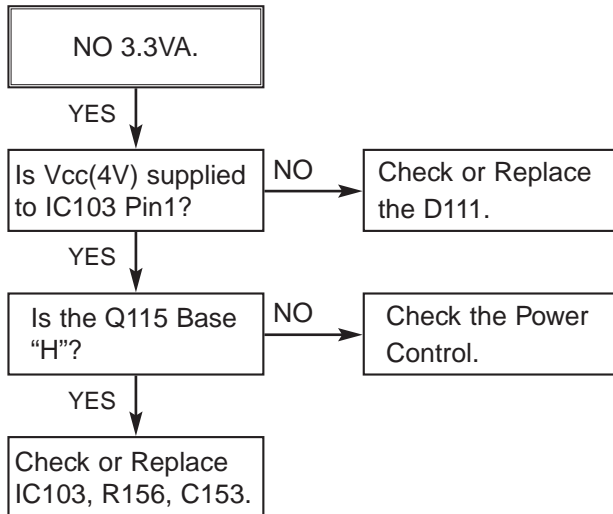

(11) No 2.5V

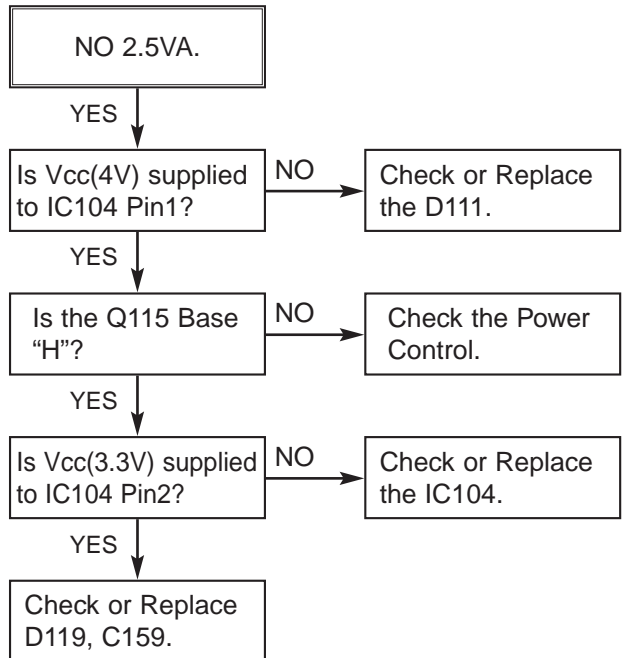

2. SYSTEM/KEY CIRCUIT

(1) AUTO STOP

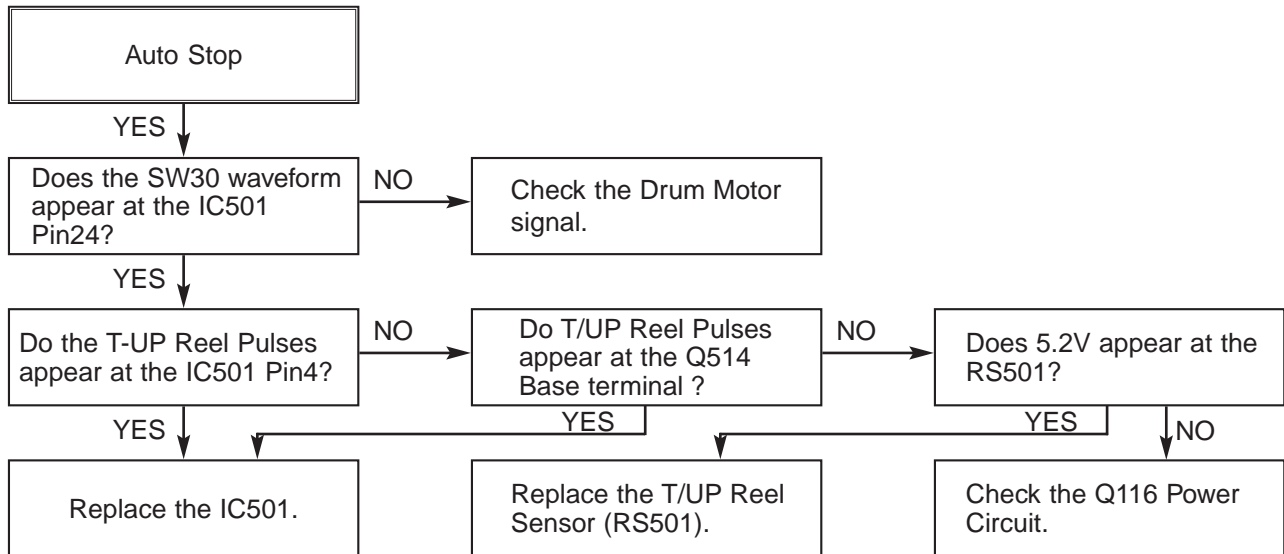

(2) The unstable loading of a Cassette tape

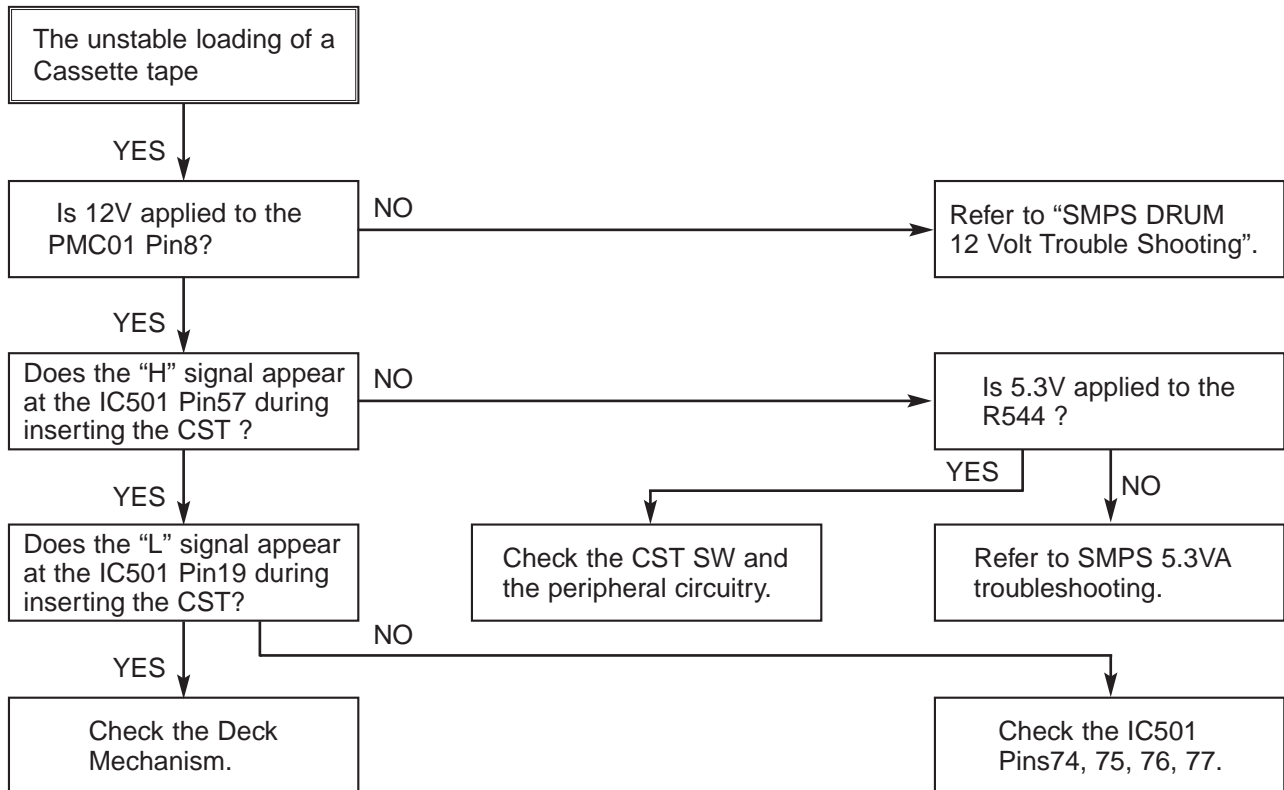

Caution : Auto stop can occur because Grease or Oil is dried up

3. SERVO CIRCUIT

(1) Unstable Video in PB MODE

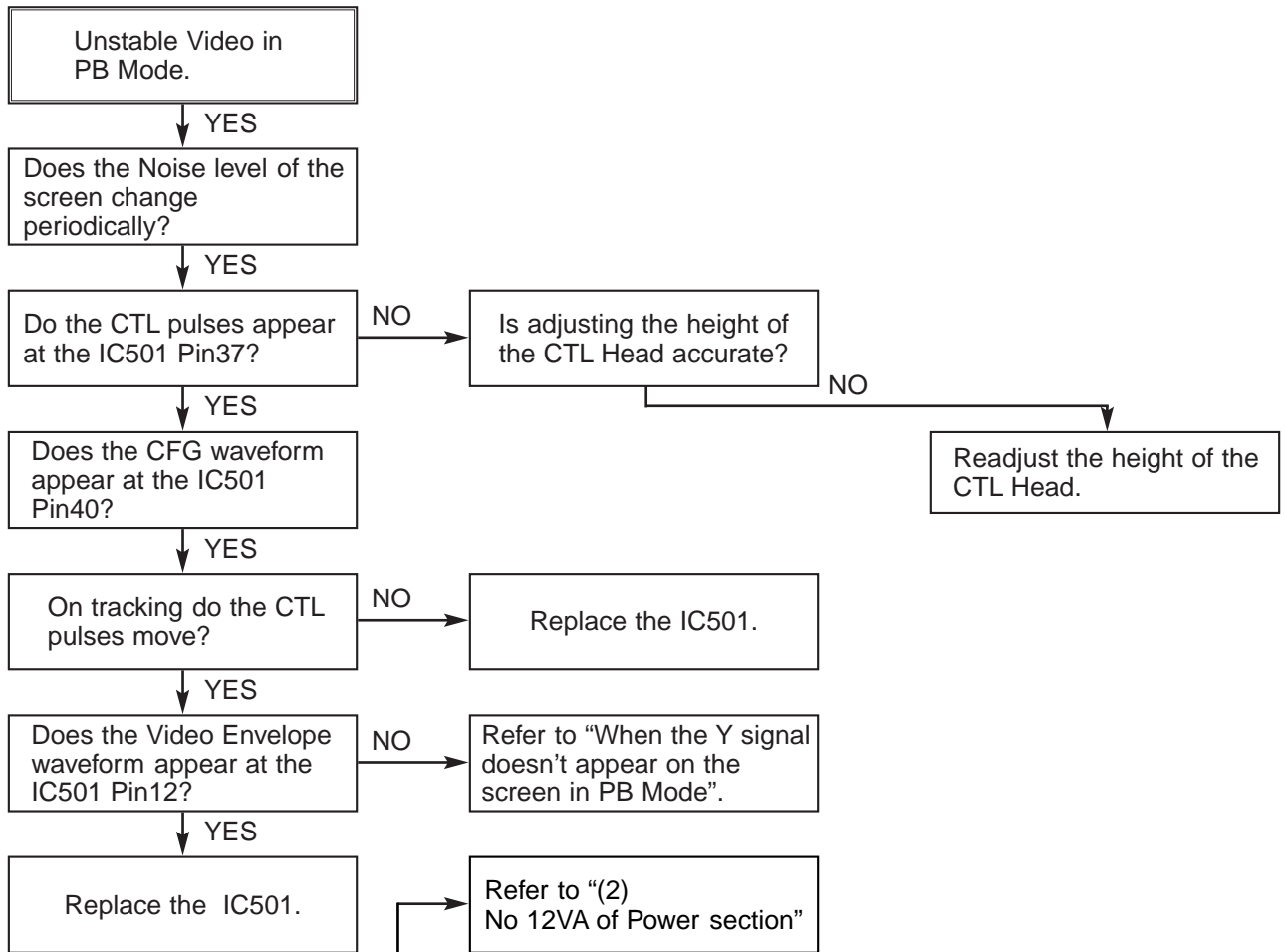

(2) When the Drum Motor doesn't run.

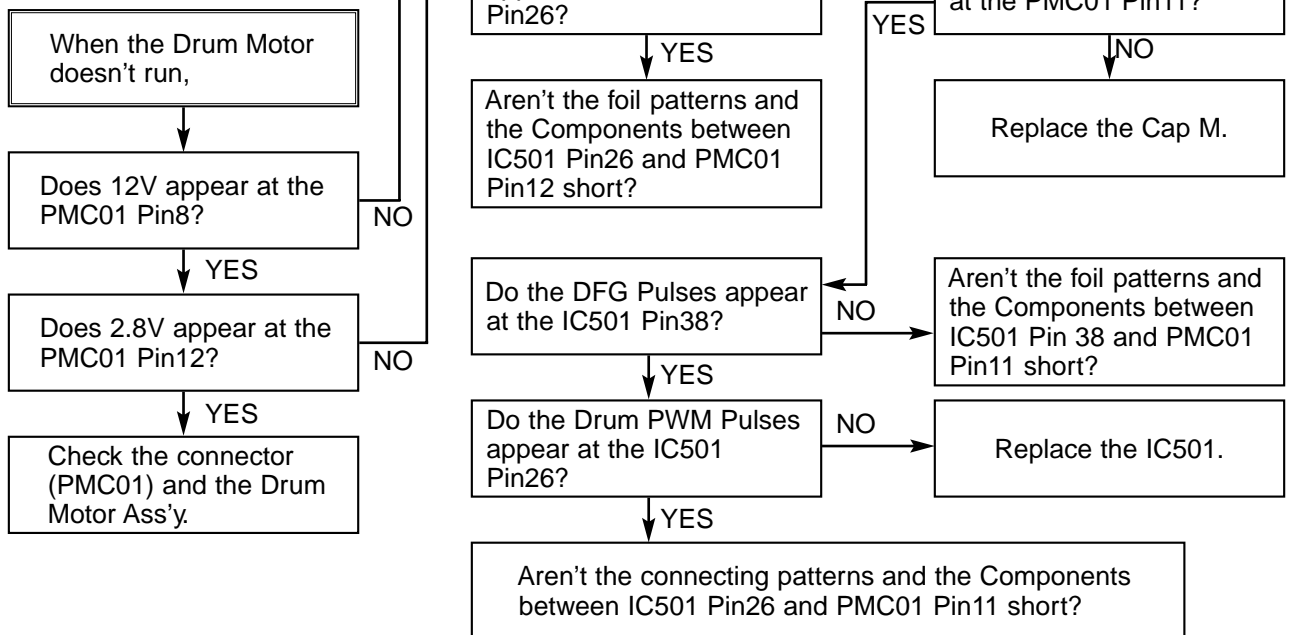

(3) When the Capstan Motor doesn't run,

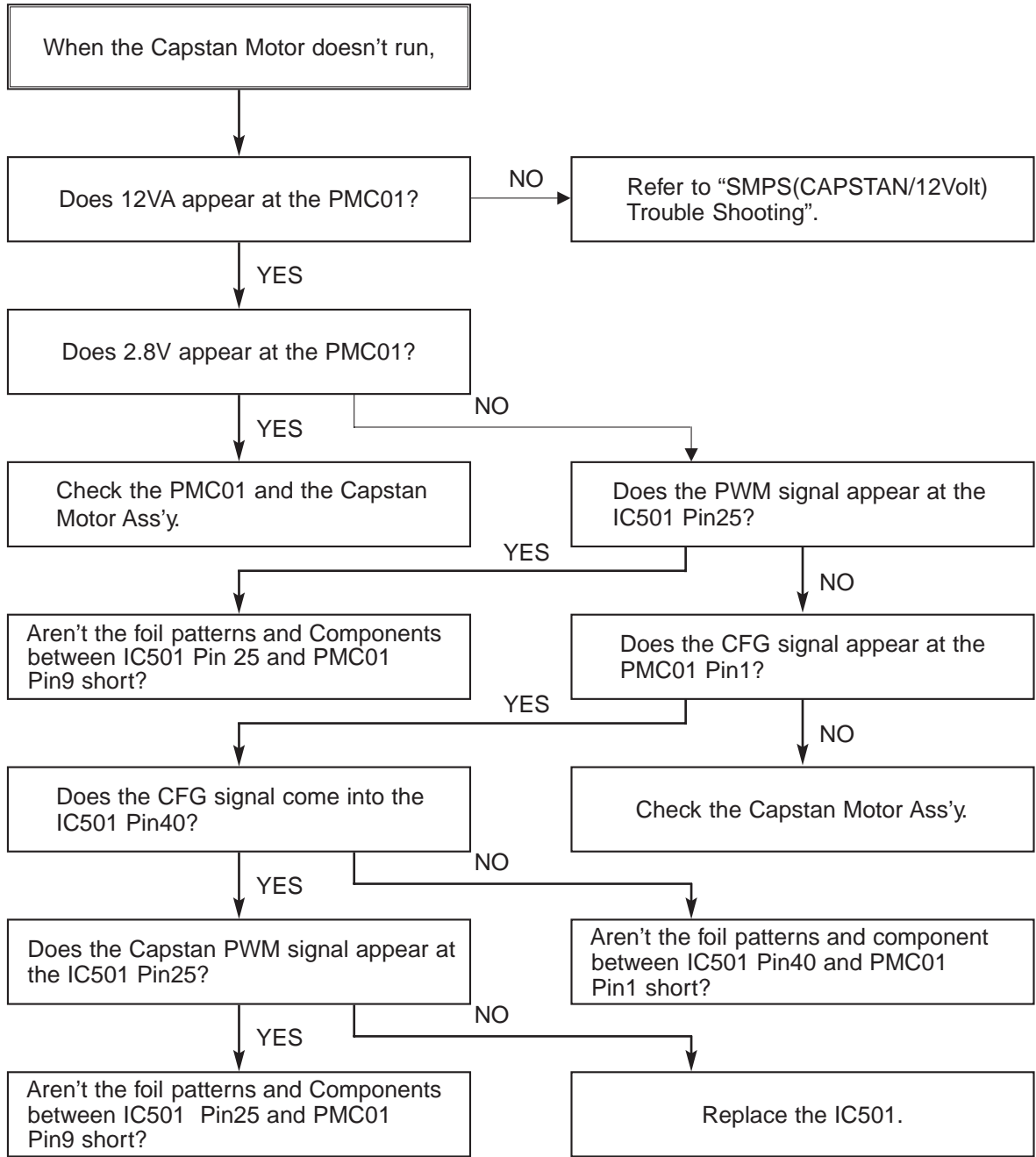

(3) KEY doesn't working

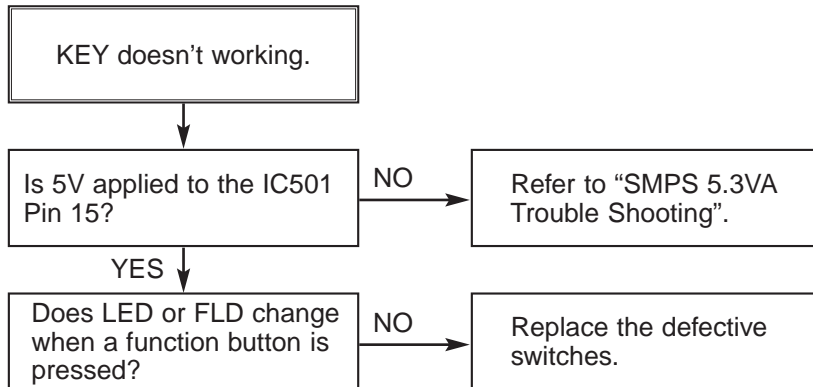

4. OSD CIRCUIT

(1) No OSD display.

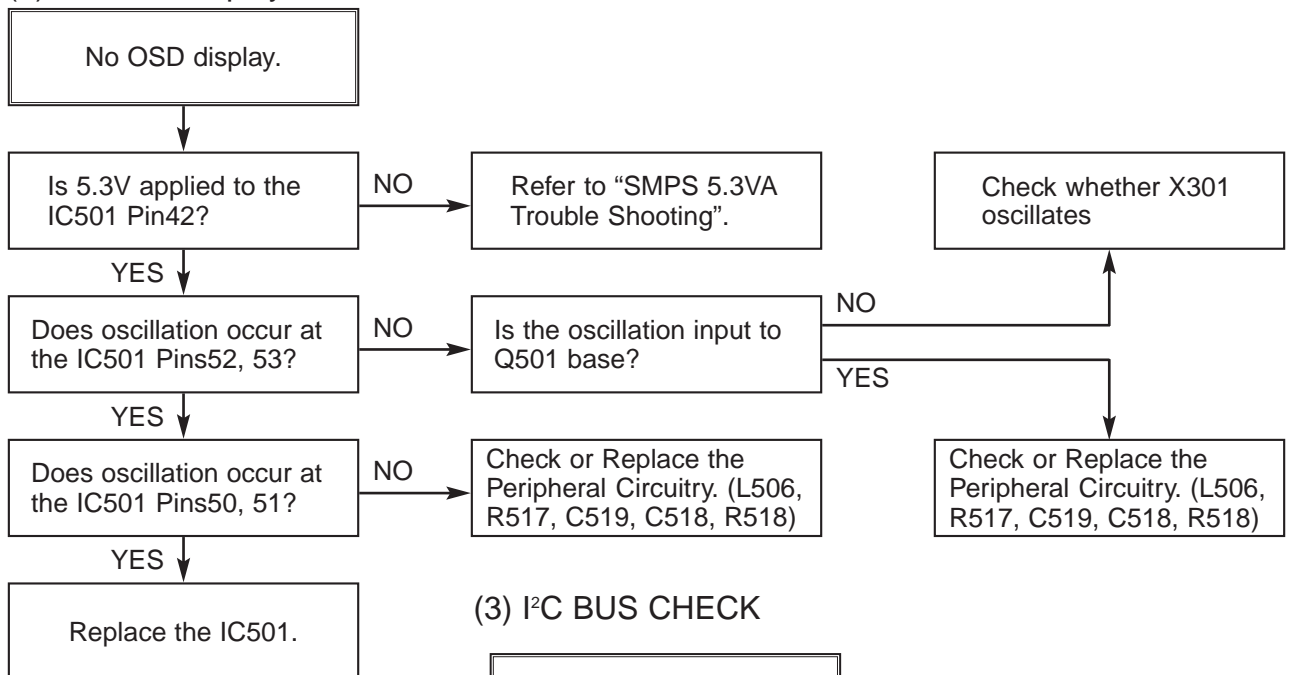

(2) No F.OSD display.

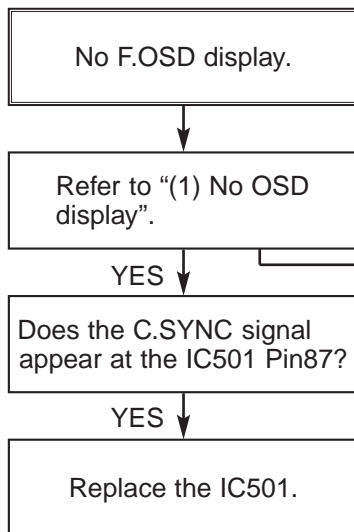

(3) I²C BUS CHECK

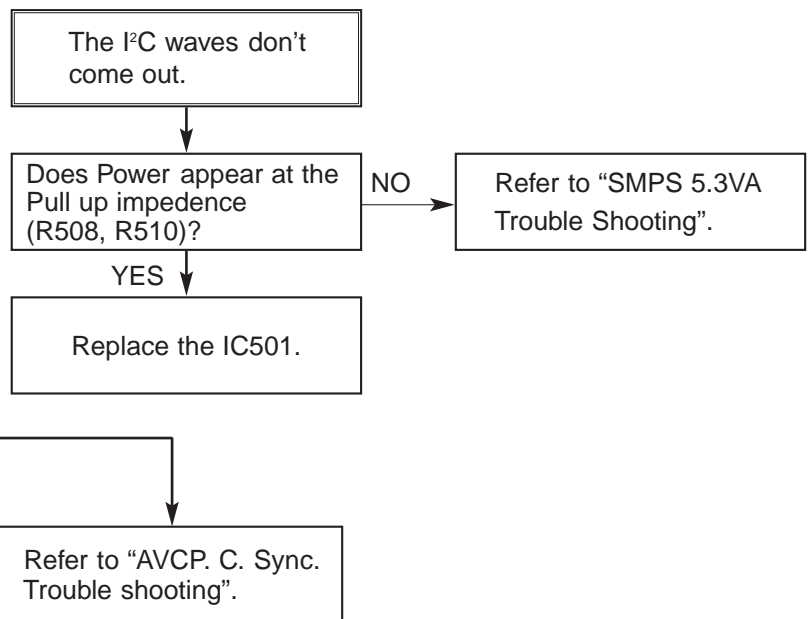

5. Y/C CIRCUIT

(1) No Video in EE Mode,

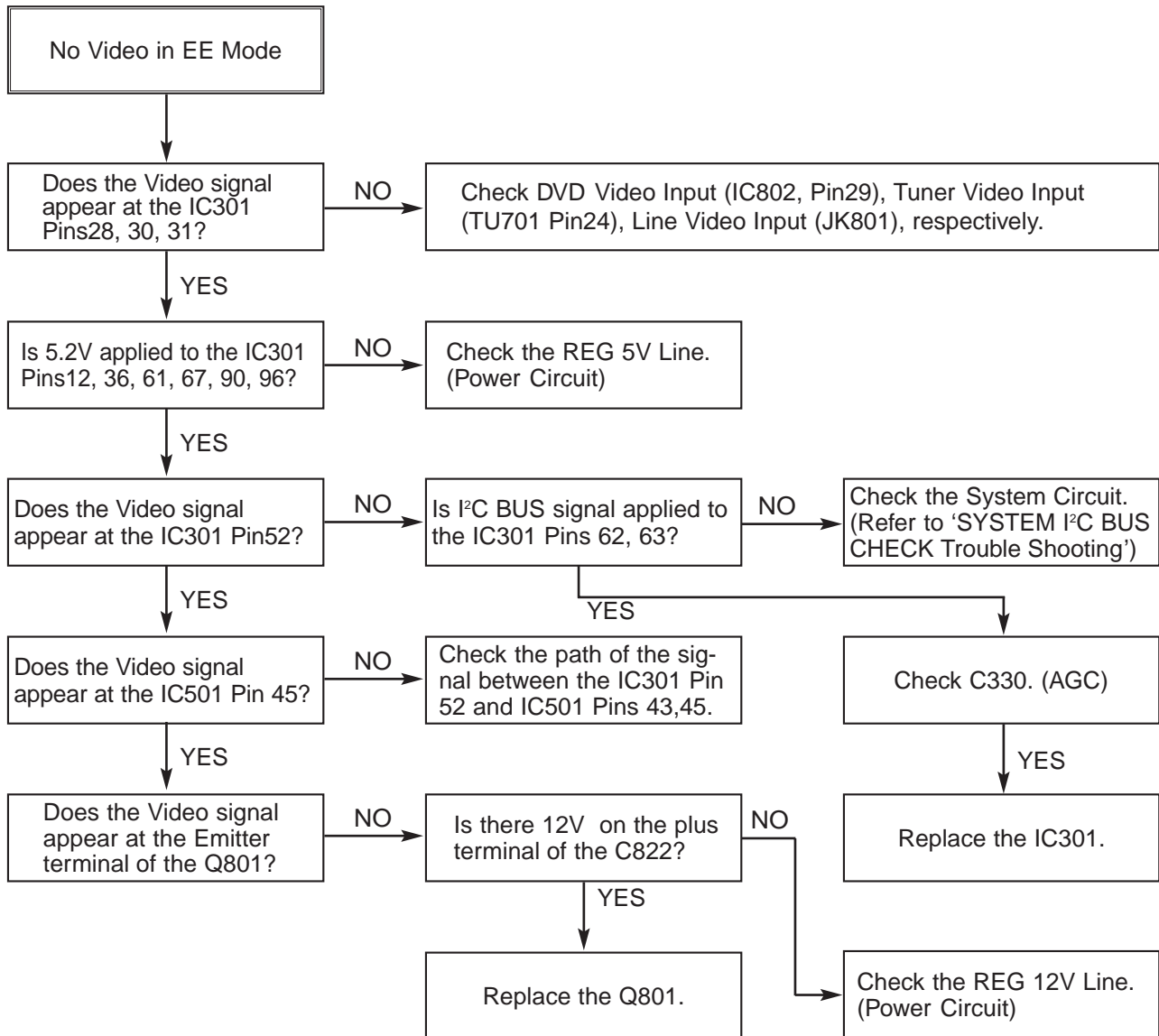

(2) When the Y(Luminance) signal doesn't appear on the screen in PB Mode,

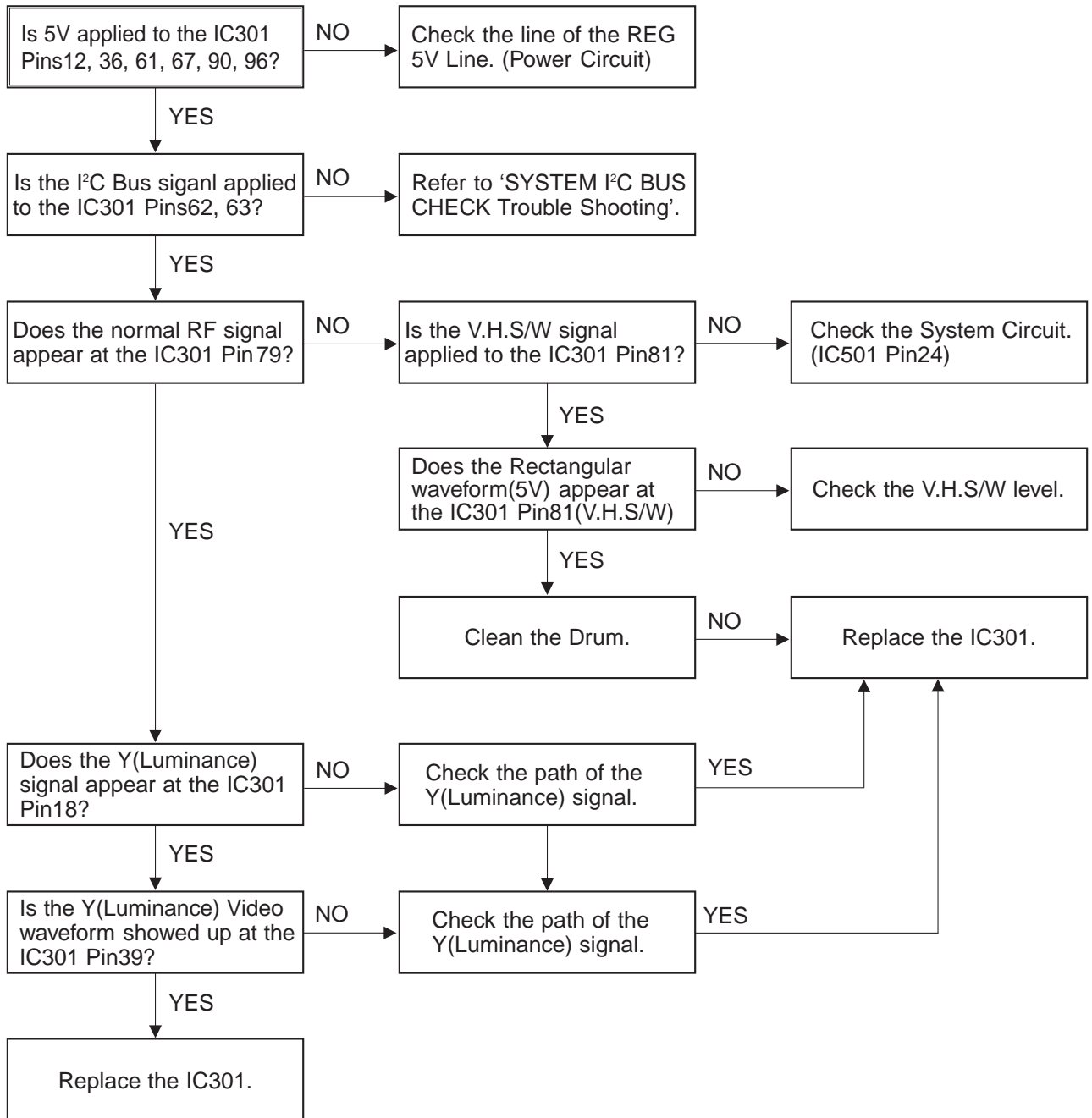

(3) When the C(Color) signal doesn't appear on the screen in PB Mode,

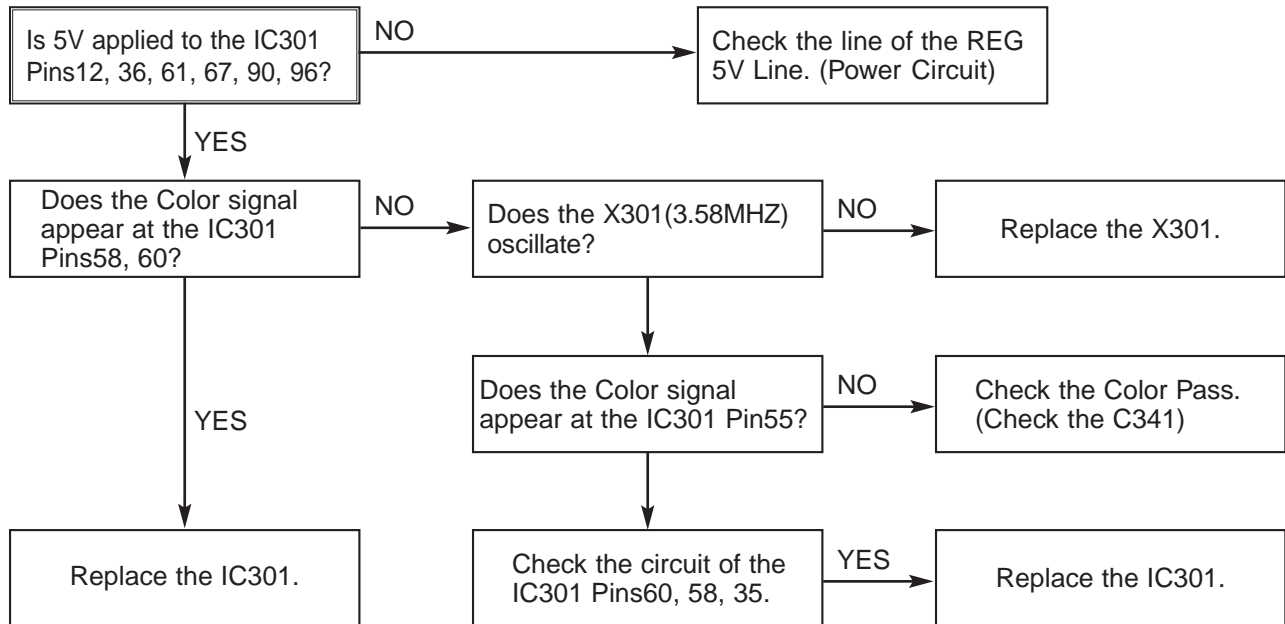

(4) When the Video signal doesn't appear on the screen in REC Mode,

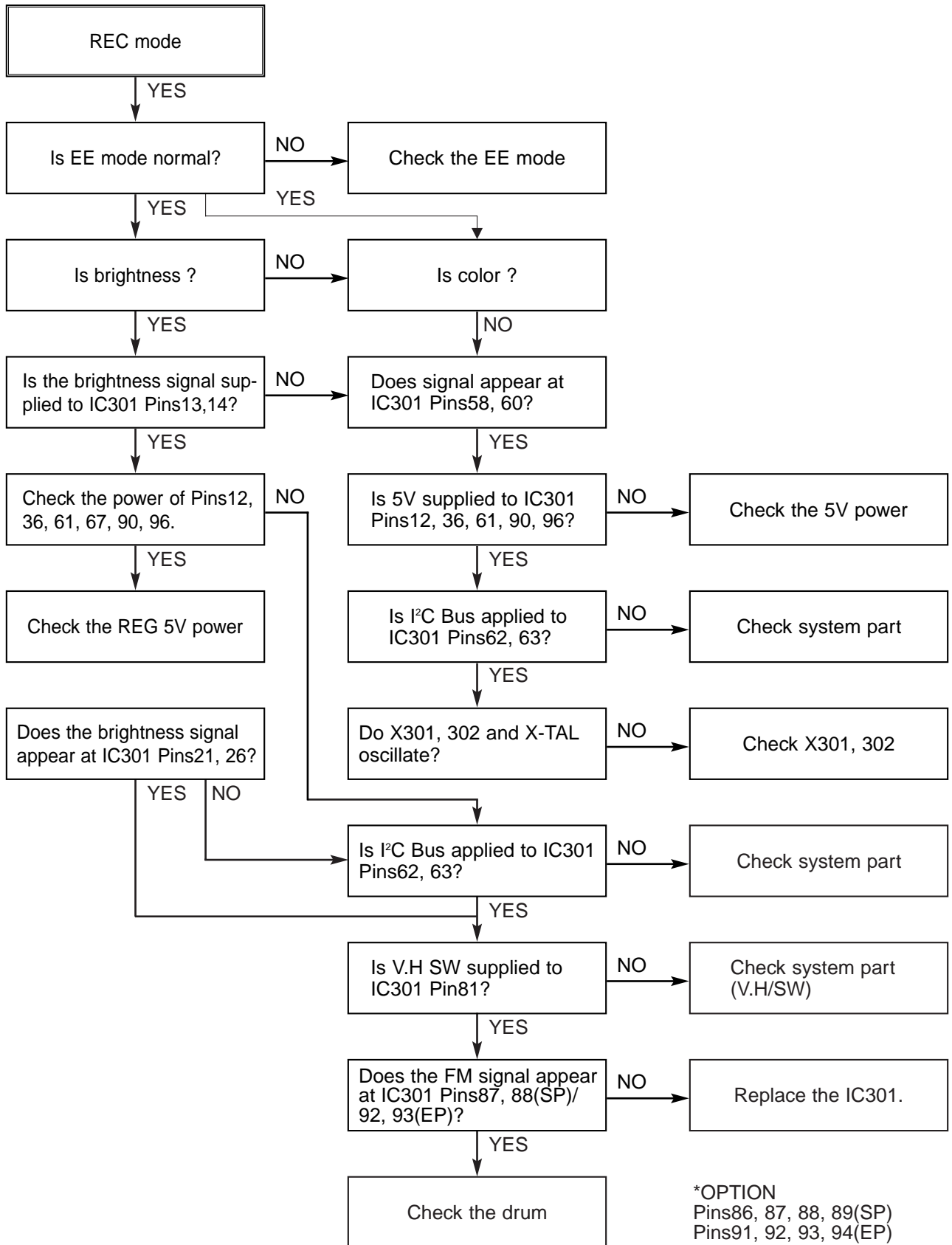

6. Hi-Fi CIRCUIT

(A) No Sound(EE Mode)

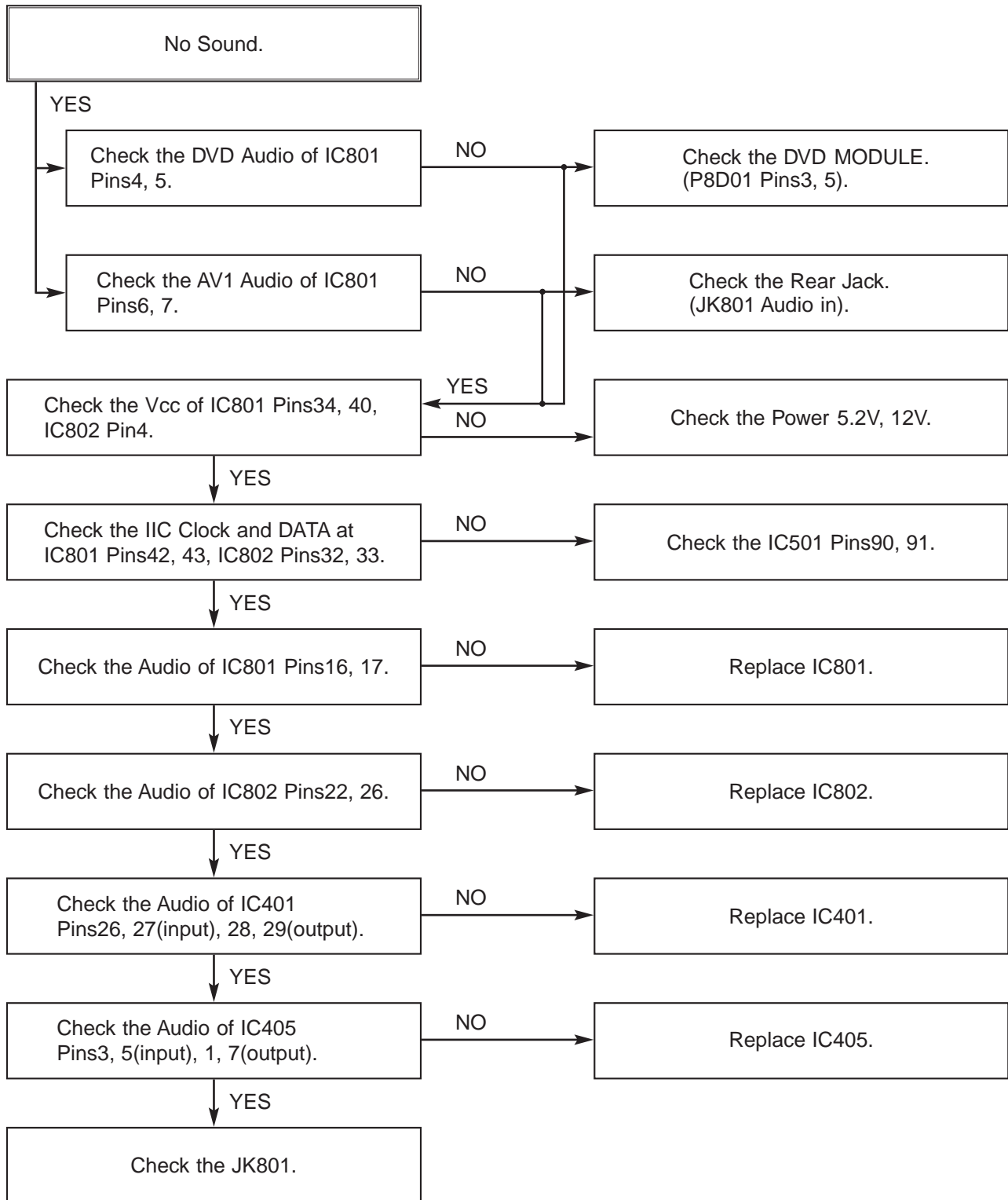

(B) Hi-Fi Playback

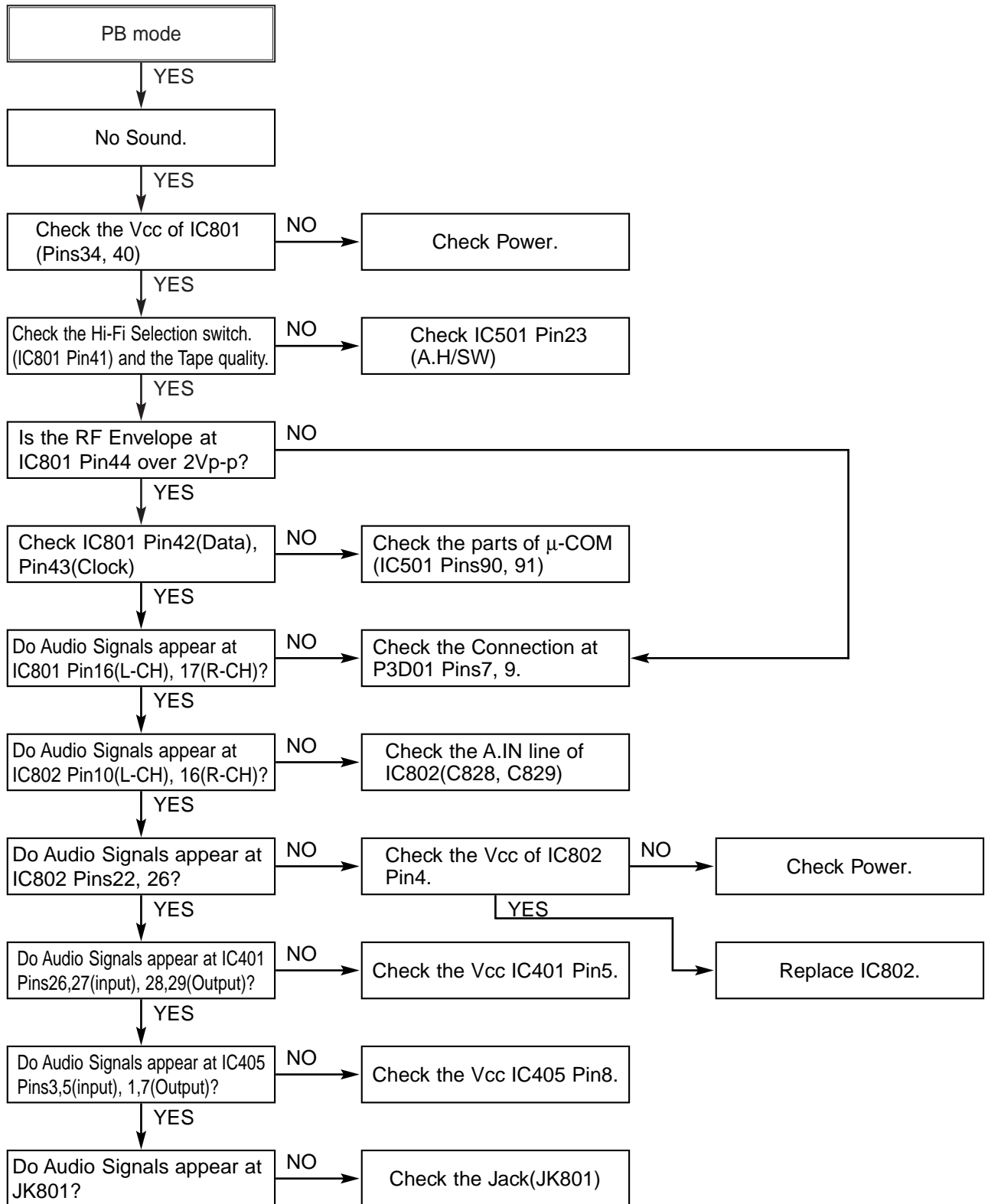

(C)

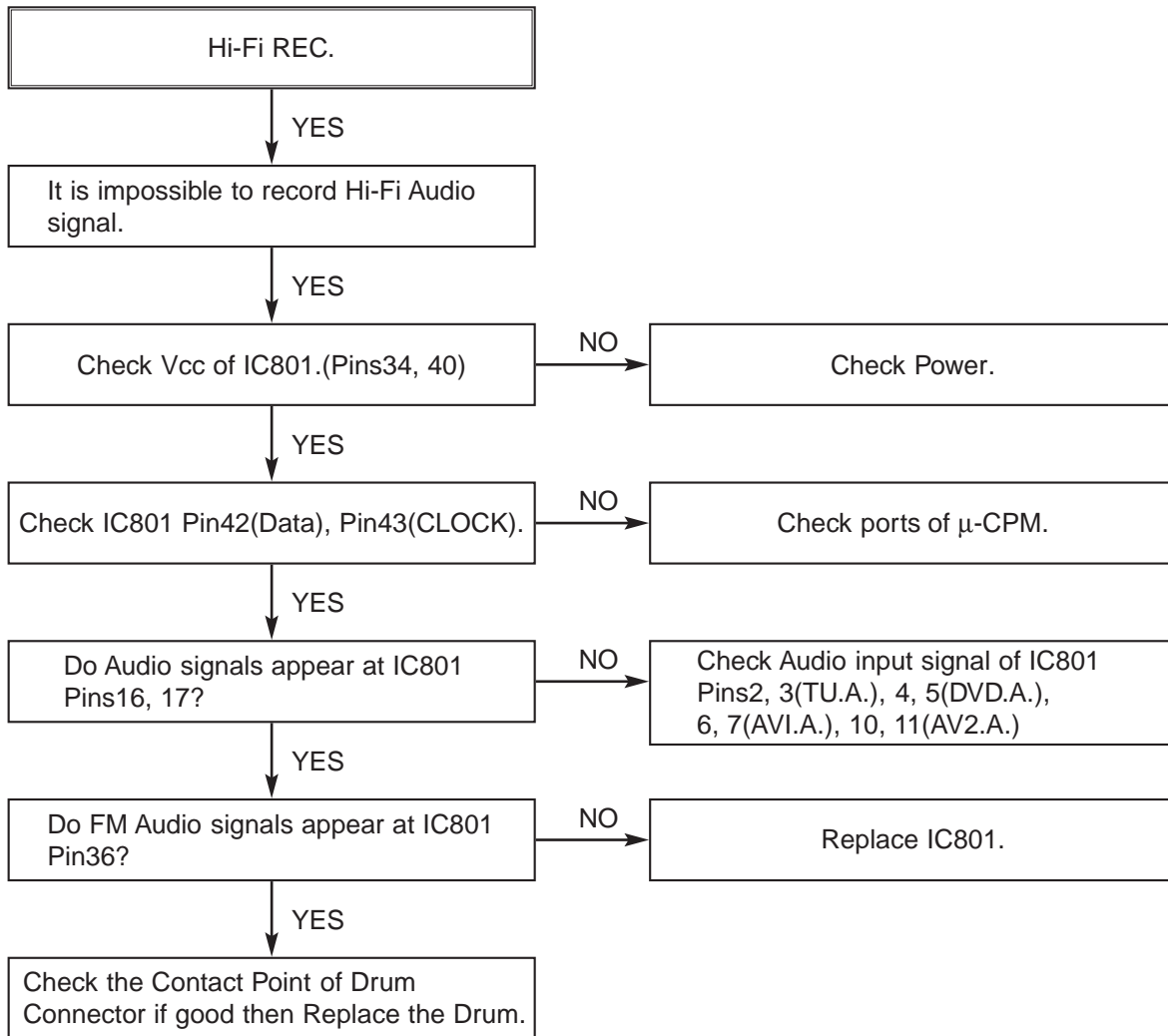

7. KARAOKE CIRCUIT

A.

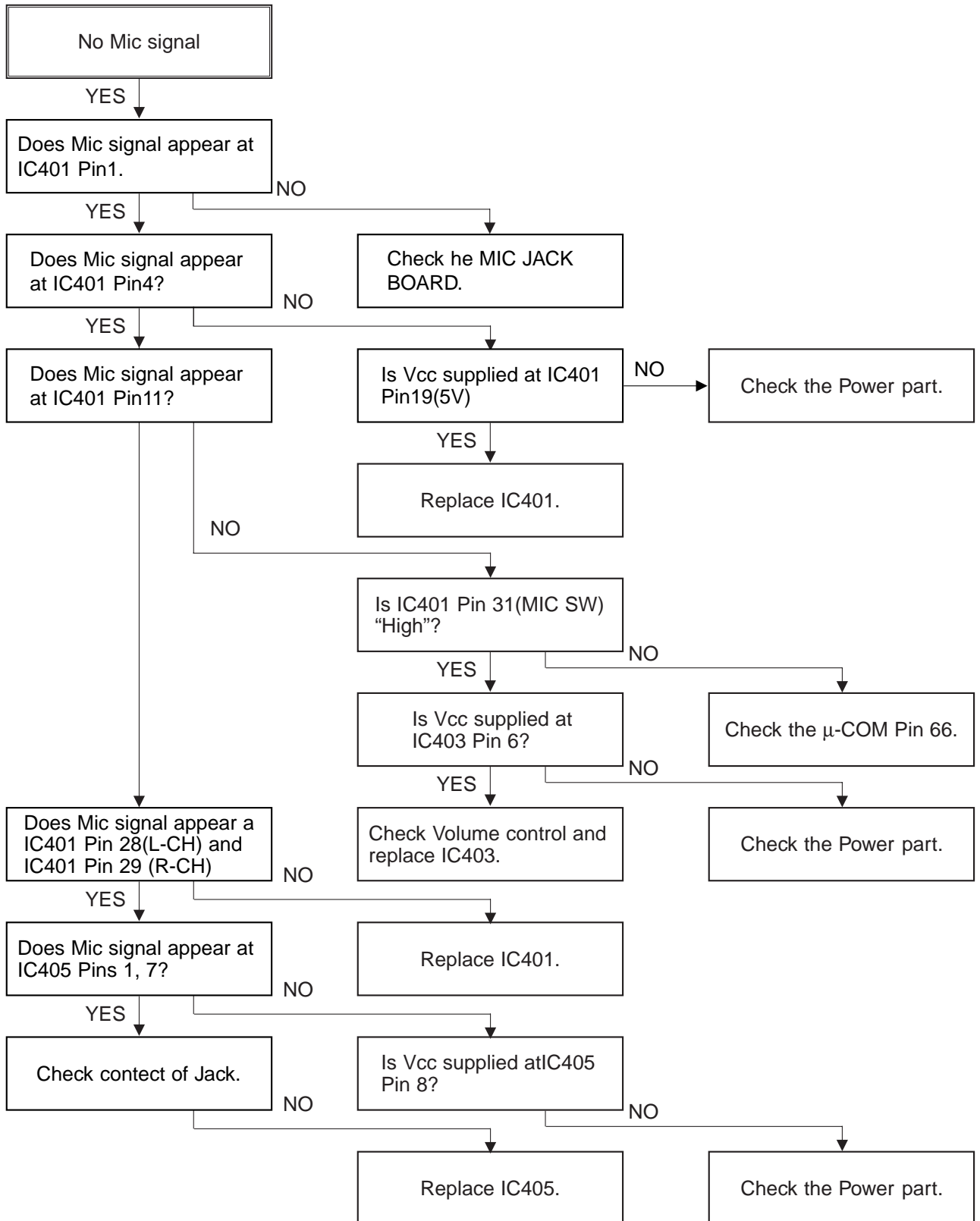

B.

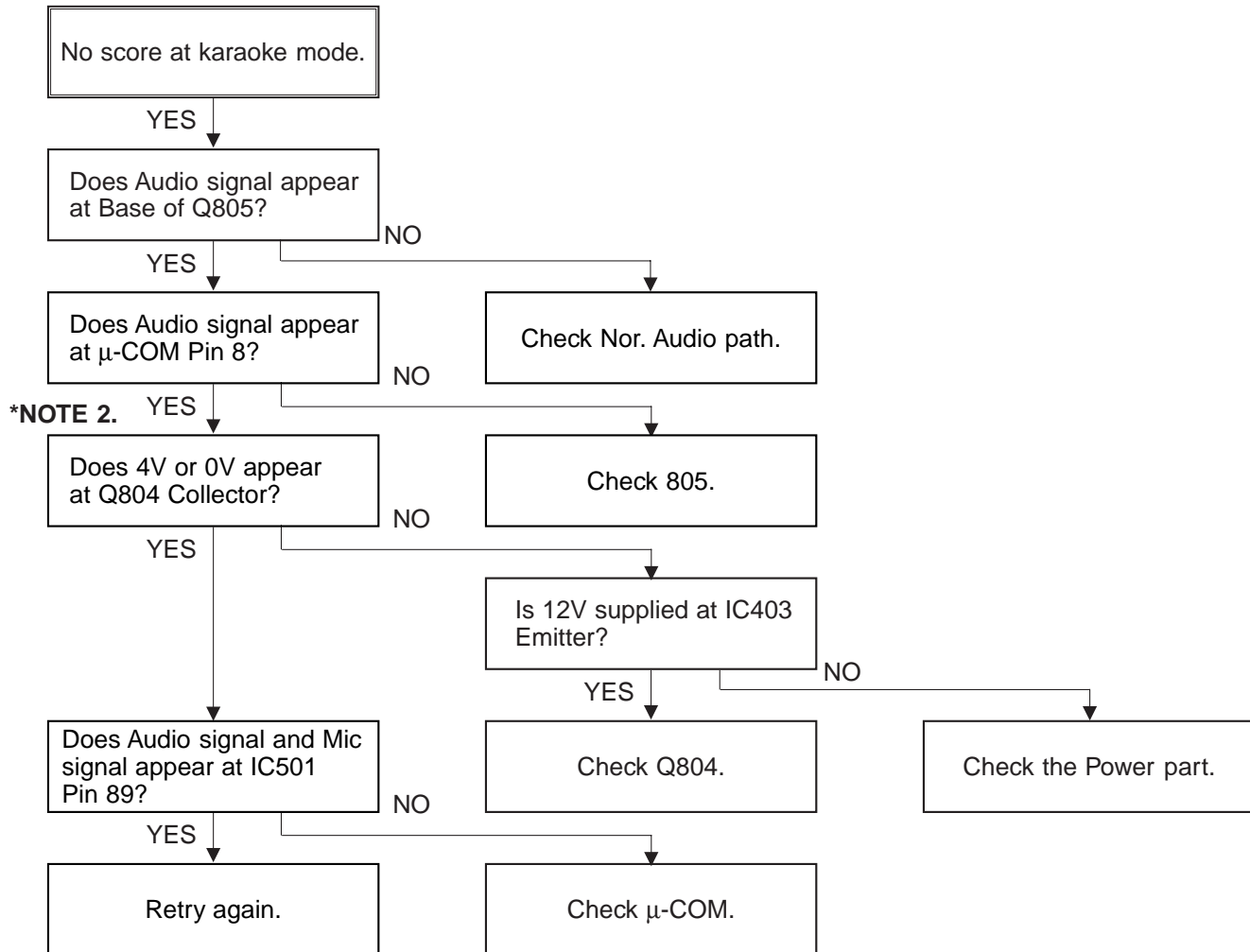

***NOTE 2.**

In general karaoke tape, between song, it has a blank period more than 3sec. This system detects this blank period Noise Level. But when this period level is high or period ltime is short, this system has not blank time. In case of, this system doesn't display the score.

DVD PART

ELECTRICAL TROUBLESHOOTING GUIDE

1. μ -COM Circuit

A. No Power

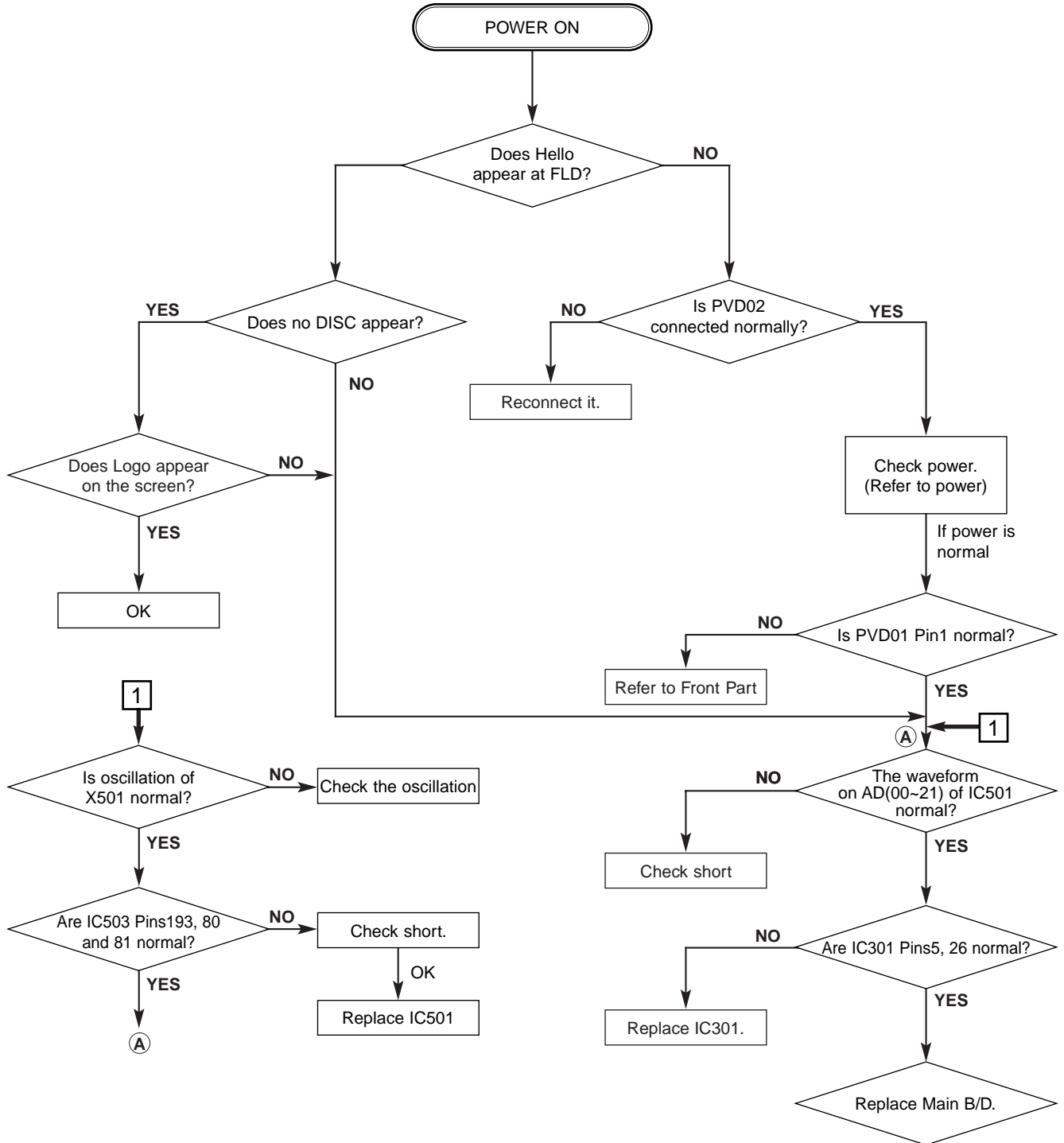

B. Audio abnormal

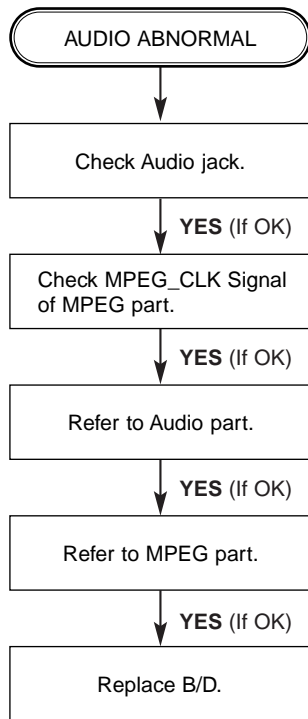

C. Video abnormal

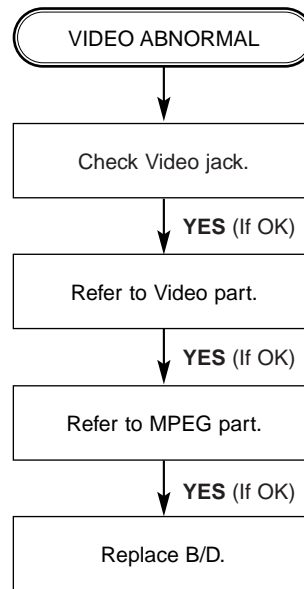

D. Open/Close abnormal

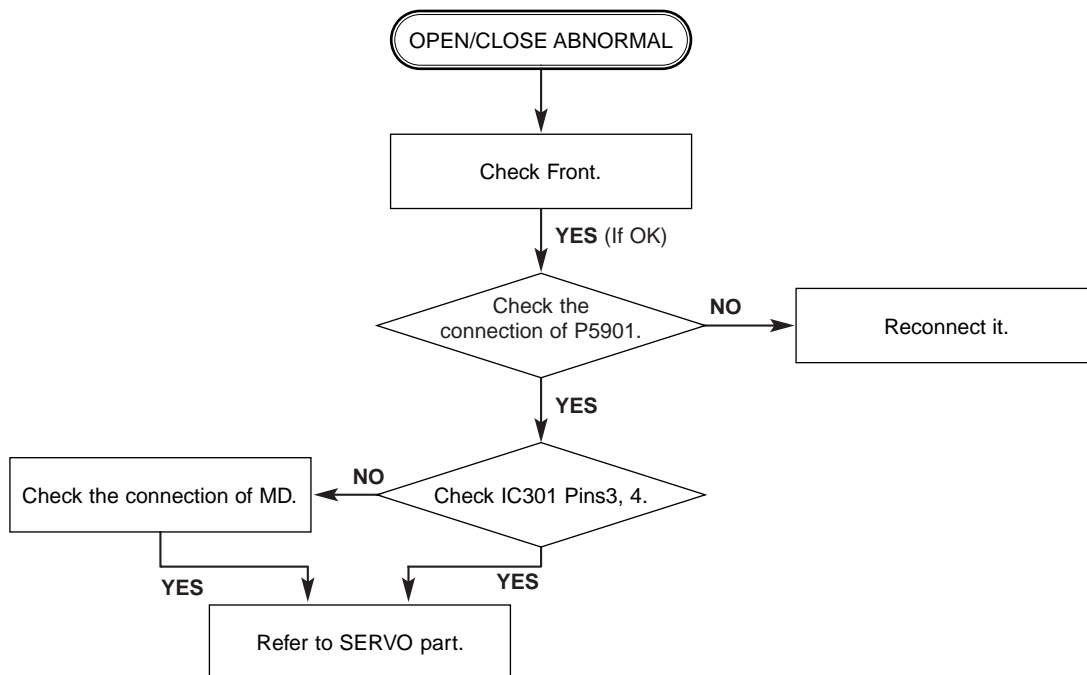

E. Picture abnormal

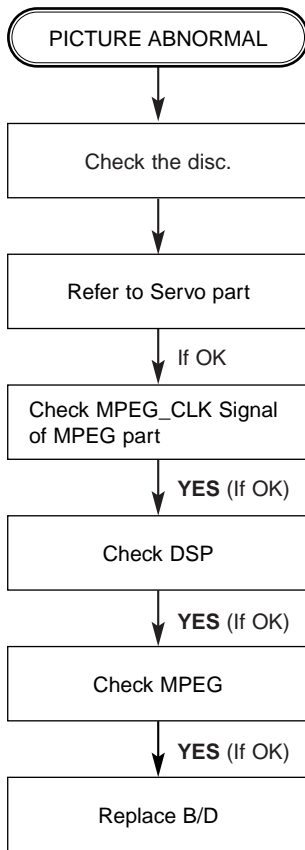

F. Disc Error

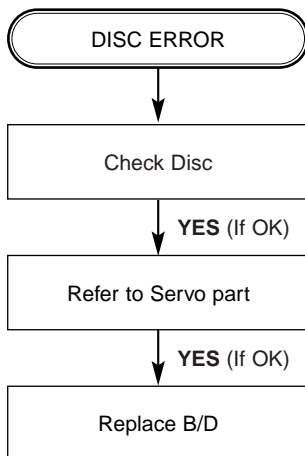

2. MPEG Circuit

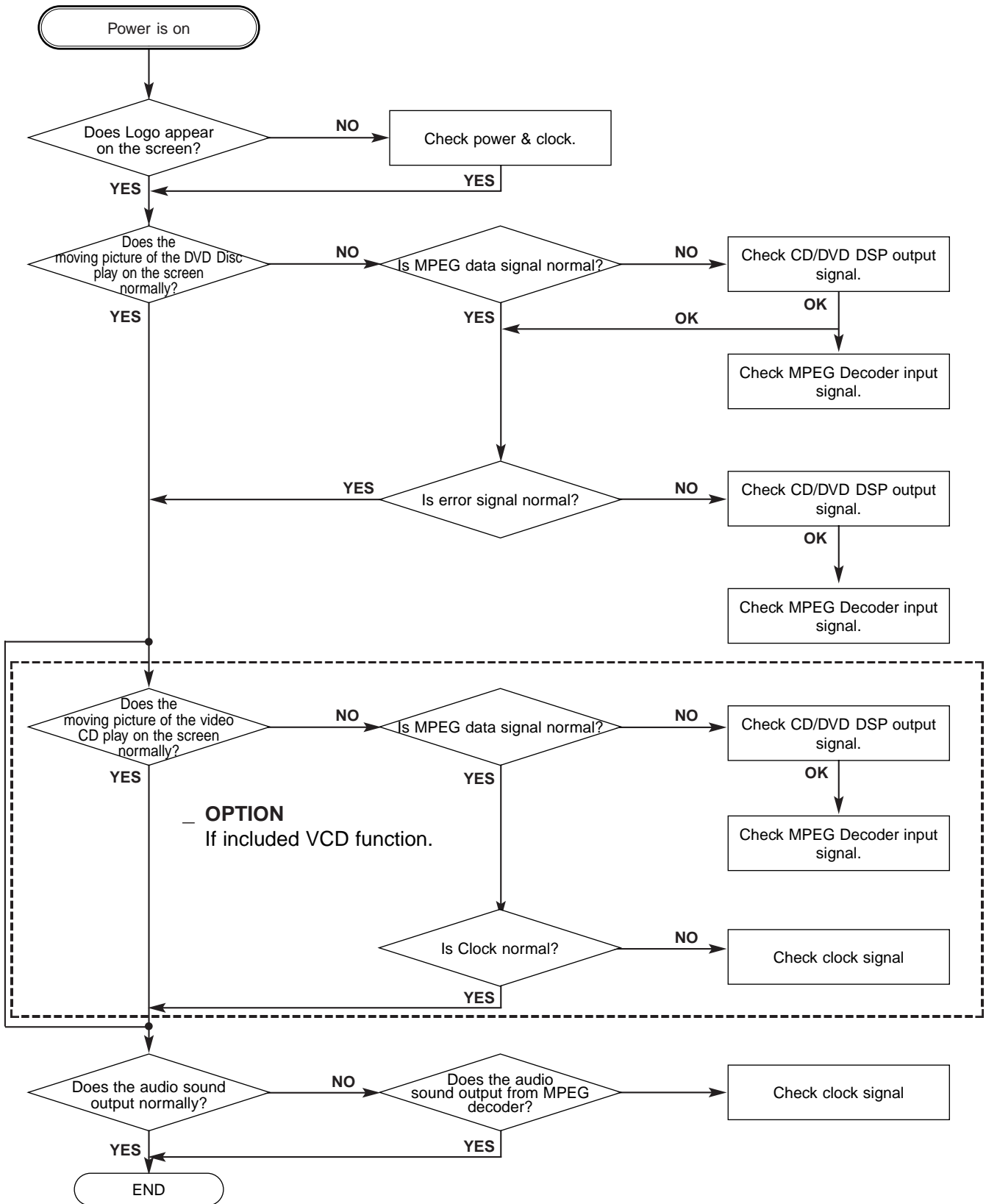

3. RF/Servo Circuit A.

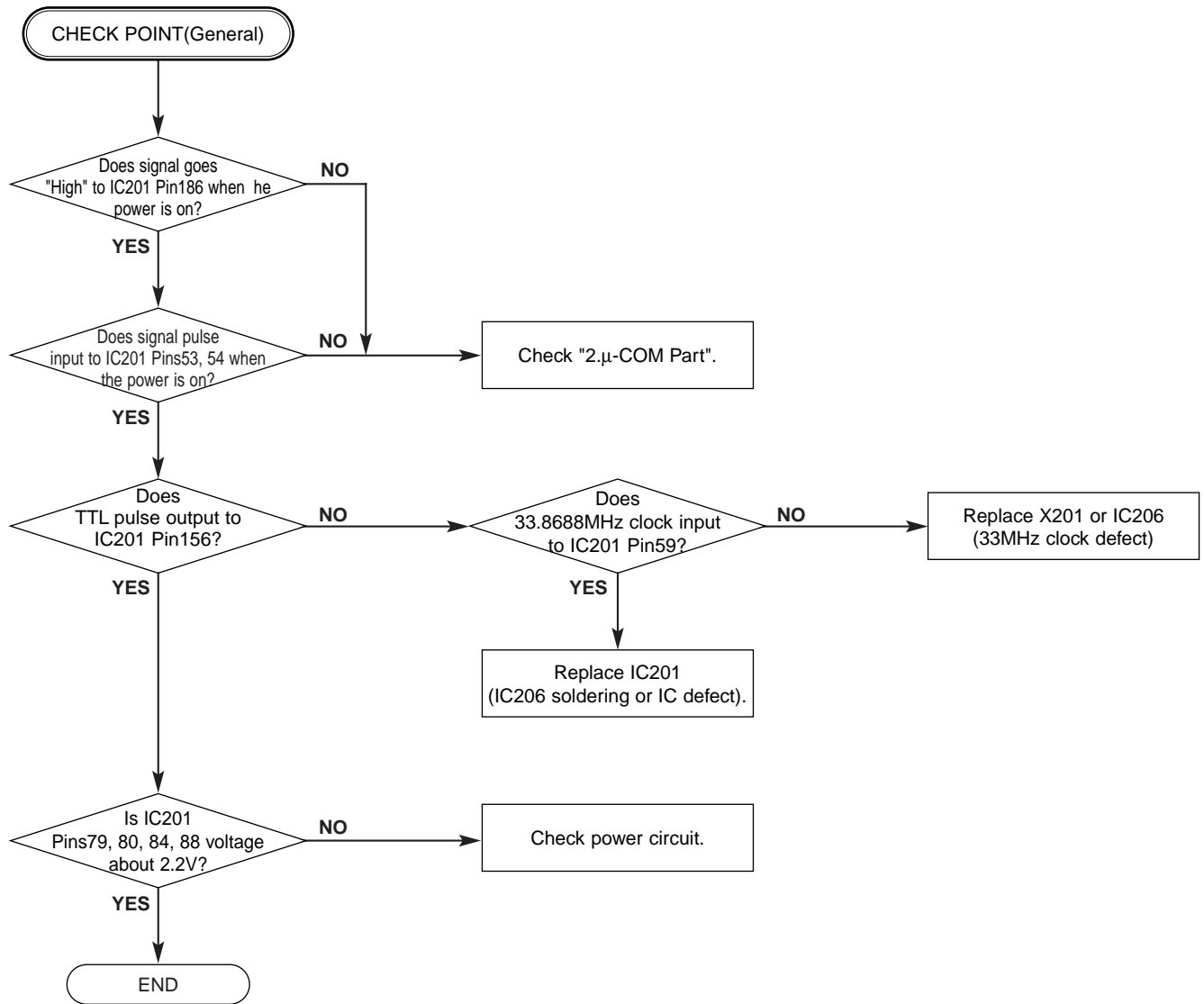

B.

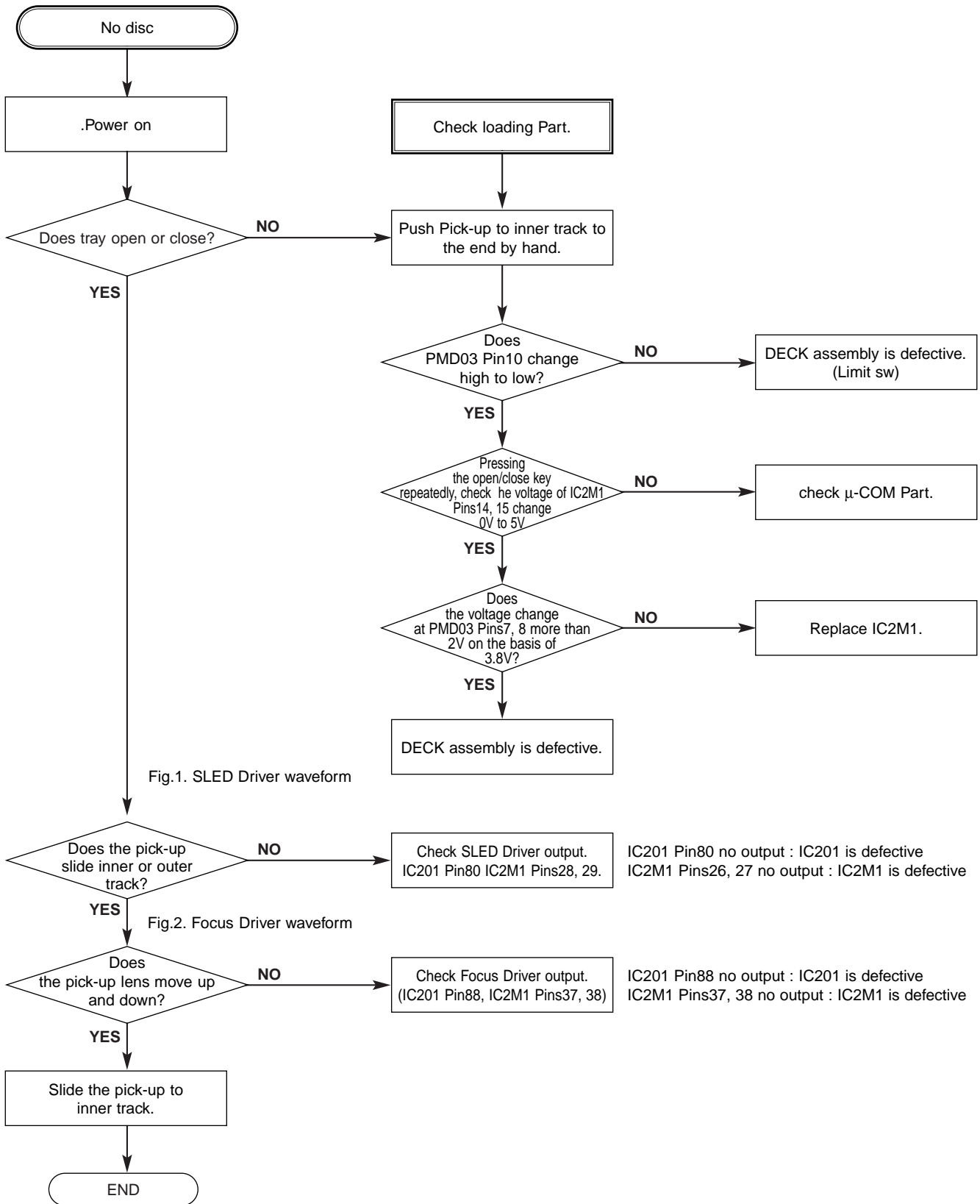

C.

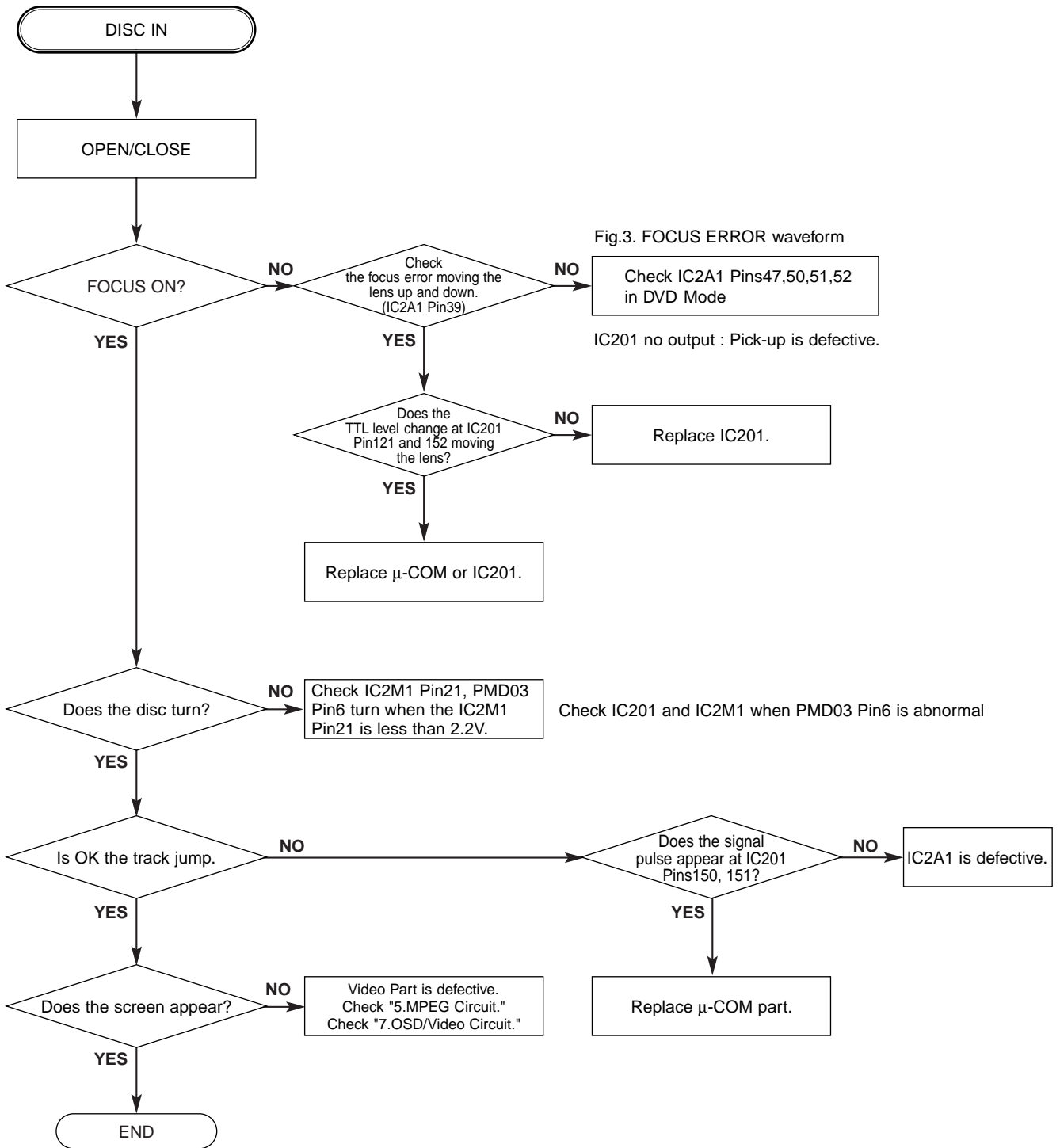

Fig.3. FOCUS ERROR waveform

Check IC2A1 Pins47,50,51,52 in DVD Mode

IC201 no output : Pick-up is defective.

Check IC201 and IC2M1 when PMD03 Pin6 is abnormal

D.

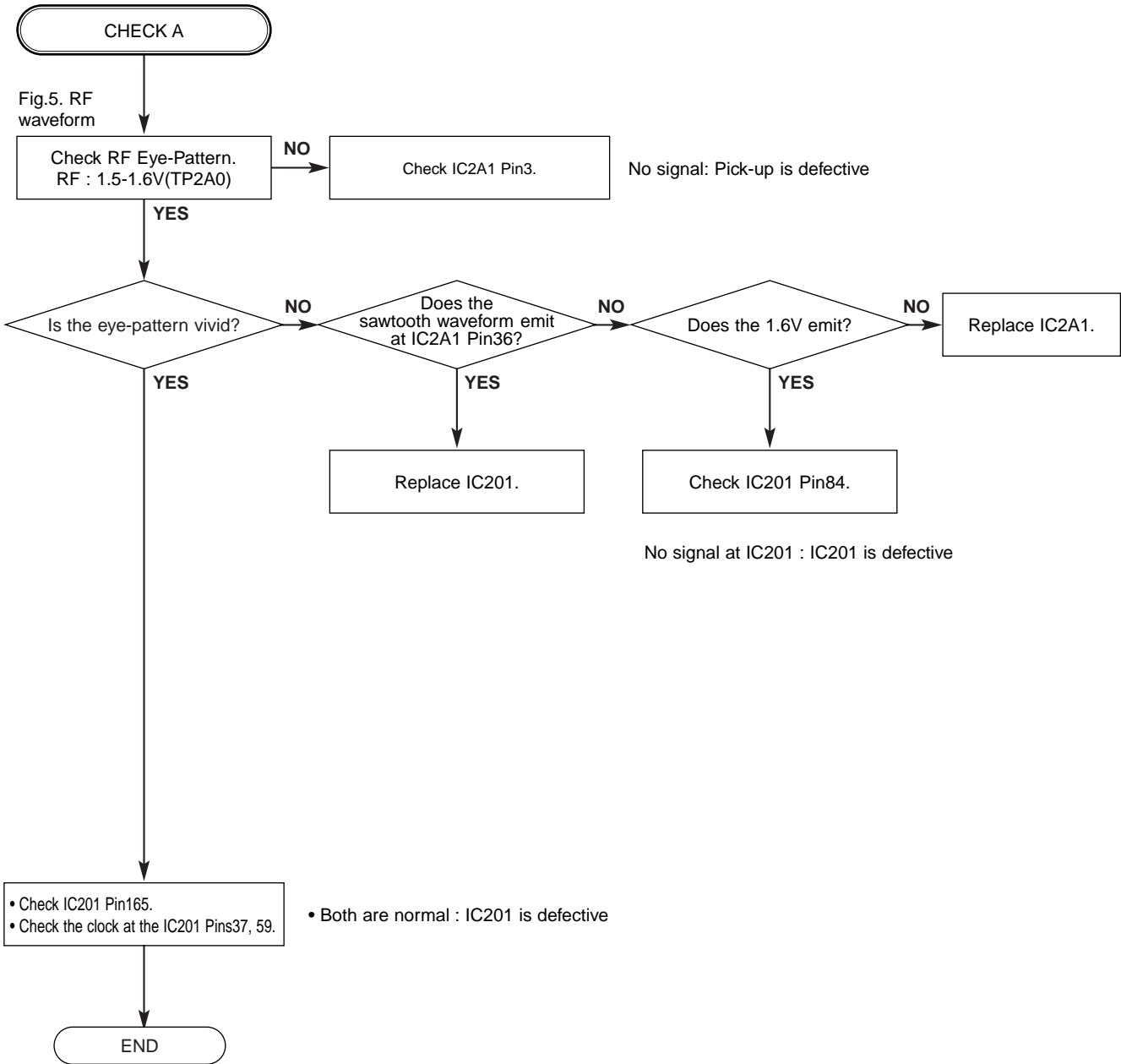

SECTION 4 MECHANISM OF VCR PART

CONTENTS

DECK MECHANISM PARTS LOCATIONS

- Top View4-1
- Bottom View4-1

DECK MECHANISM DISASSEMBLY

1. Drum Assembly4-2
2. Plate Top4-4
3. Holder Assembly CST4-4
4. Opener Door4-4
5. Bracket Assembly L/D Motor.....4-4
6. Gear Assembly Rack F/L4-4
7. Arm Assembly F/L.....4-4
8. Lever Assembly S/W.....4-4
9. Arm Assembly Cleaner.....4-5
10. Head F/E4-5
11. Base Assembly A/C Head4-5
12. Brake Assembly T4-6
13. Brake Assembly RS4-6
14. Arm Assembly Tension.....4-6
15. Reel S / Reel T.....4-6
16. Base Assembly P44-7
17. Opener Lid4-7
18. Arm Assembly Pinch4-7
19. Lever T/up / Arm T/up4-7
20. Belt Capstan/Motor Capstan.....4-8
21. Lever F/R4-8
22. Clutch Assembly D354-8
23. Brake Assembly Capstan4-8
24. Gear Drive/Gear Cam4-9
25. Gear Sector4-9
26. Plate Slider4-9
27. Lever Tension4-9
28. Lever Spring.....4-9
29. Gear Assembly P2/
Gear Assembly P34-10
30. Base Assembly P2/
Base Assembly P34-10
31. Base Loading4-11
32. Base Tension4-11
33. Arm Assembly Idler4-11

DECK MECHANISM ADJUSTMENT

- Tools and Fixtures for Service4-12
1. Mechanism Alignment Position Check....4-13
 2. Preparation for Adjustment.....4-14
 3. Checking Torque4-14
 4. Guide Roller Height Adjustment.....4-15
 - 4-1. Preliminary Adjustment4-15
 - 4-2. Precise Adjustment4-15
 5. Audio/Control (A/C) Head Adjustment4-16
 - 5-1. Preliminary Adjustment4-16
 - 5-2. Confirmation of Tape Path between
Pinch Roller and Take-up Guide.....4-17
 - 5-3. Precise Adjustment(Azimuth Adjustment)
.....4-17
 6. X-Value Adjustment4-17
 7. Adjustment after Replacing Drum Assembly
(Video Heads)4-18
 8. Check the Tape Travel after Reassembling
Deck Mechanism.....4-18
 - 8-1. Checking Audio and RF Locking Time
during Playback after CUE or REV
.....4-18
 - 8-2. Checking for Tape Curling or
Jamming4-18

MAINTENANCE/INSPECTION PROCEDURE

1. Check before starting Repairs4-19
2. Required Maintenance4-20
3. Scheduled Maintenance.....4-20
4. Supplies Required for Inspection and
Maintenance.....4-20
5. Maintenance Procedure4-20
 - 5-1. Cleaning4-20
 - 5-2. Greasing4-21

MECHANISM TROUBLESHOOTING GUIDE

1. Deck Mechanism.....4-23
2. Front Loading Mechanism.....4-26

EXPLODED VIEWS

1. Front Loading Mechanism Section4-28
 2. Moving Mechanism Section (1).....4-29
 3. Moving Mechanism Section (2).....4-30
-

DECK MECHANISM PARTS LOCATIONS

• Top View

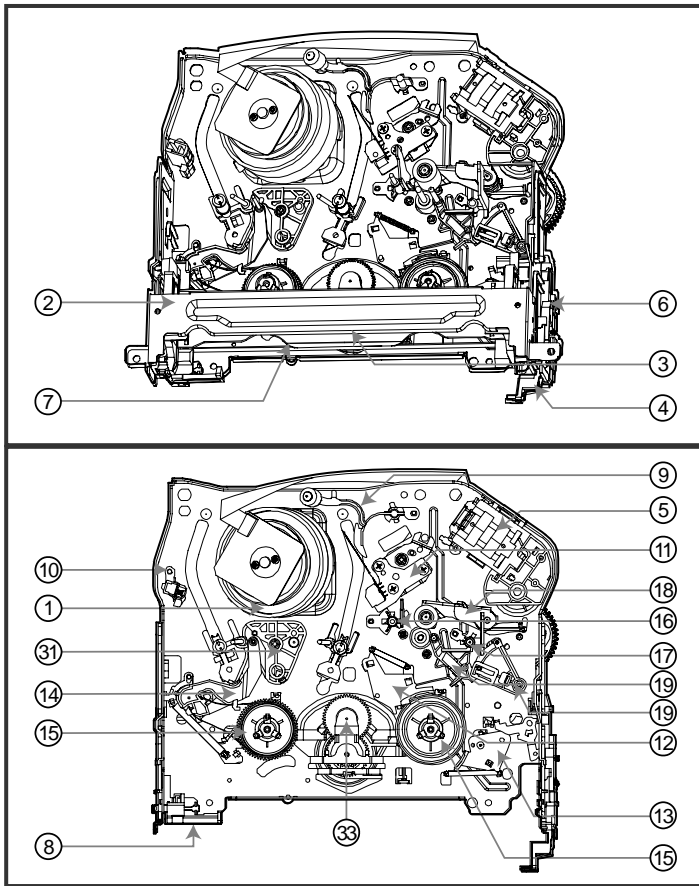

• Bottom View

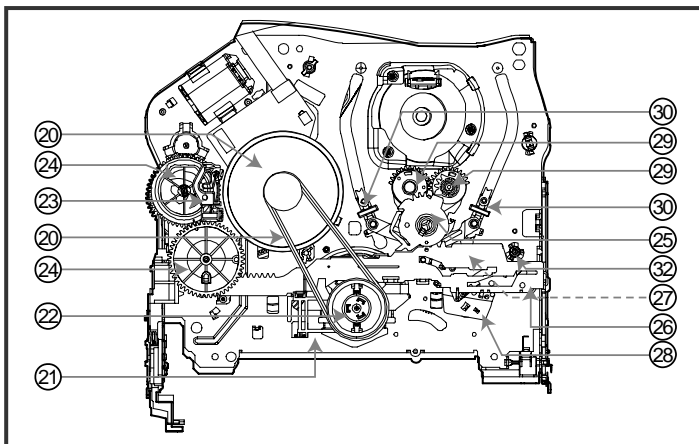

Starting No.	Procedure	Part	Fixing Type	Figure	View
1		Drum Assembly	3 Screw	A-1	T
2		Plate Top	2 Hook	A-2	T
2		Holder Assembly CST	Chassis Hole	A-2	T
2		Opener Door	Chassis Hole	A-2	T
5		Bracket Assembly L/D Motor	3 Hook	A-2	T
2,3,4		Gear Assembly Rack F/L	1 Hook, Chassis Hole	A-2	T
2,3,4,6		Arm Assembly F/L	Chassis Hole	A-2	T
8		Lever Assembly S/W	1 Hook	A-2	T
9		Arm Assembly Cleaner	Chassis Embossing	A-3	T
10		Head F/E	Chassis Embossing	A-3	T
11		Base Assembly A/C Head	1 Screw	A-3	T
2,3		Brake Assembly T	1 Hook	A-4	T
2,3		Brake Assembly RS	1 Hook	A-4	T
2,3		Arm Assembly Tension	2 Hook	A-4	T
2,3,12,13, 14		Reel S/Reel T		A-4	T
16		Base Assembly P4	Chassis Embossing	A-5	T
17		Opener Lid	Chassis Embossing	A-5	T
17		Arm Assembly Pinch	Shaft	A-5	T
17		Lever T/Up / Arm T/Up	1 Hook	A-5	T
17,18		Belt Capstan/Motor Capstan	3 Screw	A-6	B
21		Lever F/R	Locking Tab	A-6	B
20, 21		Clutch Assembly D35	Washer	A-6	B
23		Brake Assembly Capstan	Locking Tab	A-6	B
24		Gear Drive/Gear Cam	Washer/Hook	A-7	B
25		Gear Sector	1 Hook	A-7	B
20,21,23, 24,25		Plate Slider	Shaft Guide	A-7	B
20,21,23, 24,25,26		Lever Tension	1 Hook	A-7	B
2,3,14,20, 21,25,23, 24,26		Lever Spring	Locking Tab	A7	B
25		Gear Assembly P2/Gear Assembly P3	Boss	A-8	B
2,3,14,25, 29		Base Assembly P2/Base Assembly P3	Chassis Slot	A-8	B
2,3,14,25, 29		Base Loading	1 Screw	A-9	T
2,3,14		Base Tension	Chassis Embossing	A-9	B
2,3,20,21, 22		Arm Assembly Idler	Locking Tab	A-9	T

T:Top, B:Bottom

NOTE : When reassembly perform the procedure in the reverse order.

- 1) When reassembling, confirm Mechanism and Mode Switch Alignment Position (Refer to Page 4-13)
- 2) When disassembling, the Parts for Starting No. Should be removed first.

DECK MECHANISM DISASSEMBLY

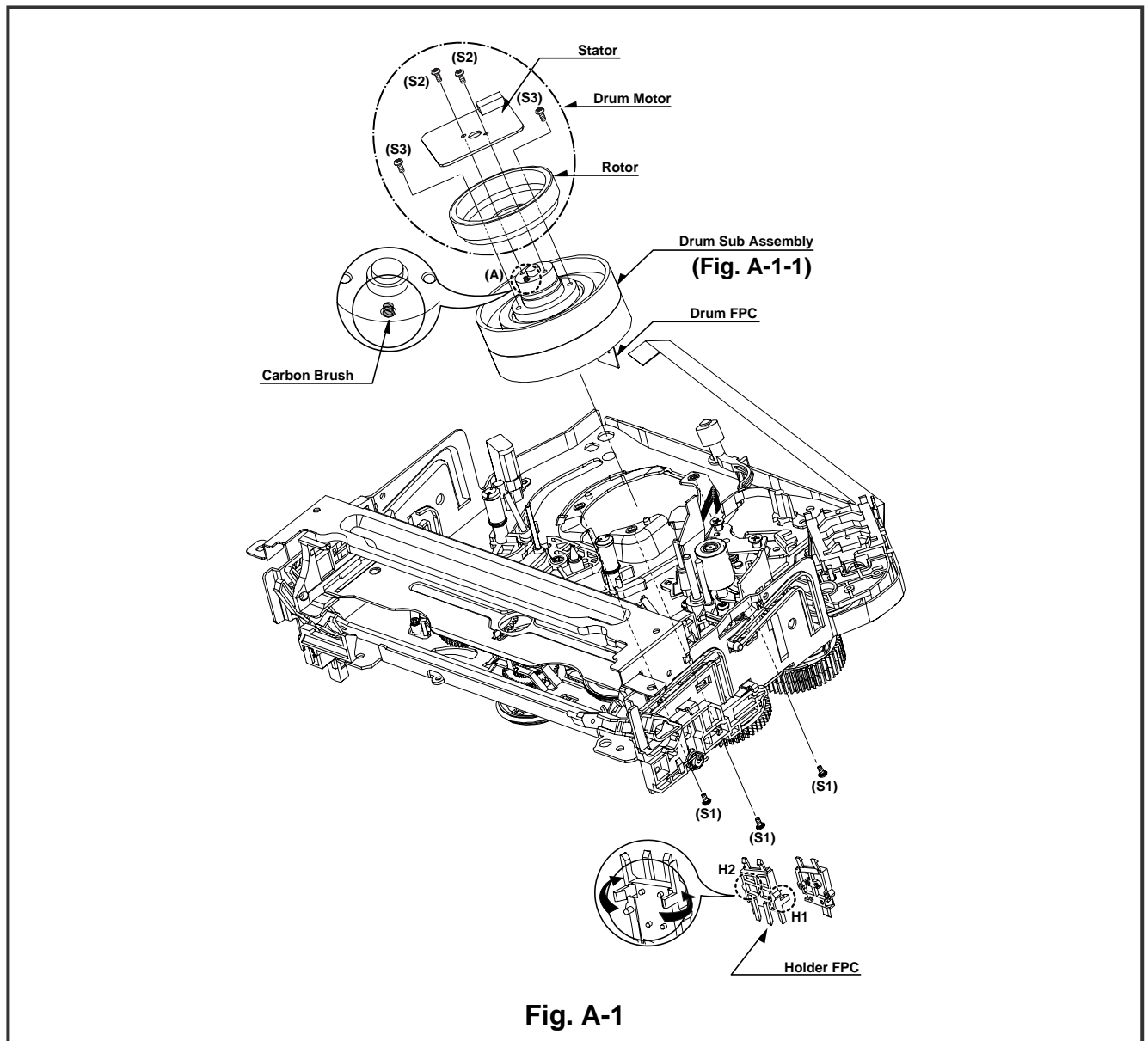

Fig. A-1

1. Drum Assembly (Fig. A-1-1)

- 1) Unplug the Drum FPC Connector.
- 2) Remove three Screws(S1) on bottom side and separate the Drum assembly.
- 3) Unhook (H1), (H2) and separate the Holder FPC and Cap FPC.

1-1. Drum Motor

- 1) Remove two Screws(S2) and disassemble the Stator of the Drum Motor.
- 2) Remove two Screws(S3) and separate the Rotor of the Drum Motor from the Drum Sub assembly.

NOTE

When reassembling, confirm (A) portion of the Drum Sub assembly whether the Carbon Brush is in there or not.

(Fig. B-1)

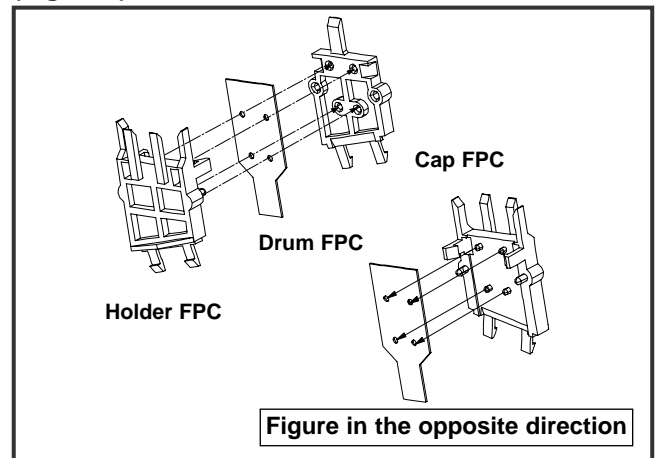

DECK MECHANISM DISASSEMBLY

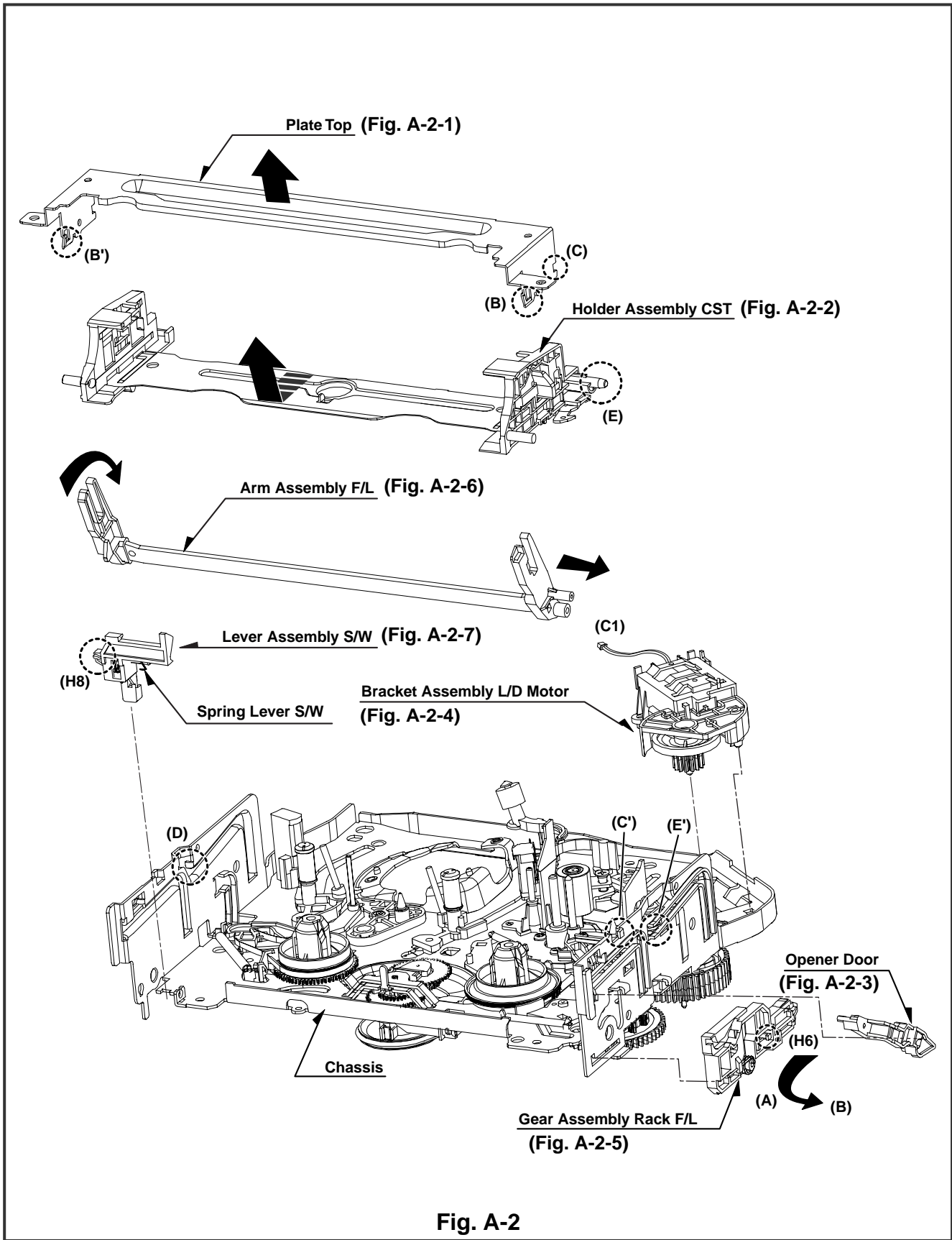

Fig. A-2

DECK MECHANISM DISASSEMBLY

2. Plate Top (Fig. A-2-1)

- 1) Pull the (B) portion of the Plate Top back in direction of arrow and separate the right side of it.
- 2) pull the (B') portion of the Plate Top back in direction of arrow and separate the left side of it.
(Used tools : (-) type driver, anything tool with sharp point or flat point.)

NOTE

- 1) When reassembling, push the Plate Top after alignment the two position(C), (C') as below Fig.

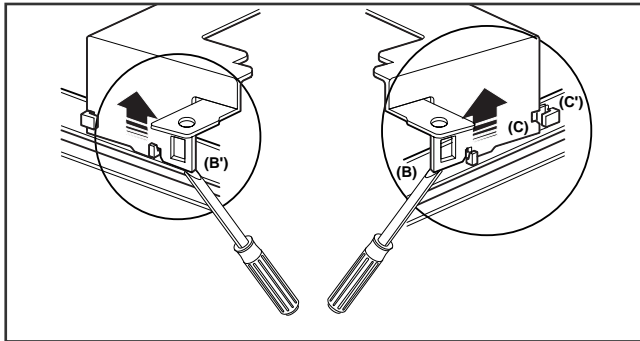

3. Holder Assembly CST (Fig.A-2-2)

- 1) Move the Holder Assembly CST in direction of arrow and separate the left side of it first through the (D) position of the Chassis.

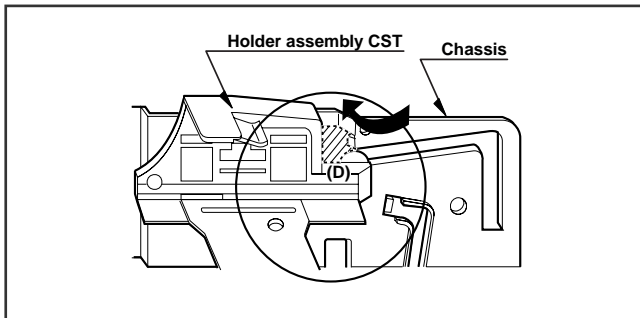

- 2) Disassemble the right side of the Holder Assembly CST from each guided hole of the Chassis.

NOTE

When reassembling, insert the (E) part of the Holder Assembly CST in the (E') hole of the Chassis first and assemble the left side of it.

4. Opener Door (Figure. A-2-3)

- 1) Turn the Opener Door clockwise and remove it through the guide hole of the Chassis.

5. Bracket Assembly L/D Motor (Fig. A-2-4)

- 1) Unplug the Connector(C1).

- 2) Unhook three Hooks(H3, H4, H5) on bottom side of the Chassis, lift up the Bracket Assembly L/M and disassemble the Bracket Assembly L/D Motor.

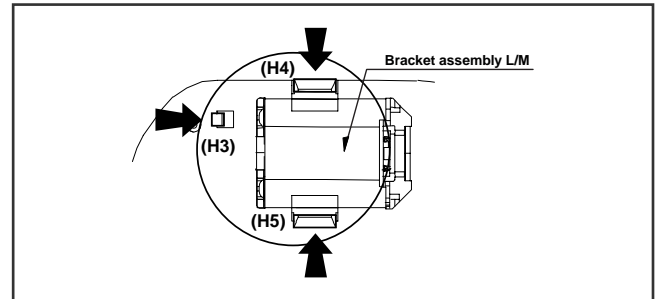

6. Gear Assembly Rack F/L (Fig. A-2-5)

- 1) Move the Gear Assembly Rack F/L in direction of arrow(A) and unhook the Hook(H6) pulling back in front.
- 2) Separate the Gear Rack F/L in direction of arrow(B).

NOTE

When reassembling, align the gear part of the Gear Assembly Rack F/L with the Gear Drive as below Fig.

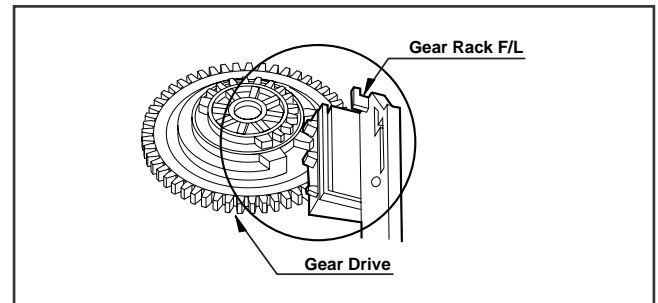

7. Arm Assembly F/L (Fig. A-2-6)

- 1) Move the Arm Assembly F/L in direction of arrow and separate the left side of it first.
- 2) Disassemble the Arm Assembly F/L from each guided hole of the Chassis.

8. Lever Assembly S/W(Fig. A-2-7)

- 1) Unhook the Hook(H8) in the left side of the Chassis and remove the Lever Assembly S/W.

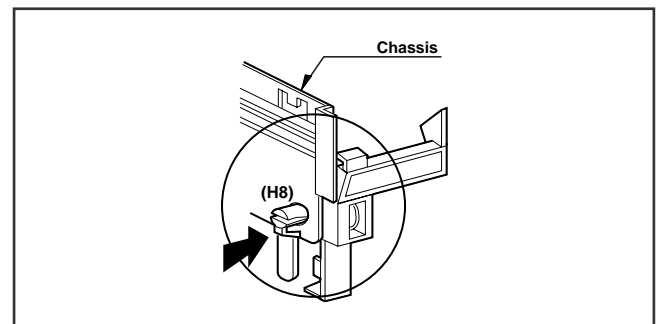

DECK MECHANISM DISASSEMBLY

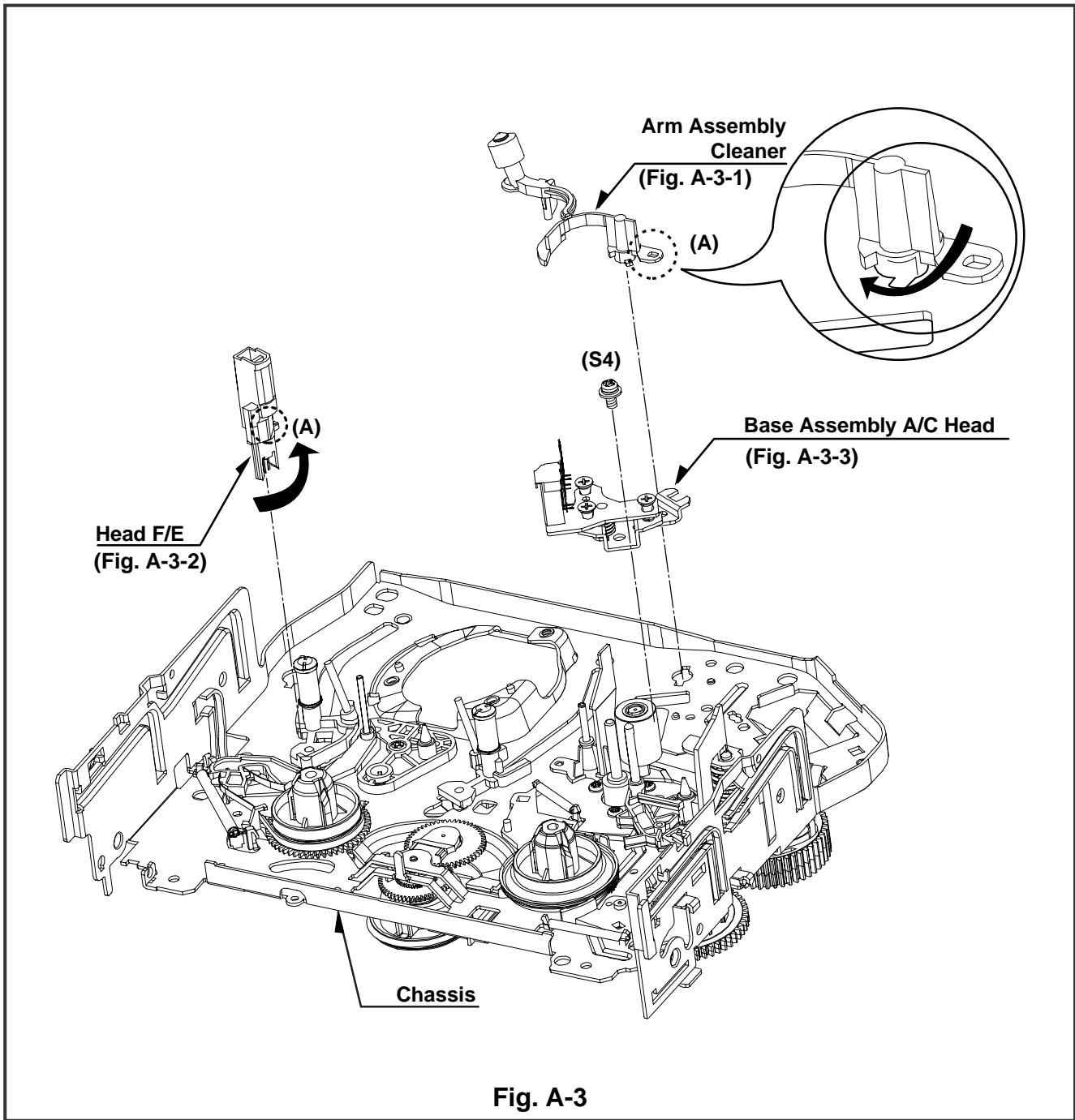

Fig. A-3

9. Arm Assembly Cleaner (Fig. A-3-1)

- 1) Breakaway the (A) portion as Fig. A-3-1 from the embossing of the Chassis, turn the Arm assembly Cleaner to clockwise direction and lift it up.

10. Head F/E (Fig. A-3-2)

- 1) Breakaway the (A) portion of the Head F/E from the embossing of the Chassis, turn it to counterclockwise direction and lift it up.

11. Base Assembly A/C Head (Fig. A-3-3)

- 1) Remove the Screw(S4) and lift the Base Assembly A/C Head up.

DECK MECHANISM DISASSEMBLY

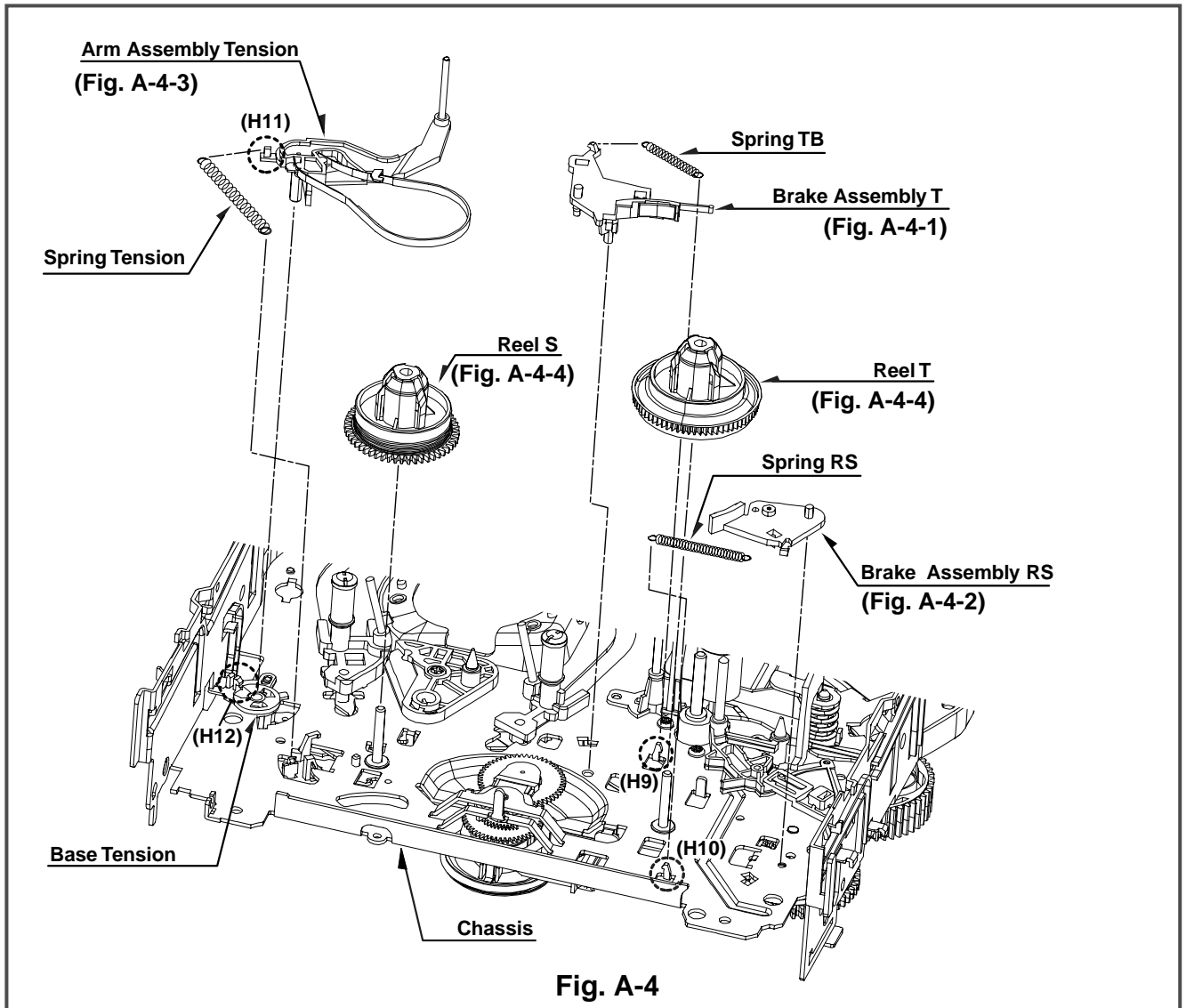

Fig. A-4

12. Brake Assembly T (Fig. A-4-1)

- 1) Unhook the Spring TB from the Hook(H9) of the Chassis.
- 2) Lift the Brake Assembly T up.

13. Brake Assembly RS (Fig. A-4-2)



- 1) Unhook the Spring RS from the Hook(H10) of the Chassis.
- 2) Lift the Brake Assembly T up.

14. Arm Assembly Tension (Fig. A-4-3)

- 1) Unhook the Spring Tension from the Hook(H11) of the Arm Assembly Tension.
- 2) Unhook the Hook(H12) of the Base Tension and lift the Arm Assembly Tension up.

NOTE

Difference for Springs

	Spring TB
	Spring RS Color (Black)
	Spring Tension

15. Reel S / Reel T (Fig. A-4-4)

- 1) Difference for Reel S / Reel T

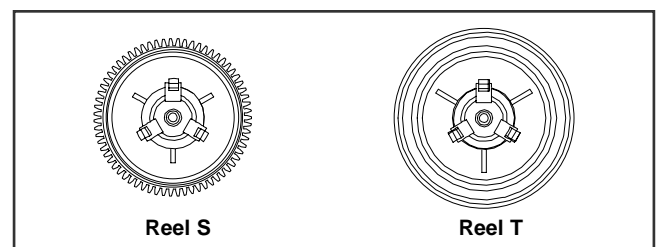

DECK MECHANISM DISASSEMBLY

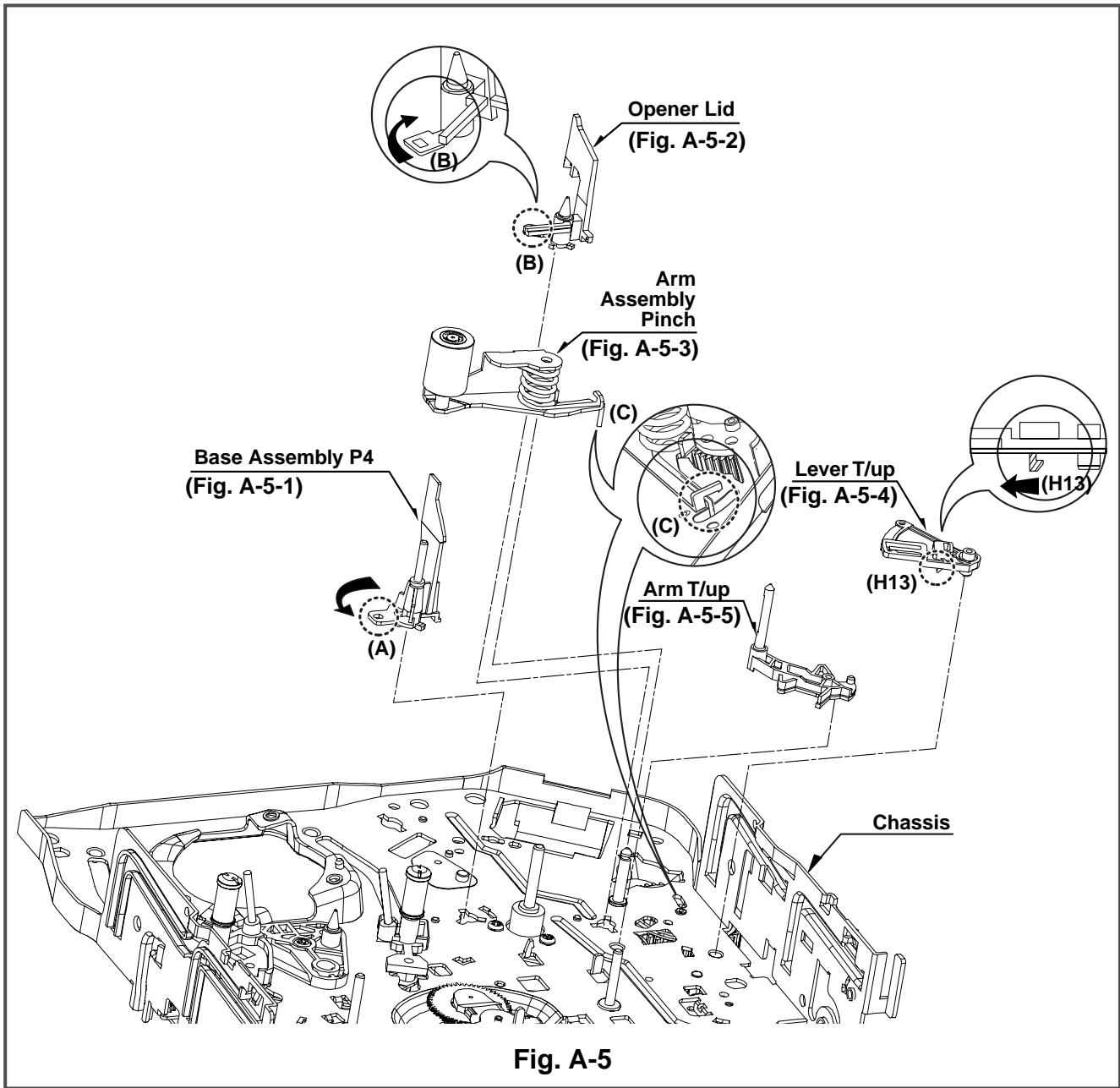

Fig. A-5

16. Base Assembly P4 (Fig. A-5-1)

- 1) Breakaway the (A) portion of the Base Assembly P4 from the embossing of the Chassis.
- 2) Turn the Base Assembly P4 to counterclockwise direction and lift it up.

17. Opener Lid (Fig. A-5-2)

- 1) Breakaway the (B) portion of the Opener Lid from the embossing of the Chassis.
- 2) Turn the Opener Lid to clockwise direction and lift it up.

18. Arm Assembly Pinch (Fig. A-5-3)

- 1) Lift the Arm Assembly Pinch up.

NOTE

When reassembling, confirm the (C) portion of the Arm Assembly Pinch is inserted to the Chassis hole correctly as Fig.

19. Lever T/up (Fig. A-5-4)/ Arm T/up (Fig. A-5-5)

- 1) Unhook the Hook(H13) of the bottom Chassis and lift the Lever T/up up.
- 2) Lift the Arm T/up up.

DECK MECHANISM DISASSEMBLY

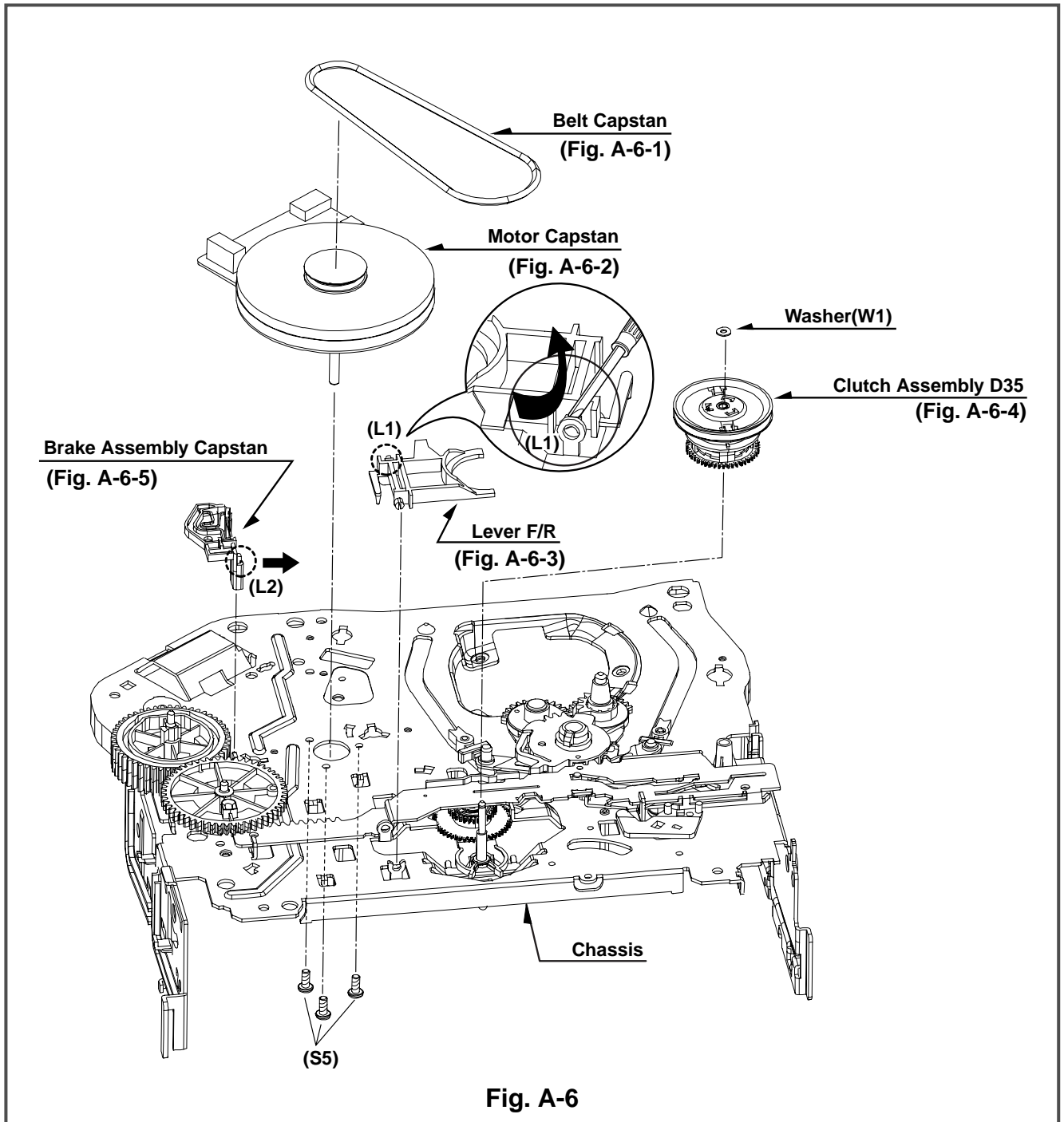

Fig. A-6

20. Belt Capstan (Fig. A-6-1)/ Motor Capstan (Fig. A-6-2)

- 1) Remove the Belt Capstan.
- 2) Remove the three Screws(S5) on bottom Chassis and lift the Motor Capstan up.

21. Lever F/R (Fig. A-6-3)

- 1) Unlock the Locking Tab(L1) as Fig. A-6-3 and lift the Lever F/R up.

22. Clutch Assembly D35 (Fig. A-6-4)

- 1) Remove the Washer(W1) and lift the Clutch Assembly D35 up.

23. Brake Assembly Capstan (Fig. A-6-5)

- 1) Pull the Locking Tab(L2) back in direction of arrow and lift it up.

DECK MECHANISM DISASSEMBLY

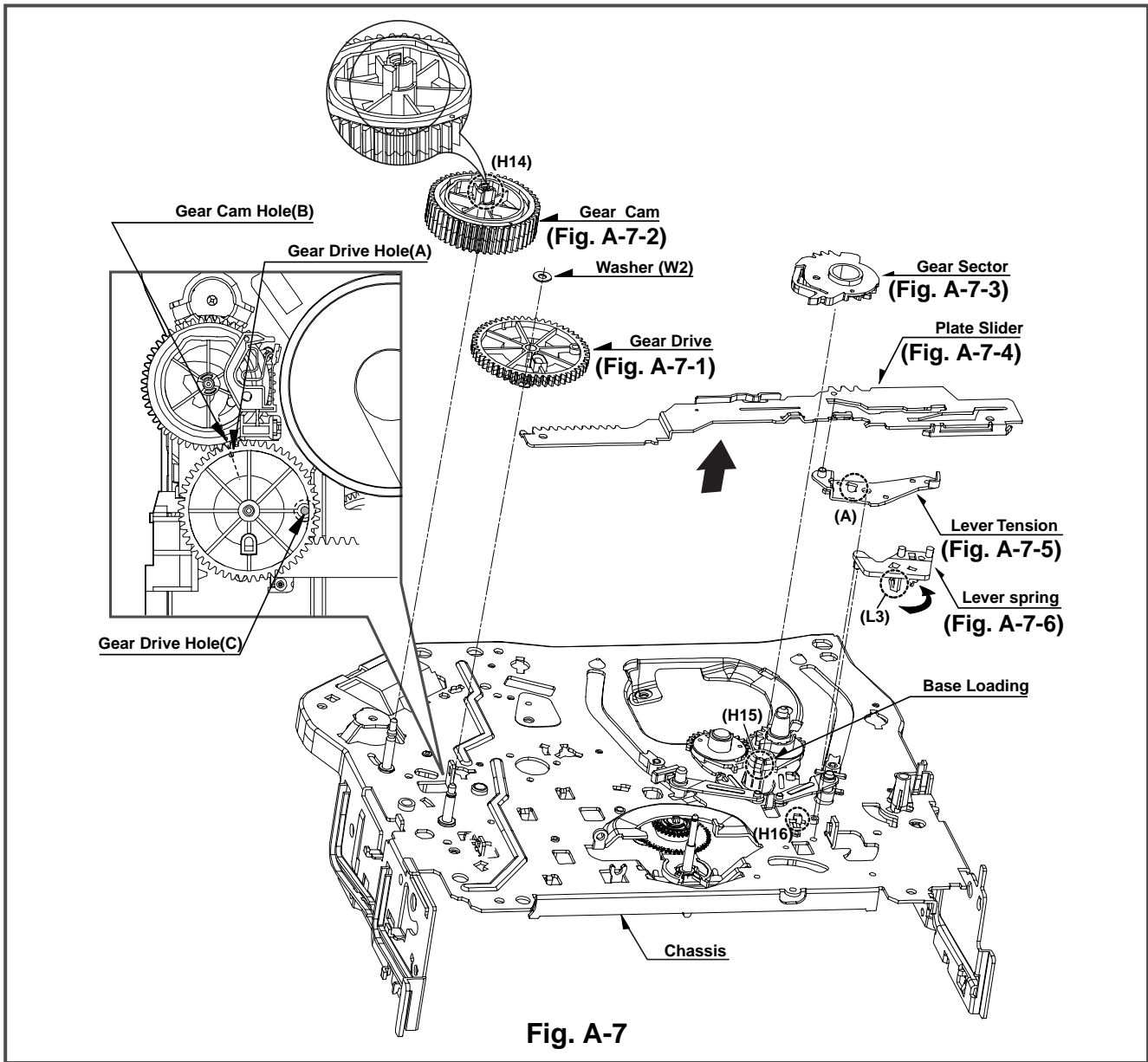

Fig. A-7

24. Gear Drive (Fig. A-7-1)/ Gear Cam (Fig. A-7-2)

- 1) Remove the Washer(W2) and lift the Gear Drive up.
- 2) Unhook the Hook(H14) of the Gear Cam and lift the Gear Cam up.

NOTE

When reassembling, align the Gear Drive Hole(A) and the Gear Cam Hole(B) in a straight line after the Gear Drive Hole(C) is aligned with the Chassis Hole as Fig.

25. Gear Sector (Fig. A-7-3)

- 1) Unhook the Hook(H15) of the Base Loading on bottom Chassis and lift the Gear Sector up.

26. Plate Slider (Fig. A-7-4)

- 1) Just lift the Plate Slider up.

27. Lever Tension (Fig. A-7-5)

- 1) Unhook the (A) portion of the Lever Tension from the Hook(H16) of the Chassis.
- 2) Turn the Lever Tension to counterclockwise direction and lift it up.

28. Lever Spring (Fig. A-7-6)

- 1) Unlock the Locking Tab(L3) of the bottom Chassis and lift the Lever Spring up.

DECK MECHANISM DISASSEMBLY

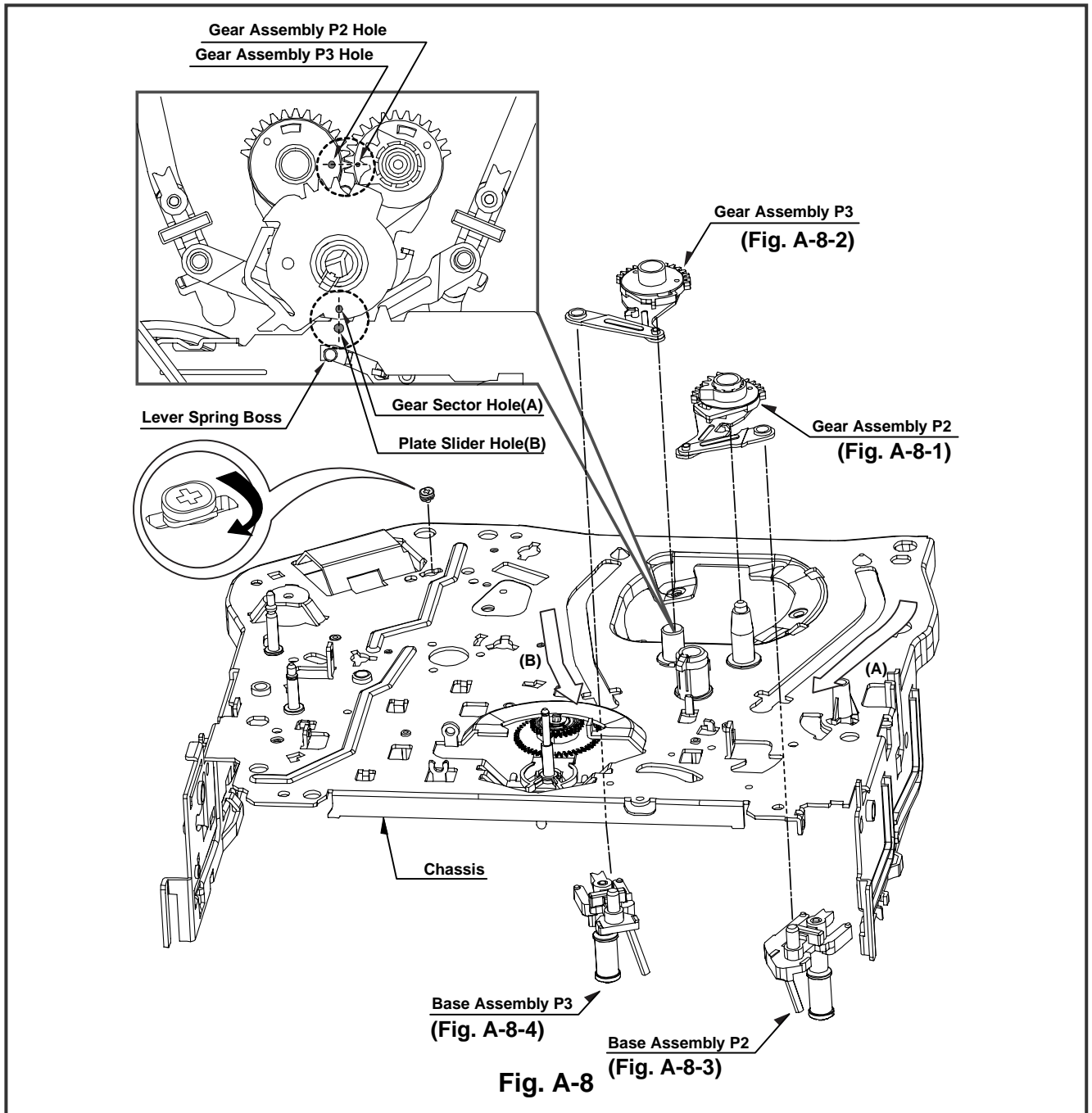

Fig. A-8

29. Gear Assembly P2 (Fig. A-8-1)/ Gear Assembly P3 (Fig. A-8-2)

- 1) Just lift the Gear Assembly P2 up.
- 2) Just lift the Gear Assembly P3 up.

NOTE

When reassembling, align the two holes of the Gear Assembly P2 and P3 in a straight line after confirmation whether the Gear Sector Hole(A) and the Plate Slider Hole(B) are aligned or not as Fig.

30. Base Assembly P2 (Fig. A-8-3)/ Base Assembly P3 (Fig. A-8-4)

- 1) Move the Base Assembly P2 in direction of arrow(A) along the guide hole of the Chassis and disassemble it on bottom side.
- 2) Move the Base Assembly P3 in direction of arrow(B) along the guide hole of the Chassis and disassemble it on bottom side.

DECK MECHANISM DISASSEMBLY

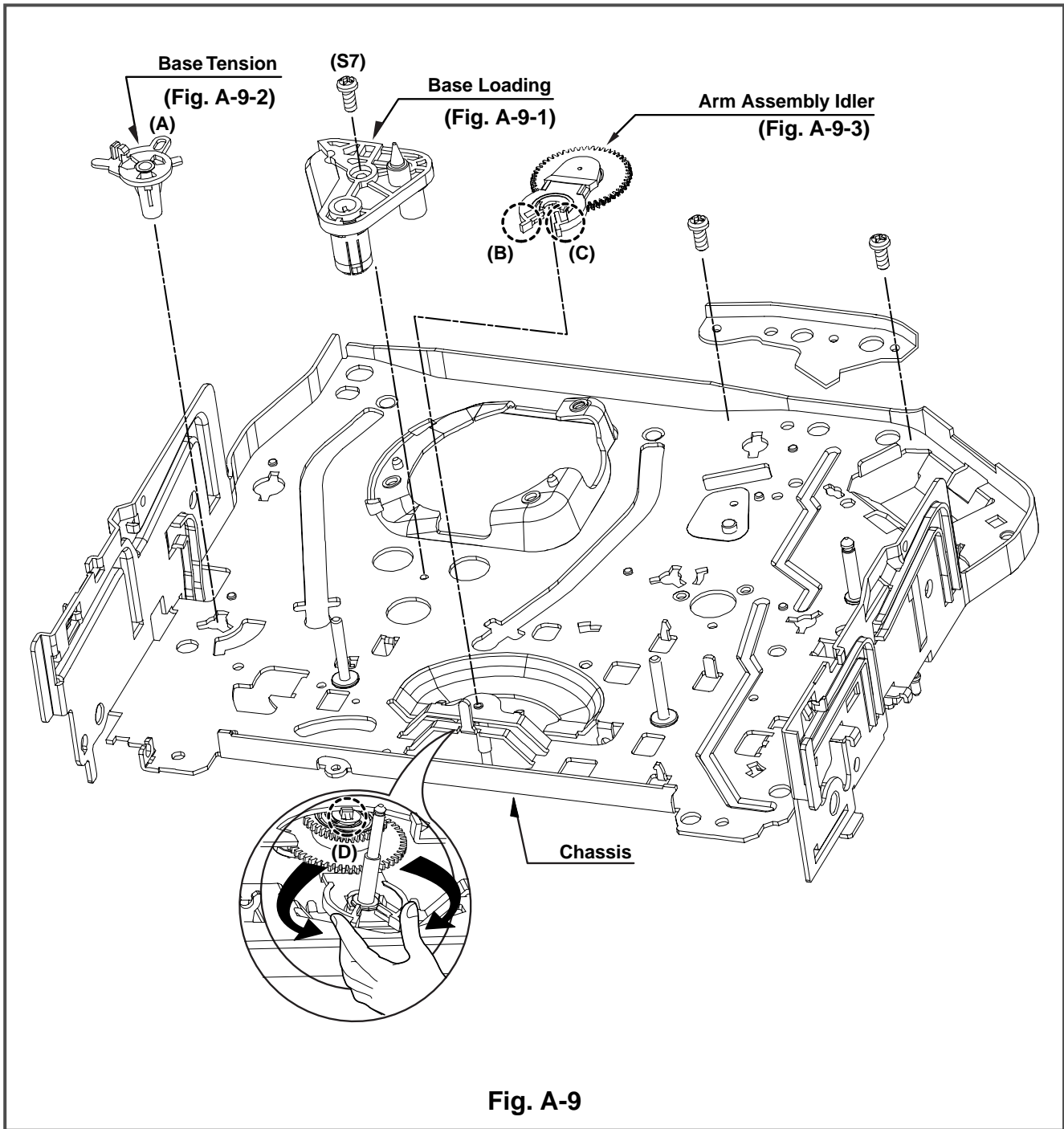

Fig. A-9

31. Base Loading (Fig. A-9-1)

- 1) Remove the Screw(S7).
- 2) Lift the Base Loading up.

32. Base Tension (Fig. A-9-2)

- 1) Breakaway the (A) portion of the Base Tension from the embossing of the Chassis.
- 2) Turn the Base Tension to counterclockwise direction and lift it up.

33. Arm Assembly Idler (Fig. A-9-3)

- 1) Make narrower the two parts, (B) and (C), as Fig. A-9-3.
- 2) Lift the Arm assembly Idler up.

NOTE

When disassembling, be careful not to be caught the (D) part by the Chassis as Fig.

DECK MECHANISM ADJUSTMENT

- Tools and Fixfures for Service

**1. Cassette Torque Meter
PUJ42881**

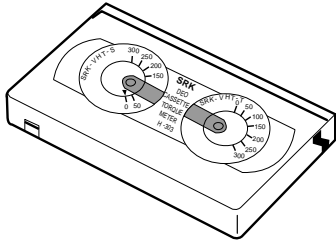

**2. Alignment Tape
NTSC: MHP
PAL:MHPE**

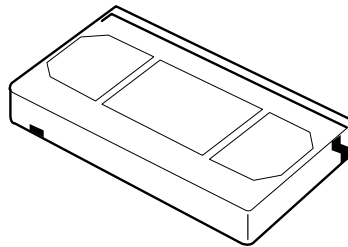

**3. Torque Gauge
PUJ48075-2**

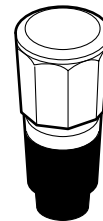

**4. Post Height Adjusting Driver
(Roller driver)
PTU94002**

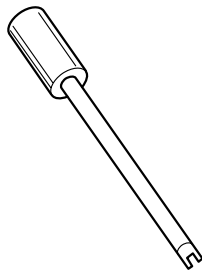

DECK MECHANISM ADJUSTMENT

1. Mechanism Alignment Position Check

Purpose: To determine if the Mechanism is in the correct position, when a Tape is ejected.

Test Equipment/ Fixture	Test Conditions (Mechanism Condition)	Check Point
• Blank tape	• Eject Mode (with Cassette ejected)	• Mechanism and Mode Switch Position

- 1) Turn the Power S/W on and eject the Cassette by pressing the Eject Button.
- 2) Remove the Top Cover and Plate Assembly Top, visually check if the Gear Cam is aligned with the Chassis Hole as below Fig. C-2.
- 3) IF not, rotate the Shaft of the Loading Motor to either clockwise or counterclockwise until the alignment is as below Fig. C-2.
- 4) Remove the Screw which fixes the Deck Mechanism and Main Frame and confirm if the Gear Cam is aligned with the Gear Drive as below Fig. C-1(A).
- 5) Confirm if the Mode S/W on the Main P.C.Board is aligned as below Fig. C-1(B).
- 6) Remount the Deck Mechanism on the Main P.C.Board and check each operation.

CHECK DIAGRAM

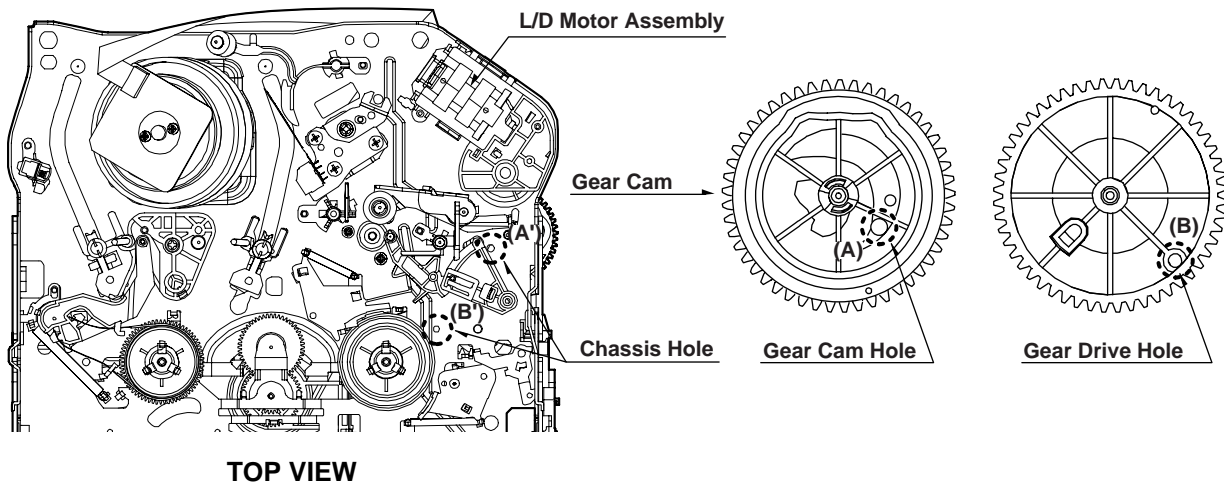
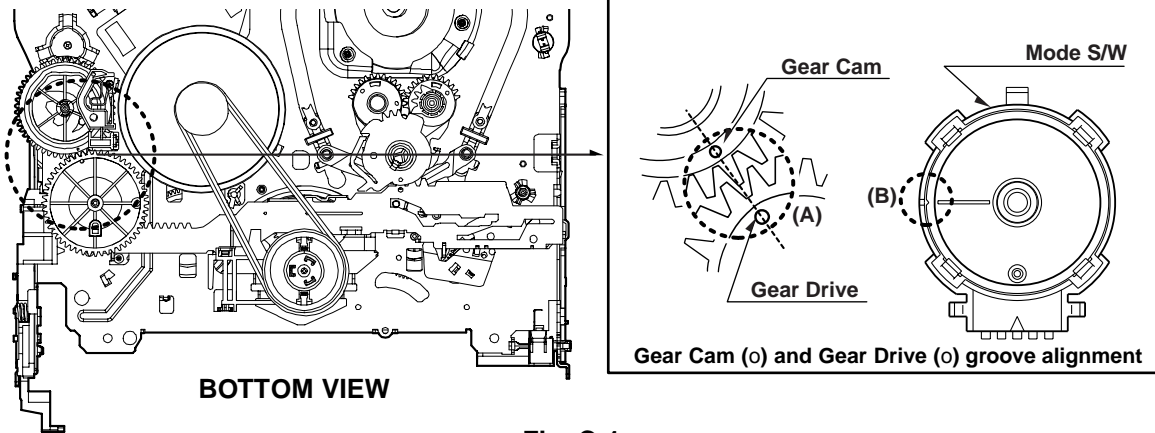

DECK MECHANISM ADJUSTMENT

2. Preparation for Adjustment (To set the Deck Mechanism of the loading state without inserting a cassette tape).

- 1) Unplug the power cord from the AC outlet.
- 2) Disassemble the Top Cover and Plate Assembly Top.
- 3) Plug the power cord into the AC outlet.
- 4) Turn the power S/W on and push the Lever Stopper of the Holder Assembly CST to the back for loading the

cassette without tape.

Cover the holes of the End Sensors at the both sides of the Chassis to prevent a light leak.

Then the Deck Mechanism drives to the Stop Mode. In this case, the Deck Mechanism can accept inputs of each mode, however the Rewind and Review operation can not be performed for more than a few seconds because the Take-up Reel Table is in the Stop State and can not be detected the Reel Pulses.

3. Checking Torque

Purpose: To insure smooth transport of the tape during each mode of operation.
If the tape transport is abnormal, then check the torque as indicated by the chart below.

Test Equipment/ Fixture	Test Conditions (Mechanism Condition)	Checking Method		
<ul style="list-style-type: none"> • Torque Gauge(600g/cm ATG) • Torque Gauge Adaptor • Cassette Torque Meter SRK-VHT-303 	<ul style="list-style-type: none"> • Play (FF) or Review (REW) Mode 	<ul style="list-style-type: none"> • Perform each Deck Mechanism mode without inserting a cassette tape(Refer to above No.2 Preparation for Adjustment). • Read the measurement of the Take-up or Supply Reels on the Cassette Torque Meter(Fig. C-3-2). • Attach the Torque Gauge Adaptor to the Torque Gauge and then read the value of it(Fig. C-3-1). 		
Item	Mode	Test Equipment	Measurement Reel	Measurement Values
Fast Forward Torque	Fast Forward	Cassette Torque Gauge	Take-Up Reel	More than 400g/cm
Rewind Torque	Rewind	Cassette Torque Gauge	Supply Reel	More than 400g/cm
Play Take-Up Torque	Play	Cassette Torque Meter	Take-Up Reel	40~100g/cm
Review Torque	Review	Cassette Torque Meter	Supply Reel	120~210g/cm

NOTE:

The values are measured by using a Torque Gauge and Torque Gauge Adaptor with the Torque Gauge affixed.

• Torque Gauge (600g.cm ATG)

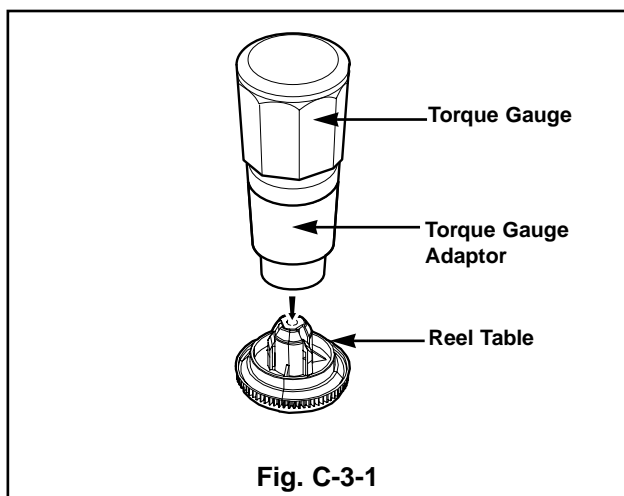

Fig. C-3-1

NOTE:

The torque reading to measure occurs when the tape abruptly changes direction from Fast Forward to Rewind Mode, when quick braking is applied to both Reels.

• Cassette Torque Meter (SRK-VHT-303)

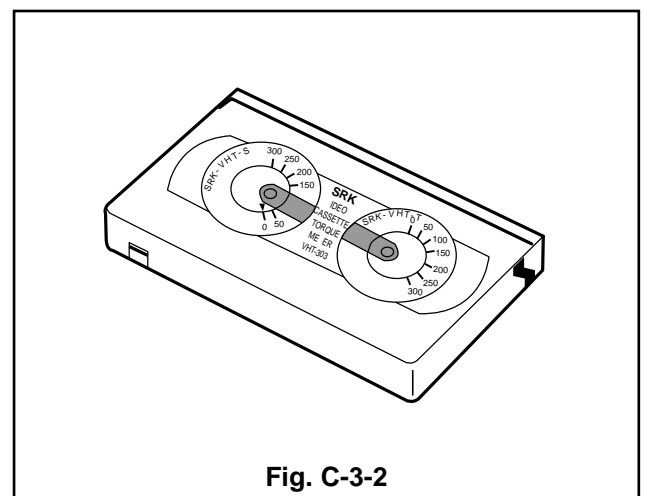

Fig. C-3-2

DECK MECHANISM ADJUSTMENT

4. Guide Roller Height Adjustment

Purpose: To regulate the height of the tape so that the bottom of the tape runs along the tape guide line on the Lower Drum.

4-1. Preliminary Adjustment

Test Equipment/ Fixture	Test Conditions (Mechanism Condition)	Adjustment Point
• Post Height Adjusting Driver	• Play or Review Mode	• Guide Roller Height Adjustment screws on the Supply and Take-Up Guide Rollers.

Adjustment Procedure

- 1) Confirm if the tape runs along the tape guide line of the Lower Drum.
- 2) If the tape runs the bottom of the guide line, turn the Guide Roller Height Adjustment Screw to clockwise direction.
- 3) If it runs the top, turn to counterclockwise direction.
- 4) Adjust the height of the Guide Roller to be guided to the guide line of the Lower Drum from the starting and ending point of the Drum.

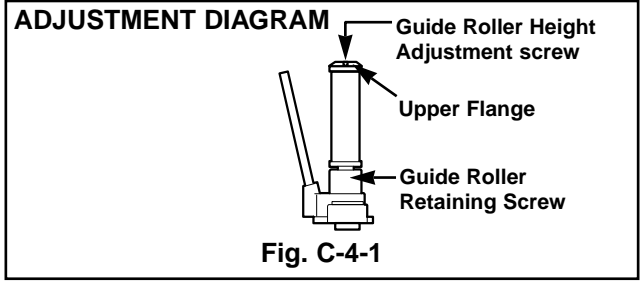

4-2. Precise Adjustment

Test Equipment/Fixture	Test Equipment Connection Points	Test Conditions VCR(VCP) State	Adjustment Point
• Oscilloscope • Alignment Tape • Post Height Adjusting Driver	• CH-1:PB RF Envelope • CH-2:NTSC: SW 30Hz PAL: SW 25Hz • Head Switching Output Point • RF Envelope Output Point	• Play an Alignment Tape	• Guide Roller Height Adjustment Screws

Adjustment Procedure

- 1) Play an Alignment Tape after connecting the probe of the Oscilloscope to the RF Envelope Output Test Point and Head Switching Output Test Point.
- 2) Tracking Control(in PB Mode) : Center Position(When this adjustment is performed after the Drum Assembly has been replaced, set the Tracking Control so that the RF Output is Maximum).
- 3) Height Adjustment Screw : Flatten the RF waveform. (Fig. C-4-2)
- 4) Turn(Move) the Tracking Control(in PB Mode) clockwise and counterclockwise.(Fig. C-4-3)
- 5) Check that any drop of RF Output is uniform at the start and end of the waveform.

NOTE

If the adjustment is excessive or insufficient the tape will jam or fold.

Waveform Diagrams

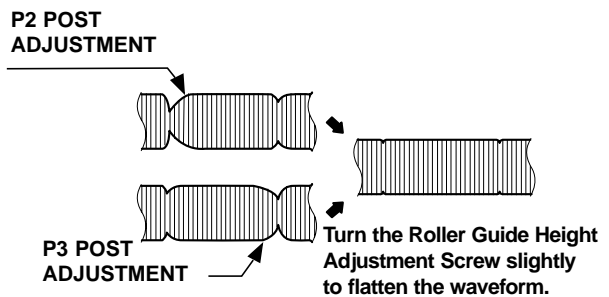

Fig. C-4-2

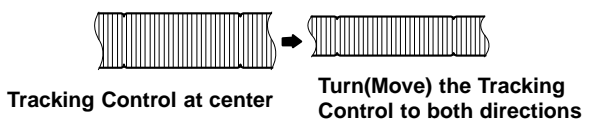
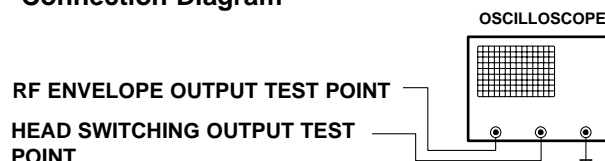

Fig. C-4-3

Connection Diagram



DECK MECHANISM ADJUSTMENT

5. Audio/Control (A/C) Head Adjustment

Purpose: To insure that the tape passes accurately over the Audio and Control Tracks in exact alignment of the both Record and Playback Modes.

5-1. Preliminary Adjustment (Height and Tilt Adjustment)

Perform the Preliminary Adjustment, when there is no Audio Output Signal with the Alignment Tape.

Test Equipment/ Fixture	Test Conditions (Mechanism Condition)	Adjustment Point
<ul style="list-style-type: none"> • Blank Tape • Screw Driver(+) Type 5mm 	<ul style="list-style-type: none"> • Play the blank tape 	<ul style="list-style-type: none"> • Tilt Adjustment Screw(C) • Height Adjustment Screw(B) • Azimuth Adjustment Screw(A)

Adjustment Procedure/Diagrams

- 1) Initially adjust the Base Assembly A/C Head as shown Fig. C-5-1 by using the Height Adjustment Screw(B).
- 2) Play a blank tape and observe if the tape passes accurately over the A/C Head without tape curling or folding.
- 3) If folding or curling is occurred then adjust the Tilt Adjustment Screw(C) while the tape is running to resemble Fig. C-5-3.

- 4) Reconfirm the tape path after Playback about 4~5 seconds.

NOTE

Ideal A/C head height occurs when the tape runs between 0.2~0.25mm above the bottom edge of the A/C Head core.

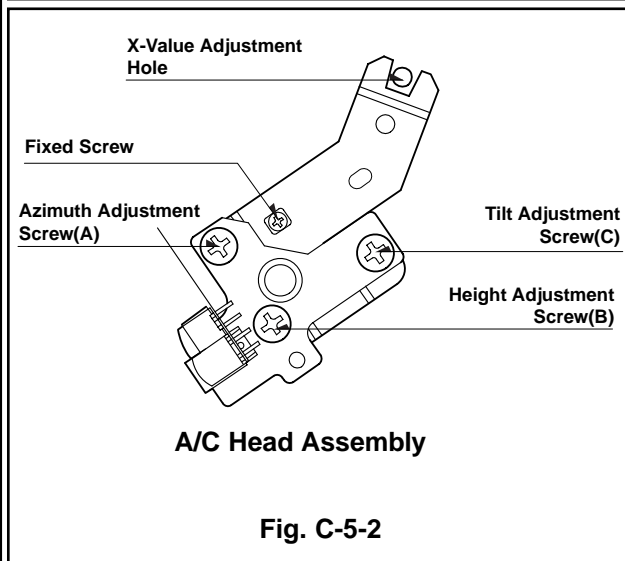
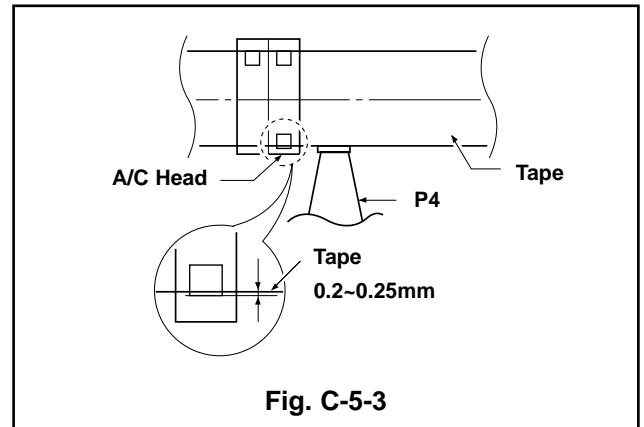
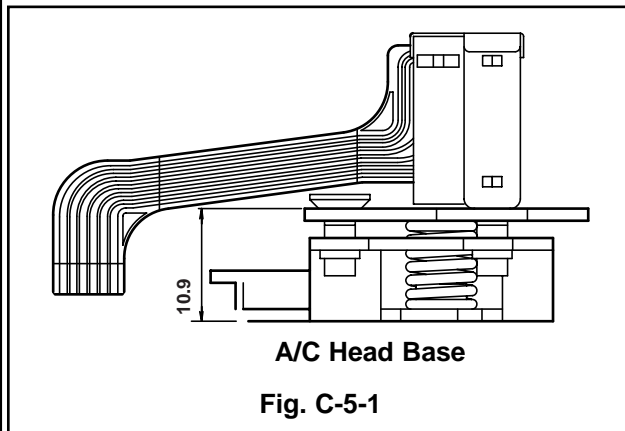

DECK MECHANISM ADJUSTMENT

5-2. Confirm that the tape passes smoothly between the Take-up Guide and Pinch Roller(using a mirror or the naked eye).

- 1) After completing Step 5-1.(Preliminary Adjustment), check that the tape passes around the Take-up Guide and Pinch Roller without folding or curling at the top or bottom.
 - (1) If folding or curling is observed at the bottom of the Take-up Guide then slowly turn the Tilt Adjustment Screw(C) in the clockwise direction.

- (2) If folding or curling is observed at the top of it then slowly turn the Tilt Adjustment Screw(C) in the counterclockwise direction.

NOTE:

Check the RF envelope after adjusting the A/C Head, if the RF waveform differs from Fig. C-5-4, performs Precise Adjustment to flat the RF waveform.

5-3. Precise Adjustment (Azimuth adjustment)

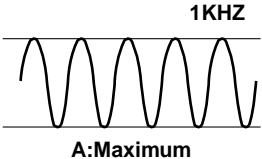
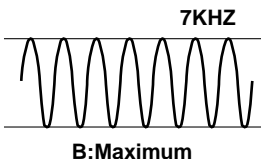
Test Equipment/ Fixture	Connection Point	Test Conditions (Mechanism Condition)	Adjustment Point
<ul style="list-style-type: none"> • Oscilloscope • Alignment Tape(SP) • Screw Driver(+) Type 5mm 	<ul style="list-style-type: none"> • Audio output jack 	<ul style="list-style-type: none"> • Play an Alignment Tape 1KHz, 7KHz Sections 	<ul style="list-style-type: none"> • Azimuth Adjustment Screw(A) • Height Adjustment Screw(B)
Adjustment Procedure <ol style="list-style-type: none"> 1) Connect the probe of the oscilloscope to Audio Output Jack. 2) Alternately adjust the Azimuth Adjustment Screw(A) and the Tilt Adjustment Screw(C) for maximum output of the 1KHz and 7KHz segments, while maintaining the flattest envelope differential between the two frequencies. 			
			
Fig. C-5-4			

6. X-Value Adjustment

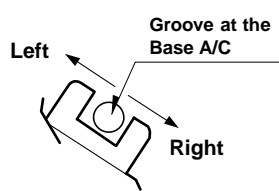
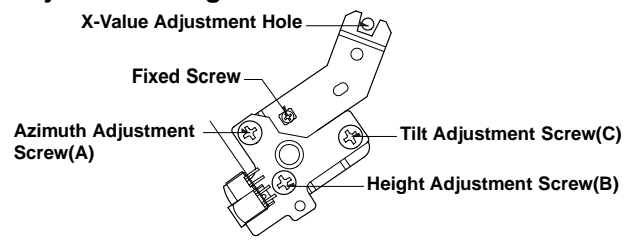
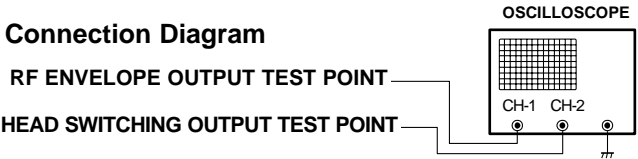
Purpose: To obtain compatibility with the other VCR(VCP) Models.			
Test Equipment/ Fixture	Connection Point	Test Conditions (Mechanism Condition)	Adjustment Point
<ul style="list-style-type: none"> • Oscilloscope • Alignment Tape(SP only) • Screw Driver(+) Type 5mm 	<ul style="list-style-type: none"> • CH-1: PB RF Envelope • CH-2: NTSC: SW 30Hz PAL: SW 25Hz • Head Switching Output Test Point • RF Envelope Output Test Point 	<ul style="list-style-type: none"> • Play an Alignment Tape 	
Adjustment Procedure <ol style="list-style-type: none"> 1) Release the Automatic Tracking to run long enough for tracking to complete it's cycle. 2) Loosen the Fixed Mounting Screw and move the Base Assembly A/C Head in the direction as shown in the diagram to find the center of the peak that allows for the maximum waveform envelope. This method should allow the 31µm Head to be centrally located over the 58µm tape track. 3) Tighten the Base Assembly A/C Head mounting Screw. 		Adjustment Diagram 	
		Connection Diagram 	

DECK MECHANISM ADJUSTMENT

7. Adjustment after Replacing Drum Assembly (Video Heads)

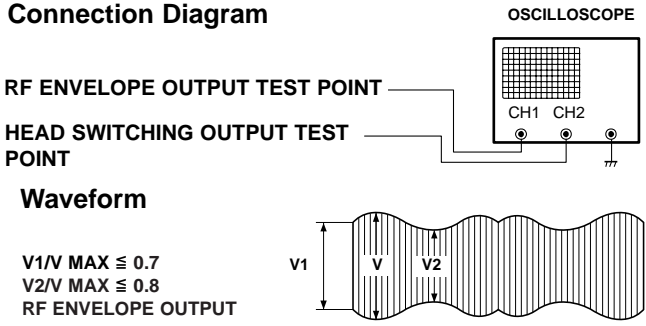
Purpose: To correct for shift in the Roller Guide and X value after replacing the Drum.			
Test Equipment/ Fixture	Connection Point	Test Conditions (Mechanism Condition)	Adjustment Points
<ul style="list-style-type: none"> Oscilloscope Alignment Tapes Blank Tape Post Height Adjusting Driver Screw Driver(+) Type 5mm 	<ul style="list-style-type: none"> CH-1: PB RF Envelope CH-2: NTSC: SW 30Hz PAL: SW 25Hz Head Switching Output Test Point RF Envelope Output Test Point 	<ul style="list-style-type: none"> Play the Blank Tape Play an Alignment Tape 	<ul style="list-style-type: none"> Guide Roller Precise Adjustment Switching Point Tracking Preset X-Value
Checking/Adjustment Procedure Play a blank tape and check for tape curling or creasing around the Roller Guide. If there is a problem then follow the procedure 4. "Guide Roller Height" and 5. "Audio Control(A/C) Head Adjustment".		Connection Diagram  <p>Waveform</p> <p>V1/V MAX \leq 0.7 V2/V MAX \leq 0.8 RF ENVELOPE OUTPUT</p>	
Fig. C-7			

8. Check the Tape Travel after Reassembling Deck Assembly.

8-1. Checking Audio and RF Locking Time during playback and after CUE or REV (FF/REW)

Test Equipment/ Fixture	Specification	Connection Points	Test Conditions (Mechanism Condition)
<ul style="list-style-type: none"> Oscilloscope Alignment Tapes(with 6H 3KHz Color Bar Signal) Stop Watch 	<ul style="list-style-type: none"> RF Locking Time: Less than 5 sec. Audio Locking Time:Less than 10sec 	<ul style="list-style-type: none"> CH-1: PB RF Envelope CH-2: Audio Output RF Envelope Output Point Audio Output Jack 	<ul style="list-style-type: none"> Play an Alignment Tape (with 6H 3kHz Color Bar Signal)
Checking Procedure Play an Alignment Tape then change the operating mode to CUE or REV and confirm if the unit meets the above listed specifications.		NOTES: 1) CUE is the forward search mode 2) REV is the backward search mode 3) Refer to the Play mede	

8-2. Checking for tape curling or jamming

Test Equipment/ Fixture	Specification	Test Conditions (Mechanism Condition)
<ul style="list-style-type: none"> T-160 Tape T-120 Tape 	<ul style="list-style-type: none"> Be sure there is no tape jamming or curling at the beginning, middle or end of the tape. 	<ul style="list-style-type: none"> Run the CUE, REV, Play mode at the beginning and the end of the tape.
Checking Procedure 1) Confirm that the tape runs smoothly around the roller guides, Drum and A/C Head Assemblies while abruptly changing operating modes from Play to CUE or REV. This is to be checked at the beginning, middle and end sections of the tape. 2) Confirm that the tape passes over the A/C Head Assembly as indicated by proper audio reproduction and proper tape counter performance.		

MAINTENANCE/INSPECTION PROCEDURE

1. Check before starting repairs

The following faults can be remedied by cleaning and oiling. Check the needed lubrication and the conditions of cleanliness in the unit.

Check with the customer to find out how often the unit is used, and then determine that the unit is ready for inspection and maintenance. Check the following parts.

Phenomenon	Inspection	Replacement
Color beats	Dirt on Full-Erase Head	o
Poor S/N, no color	Dirt on Video Head	o
Vertical or Horizontal jitter	Dirt on Video Head Dirt on tape transport system	o
Low volume, Sound distorted	Dirt on Audio/Control Head	o
Tape does not run. Tape is slack	Dirt on Pinch Roller	o
In Review and Unloading (off mode), the tape is rolled up loosely.	Clutch Assembly D35 torque reduced	o
	Cleaning Drum and transport system	Fig. C-9-3

F/E Head
Video Head
A/C Head
Pinch Roller
Belt Capstan
Clutch Assembly D35

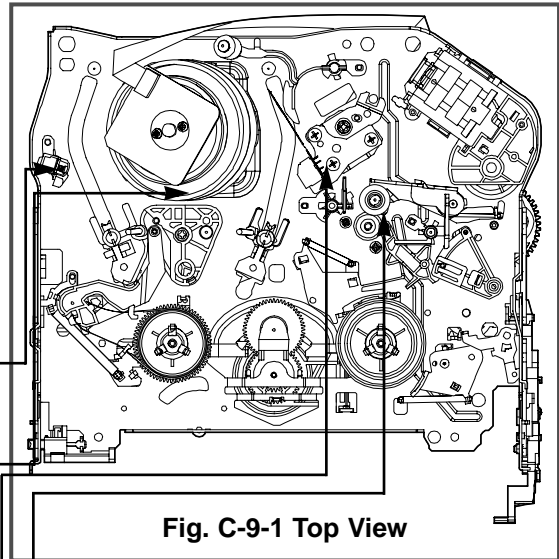

Fig. C-9-1 Top View

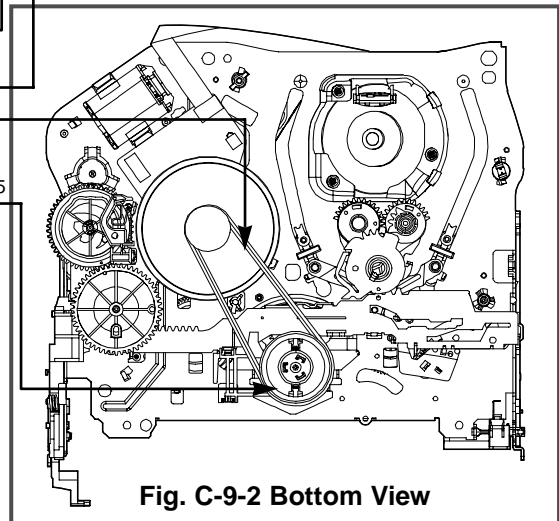

Fig. C-9-2 Bottom View

NOTE

If locations marked with o do not operate normally after cleaning, check for wear and replace.

See the EXPLODED VIEWS at the end of this manual as well as the above illustrations and see the Greasing (Page 4-21, 22) for the sections to be lubricated and greased.

* No. (1)~(12) Indicates the Tape Path to be traveled from Supply Reel to Take-up Reel.

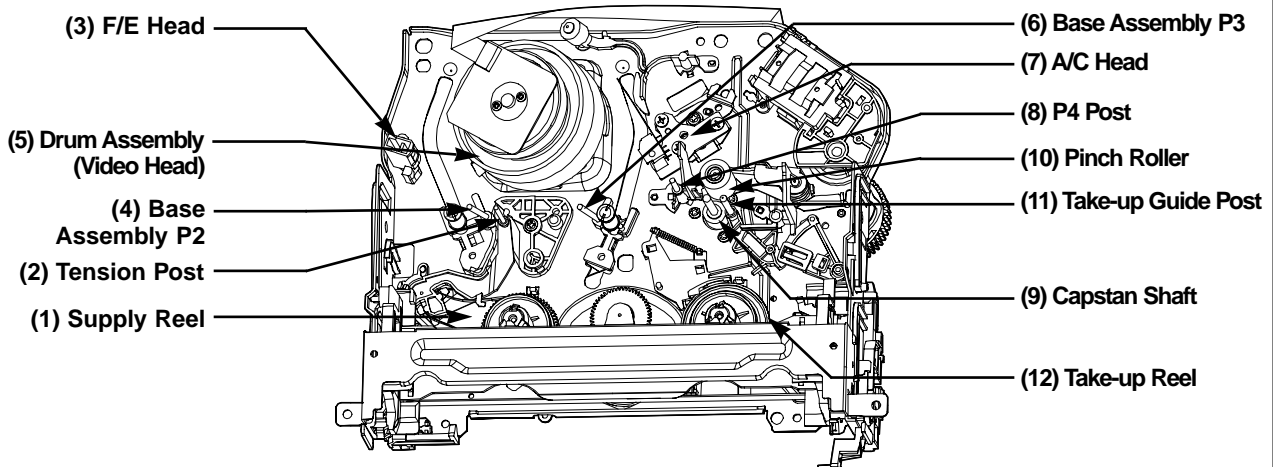

Fig. C-9-3 Tape Transport System

MAINTENANCE/INSPECTION PROCEDURE

2. Required Maintenance

The recording density of a VCR(VCP) is much higher than that of an audio tape recorder. VCR(VCP) components must be very precise, at tolerances of 1/1000mm, to ensure compatibility with the other VCRs. If any of these components are worn or dirty, the symptoms will be the same as if the part is defective. To ensure a good picture, periodic inspection and maintenance, including replacement of worn out parts and lubrication, is necessary.

3. Scheduled Maintenance

Schedules for maintenance and inspection are not fixed because they vary greatly according to the way in which the customer uses the VCR(VCP), and the environment in which the VCR(VCP) is used.

But, in general home use, a good picture will be maintained if inspection and maintenance is made every 1,000 hours. The table below shows the relation between time used and inspection period.

Table 1

When inspection is necessary / Average hours used per day	About 1 year	About 18 months	About 3 years
One hour	[Solid black bar]		
Two hours	[Solid black bar]		
Three hours	[Solid black bar]		

4. Supplies Required for Inspection and Maintenance

- (1) Grease : Kanto G-311G (Blue) or equivalent
- (2) Isopropyl Alcohol or equivalent
- (3) Cleaning Patches
- (4) Grease : Kanto G-381(Yellow)

5. Maintenance Procedure

5-1) Cleaning

- (1) Cleaning video head

First use a cleaning tape. If the dirt on the head is too stubborn to remove by tape, use the cleaning patch. Coat the cleaning patch with Isopropyl Alcohol. Touch the cleaning patch to the head tip and gently turn the head(rotating cylinder) right and left.

(Do not move the cleaning patch vertically. Make sure that only the buckskin on the cleaning patch comes into contact with the head. Otherwise, the head may be damaged.)

Thoroughly dry the head. Then run the test tape. If Iso-propyl Alcohol remains on the video head, the tape may be damaged when it comes into contact with the head surface.

- (2) Clean the tape transport system and drive system, etc, by wiping with a cleaning patch wetted with Isopropyl Alcohol.

NOTES:

- ① It is the tape transport system which comes into contact with the running tape. The drive system consists of those parts which moves the tape.
- ② Make sure that during cleaning you do not touch the tape transport system with excessive force that would cause deformation or damage to the system.

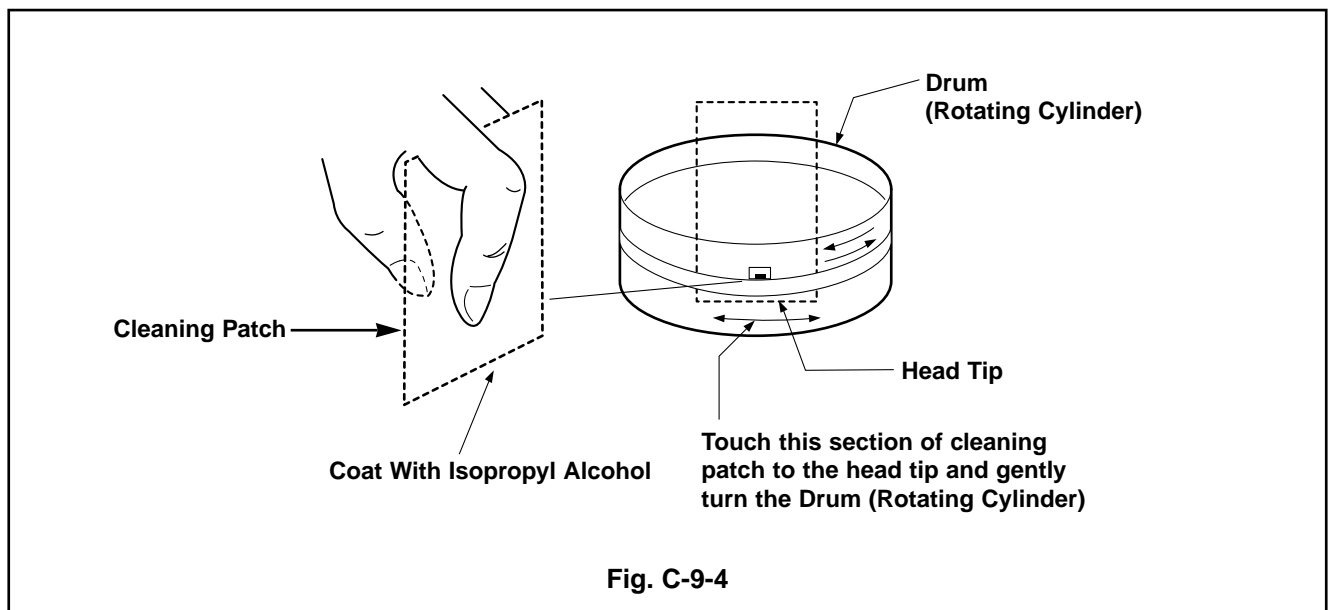

Fig. C-9-4

MAINTENANCE/INSPECTION PROCEDURE

5-2) Greasing

(1) Greasing guidelines

Apply grease, with a cleaning patch. Do not use excessive grease. It may come into contact with the tape transport or drive system. Wipe excessive grease and clean with cleaning patch wetted in Isopropyl Alcohol.

NOTE: Greasing Points

- | | |
|-----------------------------------|---------------------------------------|
| 1) Loading Path Inside & Top side | 5) Arm Take-up Rubbing Sections |
| 2) Base Assembly P2, P3 stopper | 6) Reel S,T shaft(G381:Yellow) |
| 3) Shaft | 7) Arm Assembly F/L Rotating Sections |
| 4) L/D Motor Gear Wheel Part | |

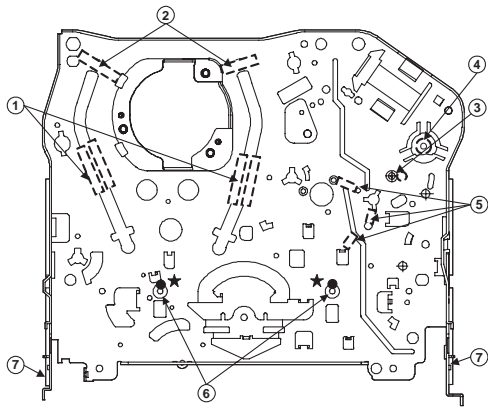

Chassis (Top)

Gear Part

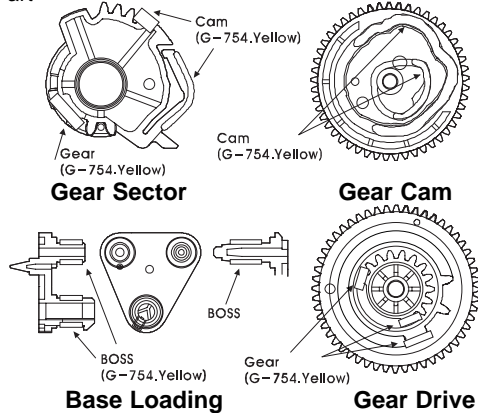

Gear Sector

Gear Cam

Base Loading

Gear Drive

(2) Periodic greasing

Grease specified locations every 5,000 hours.

- | | |
|-----------------------------------|--|
| 1) Loading Path Inside & Top side | 6) Plate Slider Guide Sections |
| 2) Base Assembly P2,P3 stopper | 7) Plate Slider Guide Sections |
| 3) Shaft | 8) Gear Assembly P2, P2 Rubbing Sections |
| 4) Shaft | |
| 5) Clutch Assembly D35 Shaft | |

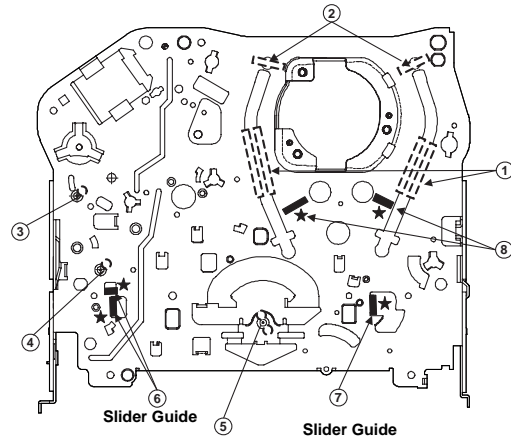

Chassis (Bottom)

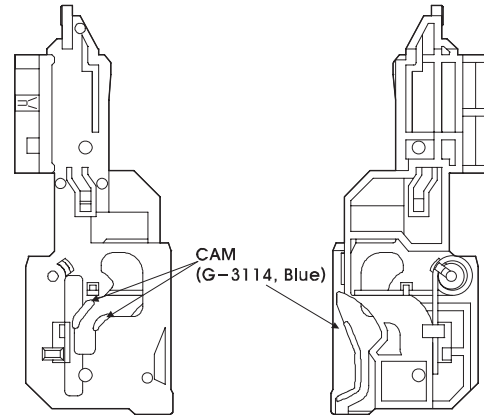

Gear Rack F/L

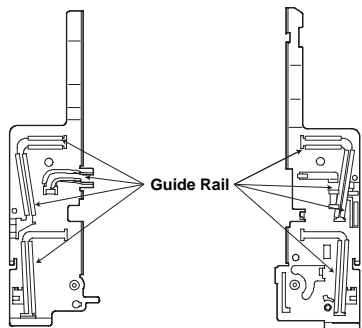

Chassis (Left Side)

Chassis (Right Side)

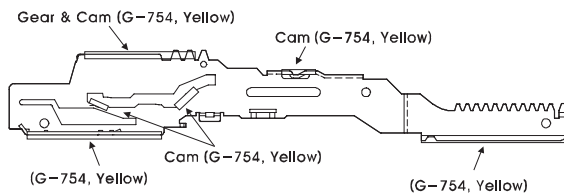
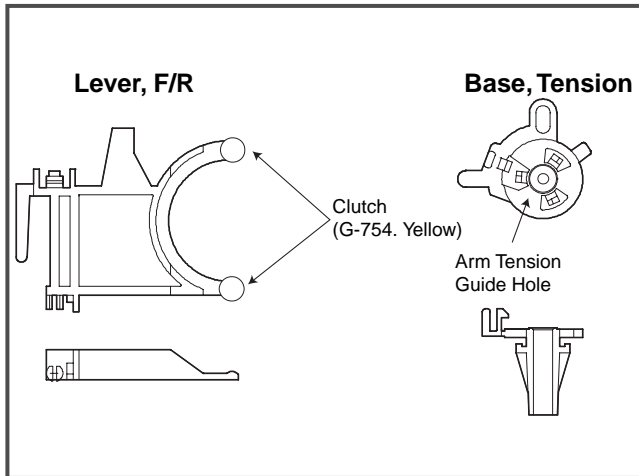

Plate Slider

MAINTENANCE/INSPECTION PROCEDURE

Lever, F/R, Base, Tension



GEAR AY, P2 & P3

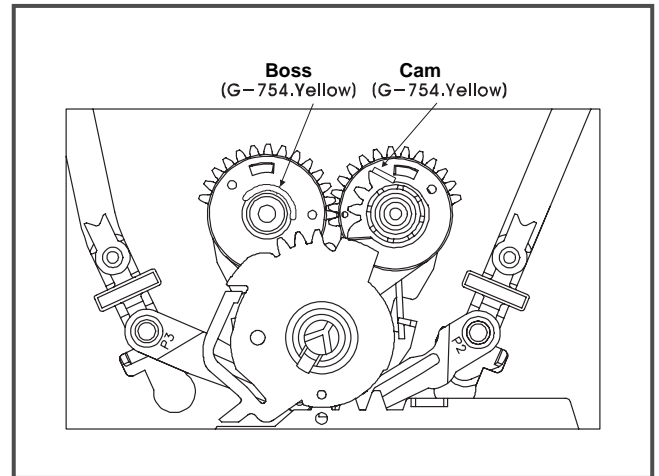

MECHANISM TROUBLESHOOTING GUIDE

1. Deck Mechanism

A.

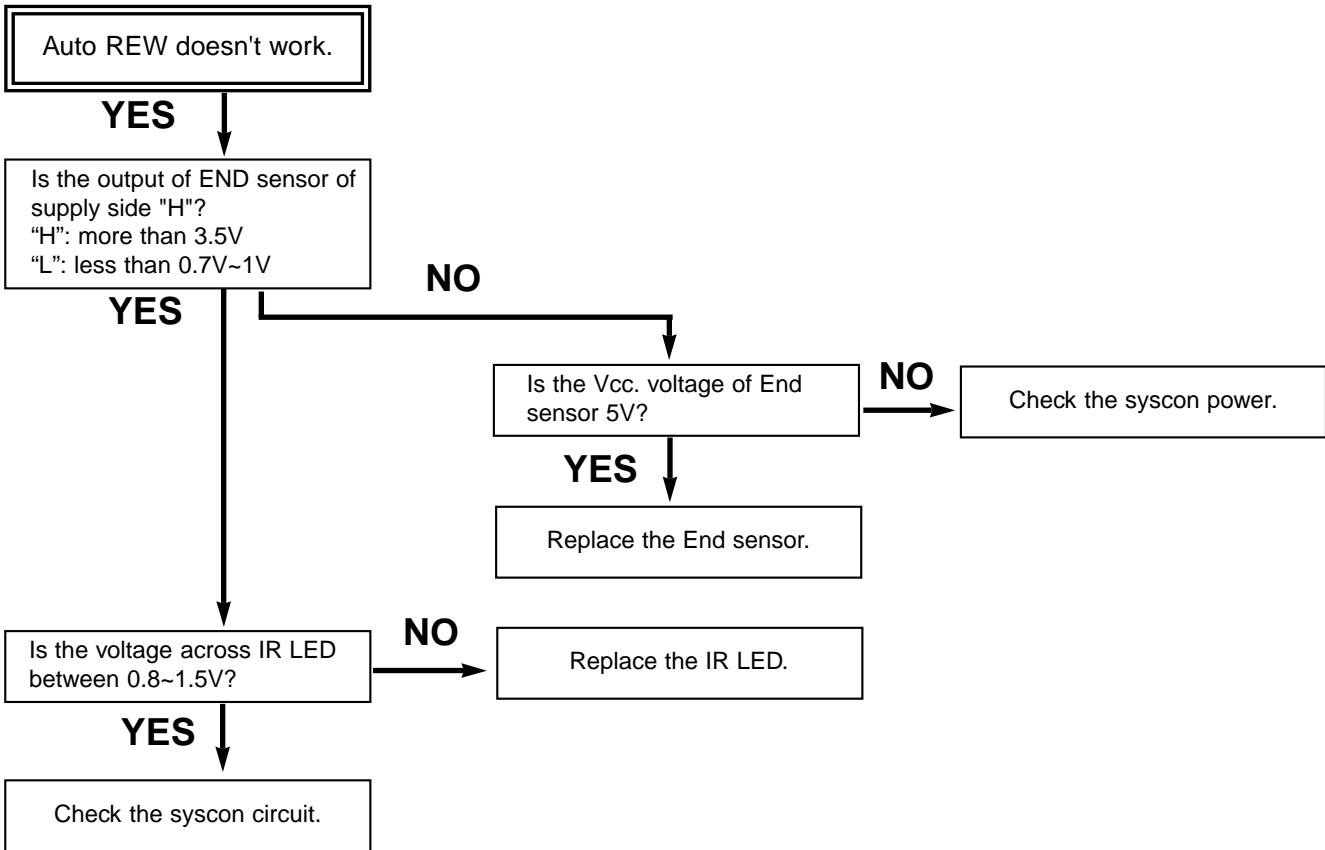

B.

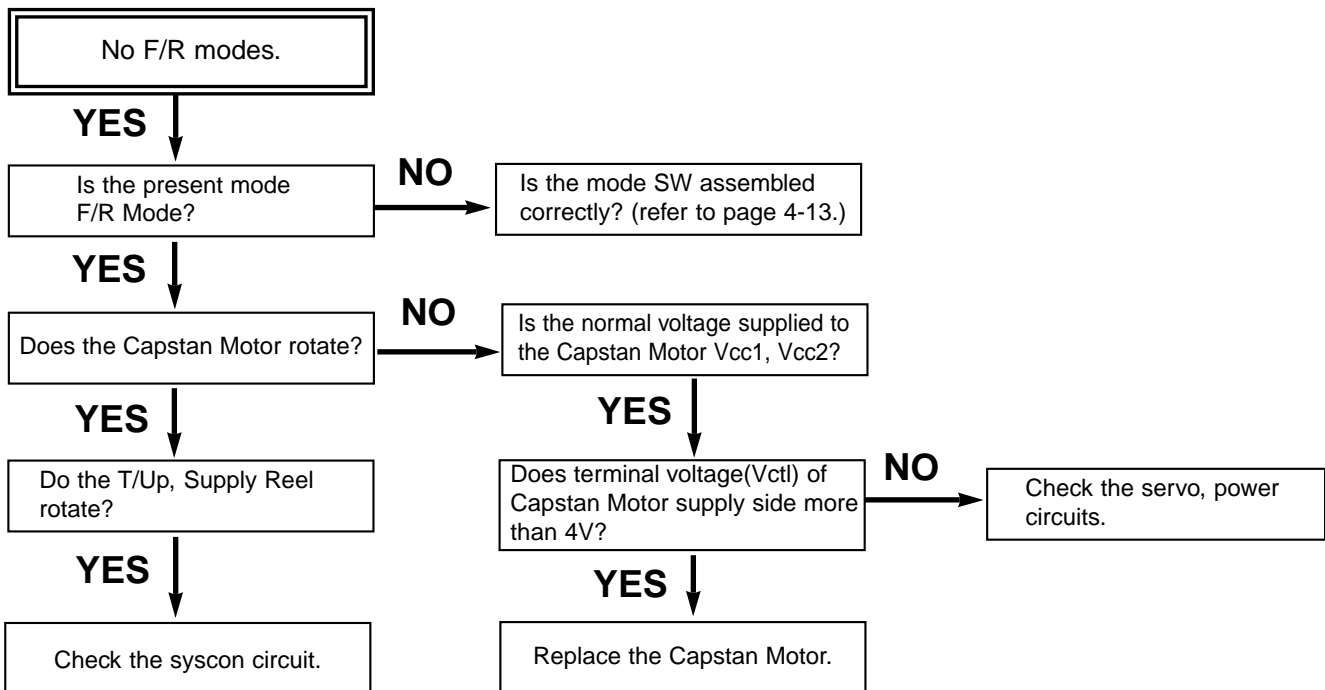

MECHANISM TROUBLESHOOTING GUIDE

C.

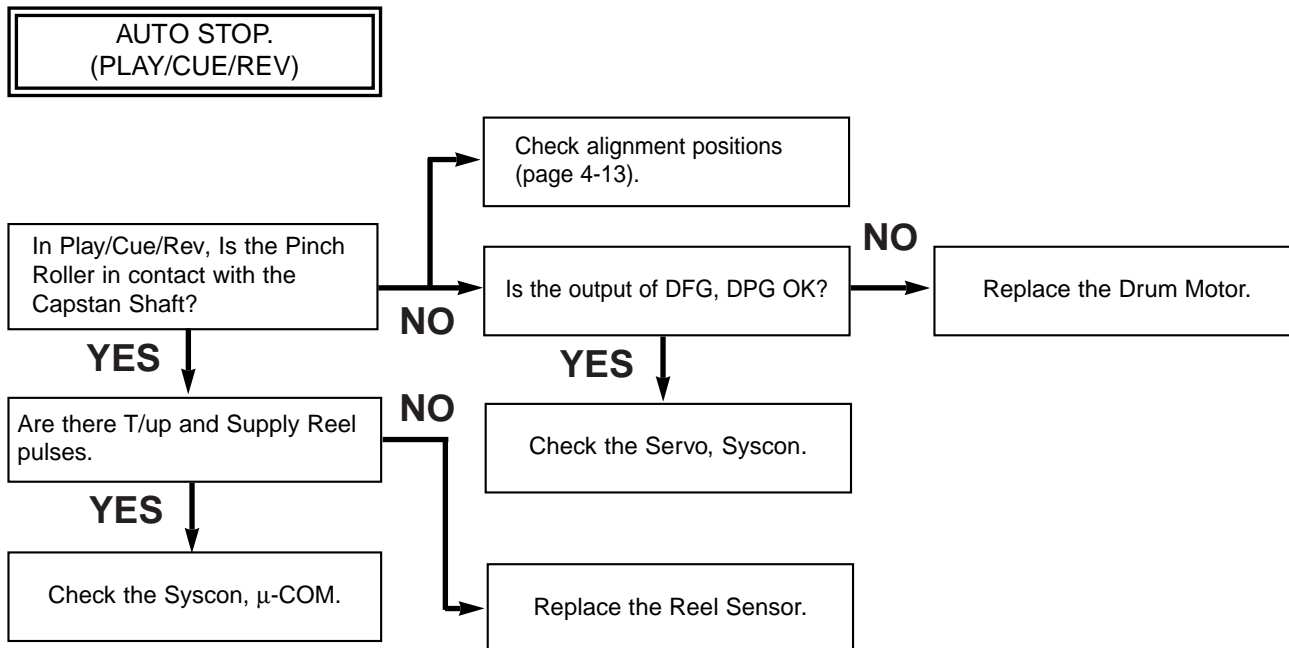

D.

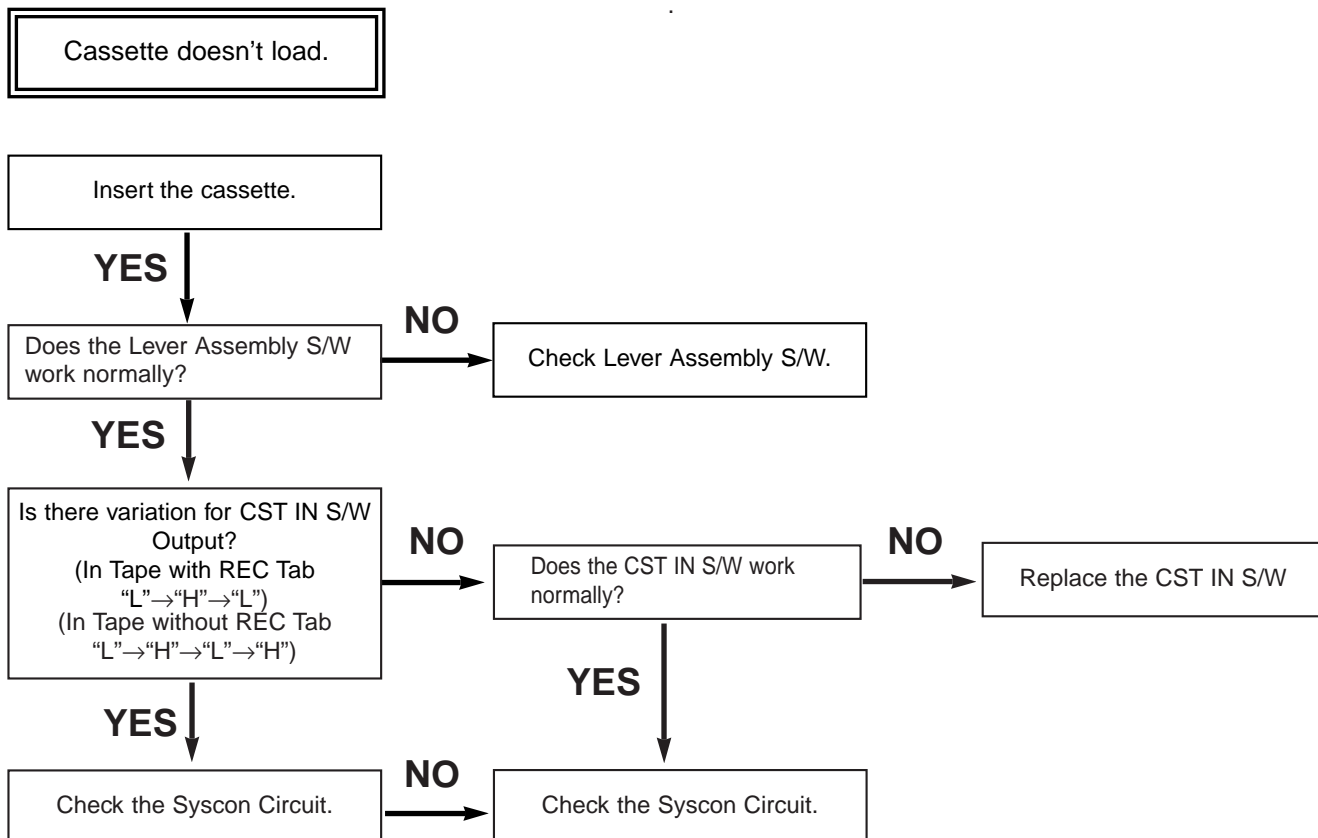

MECHANISM TROUBLESHOOTING GUIDE

E.

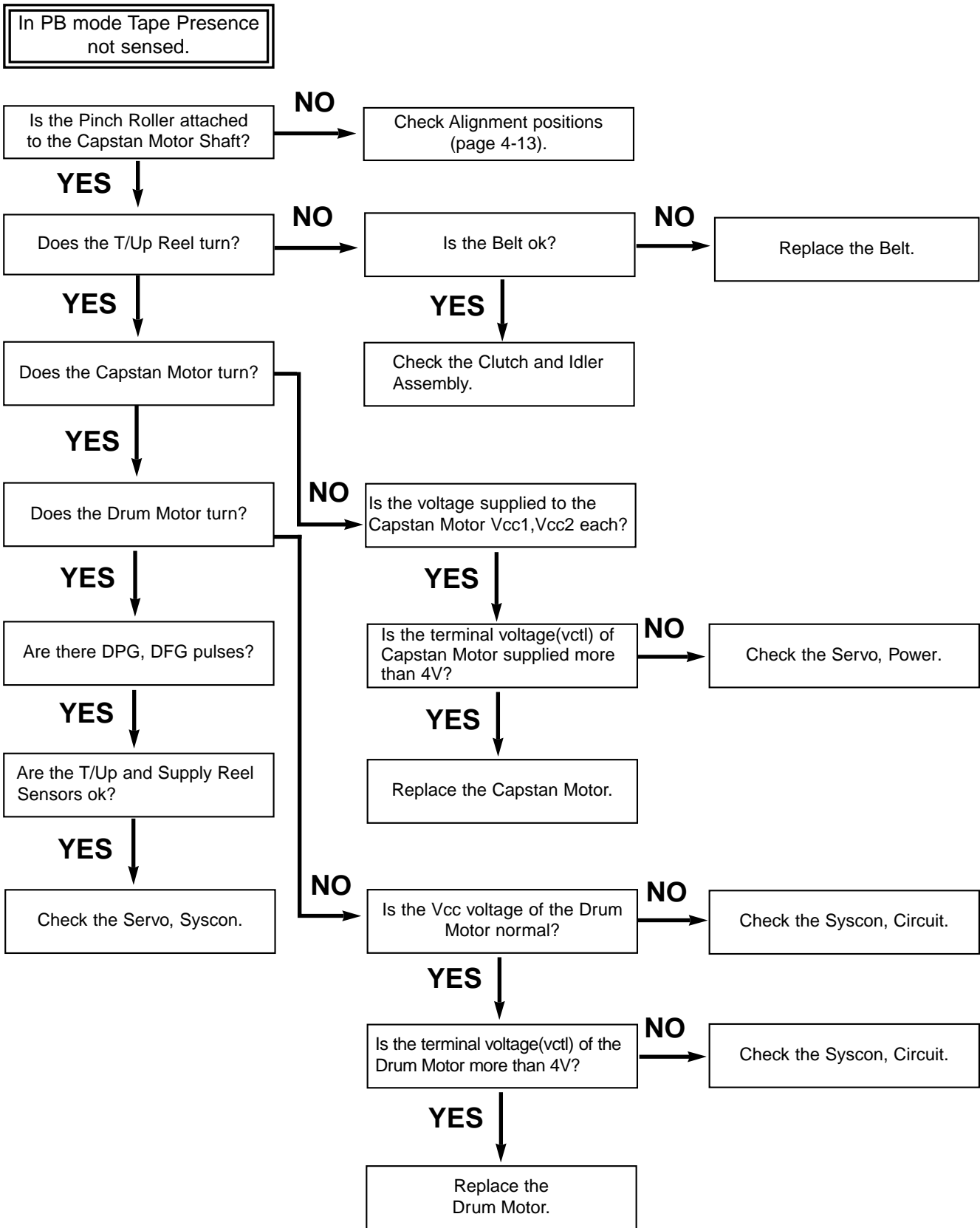

MECHANISM TROUBLESHOOTING GUIDE

2. Front Loading Mechanism

A.

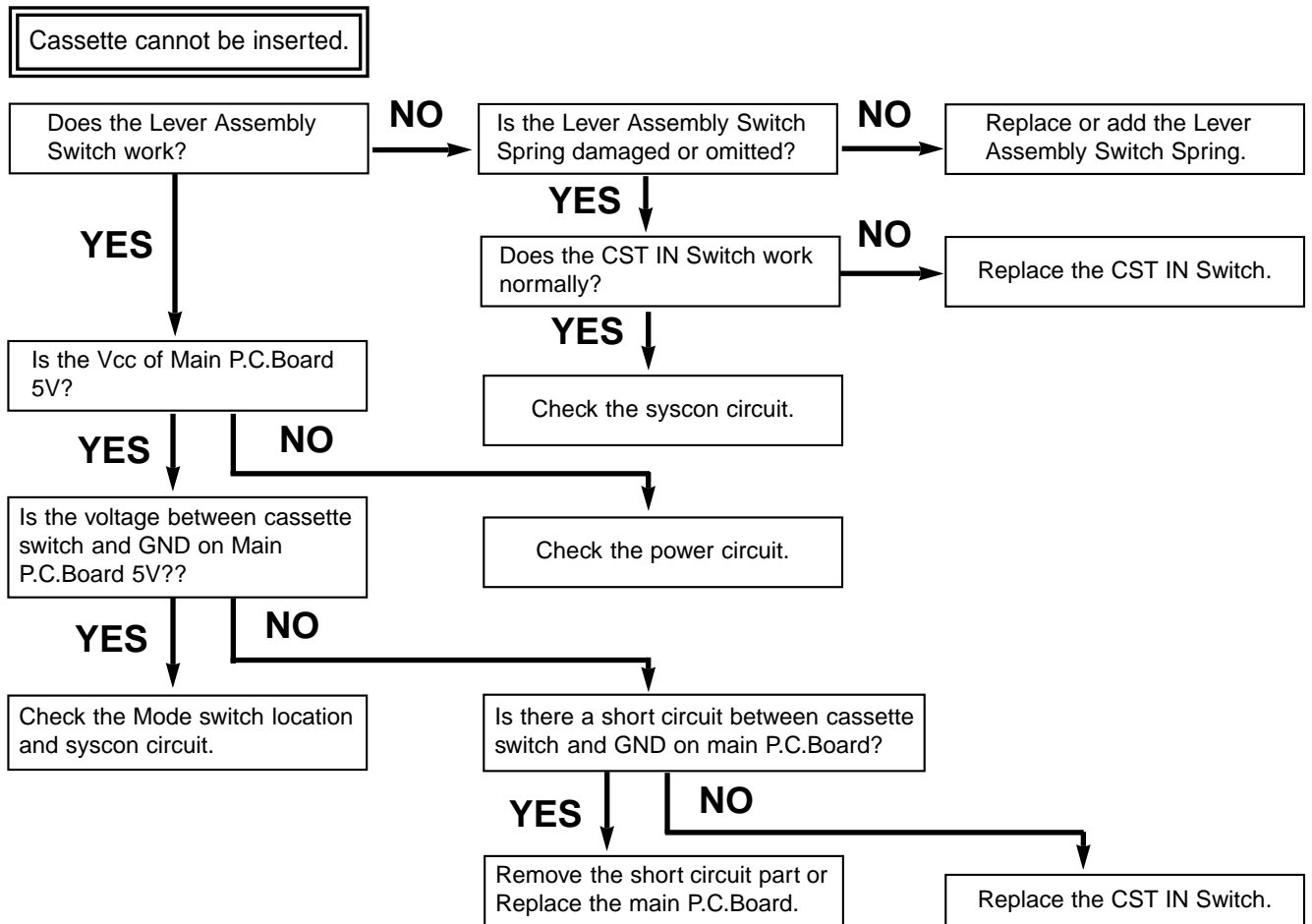

B.

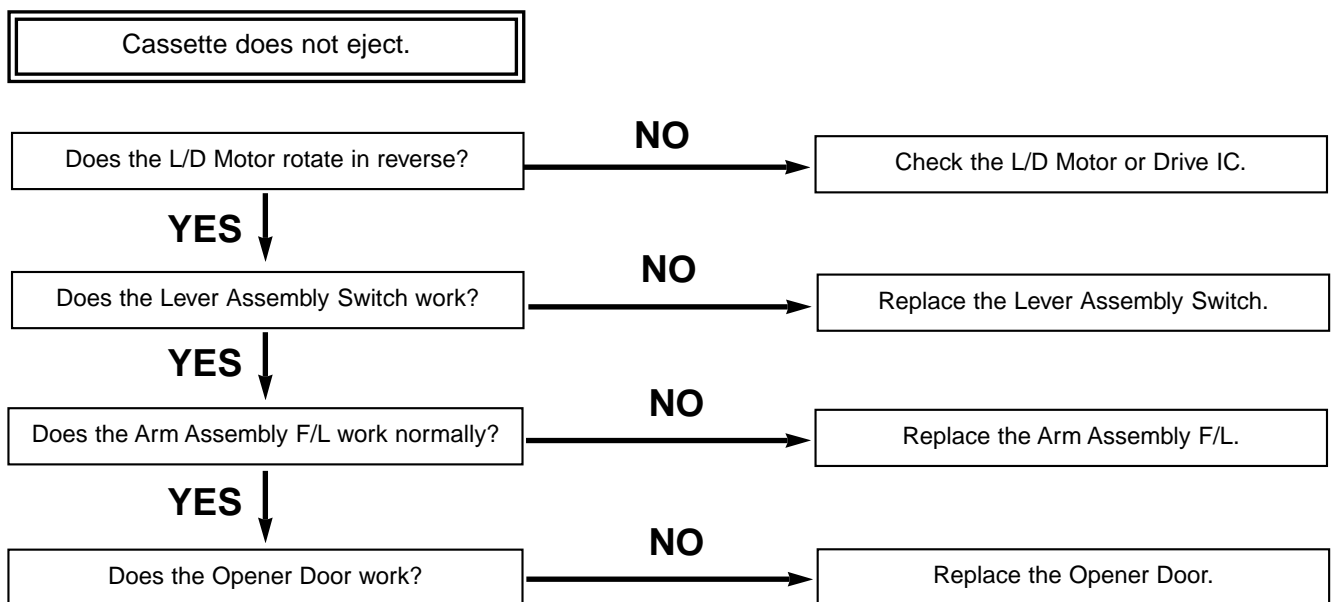

MECHANISM TROUBLESHOOTING GUIDE

C.

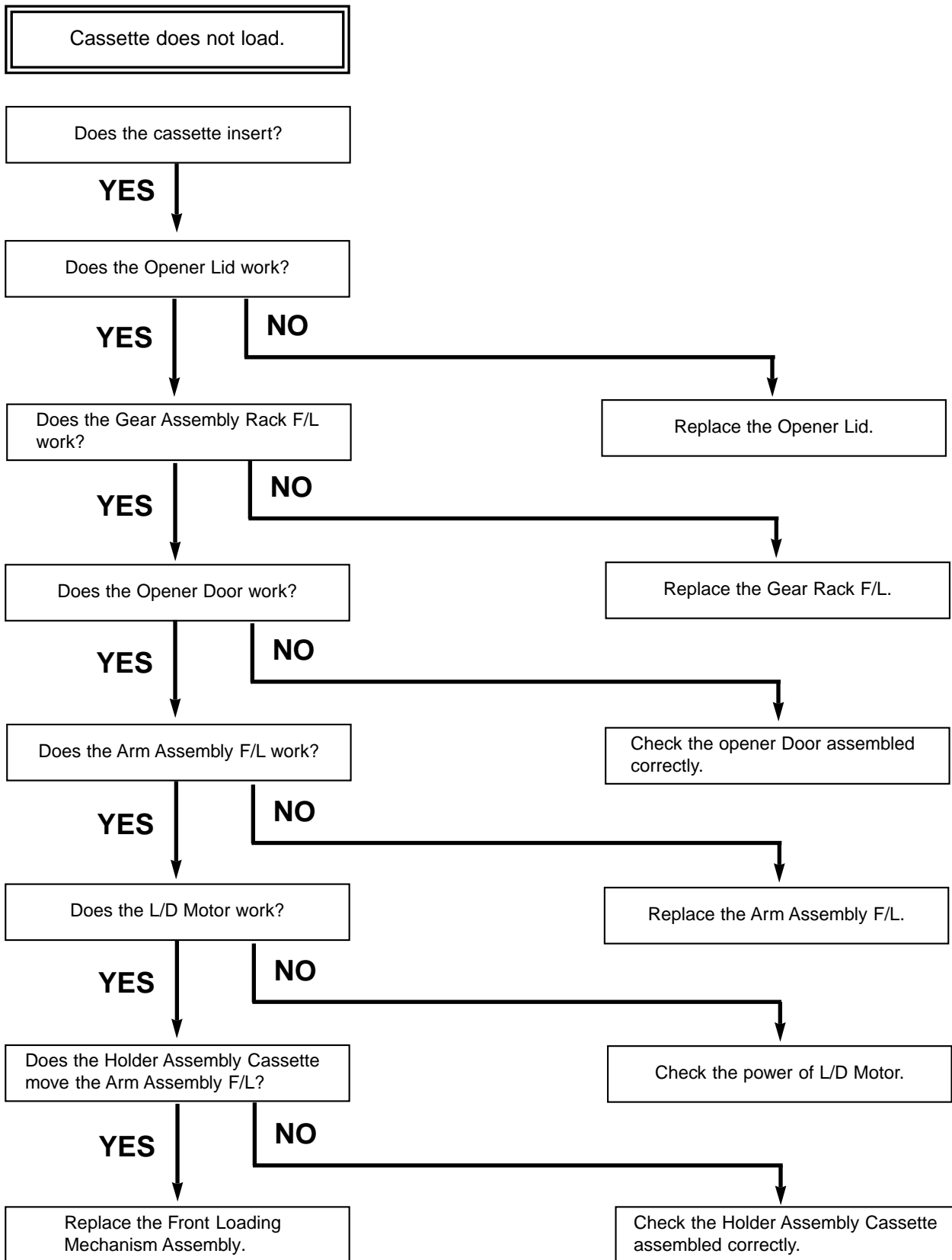

EXPLODED VIEWS

2. Moving Mechanism Section(1)

★ OPTIONAL PART

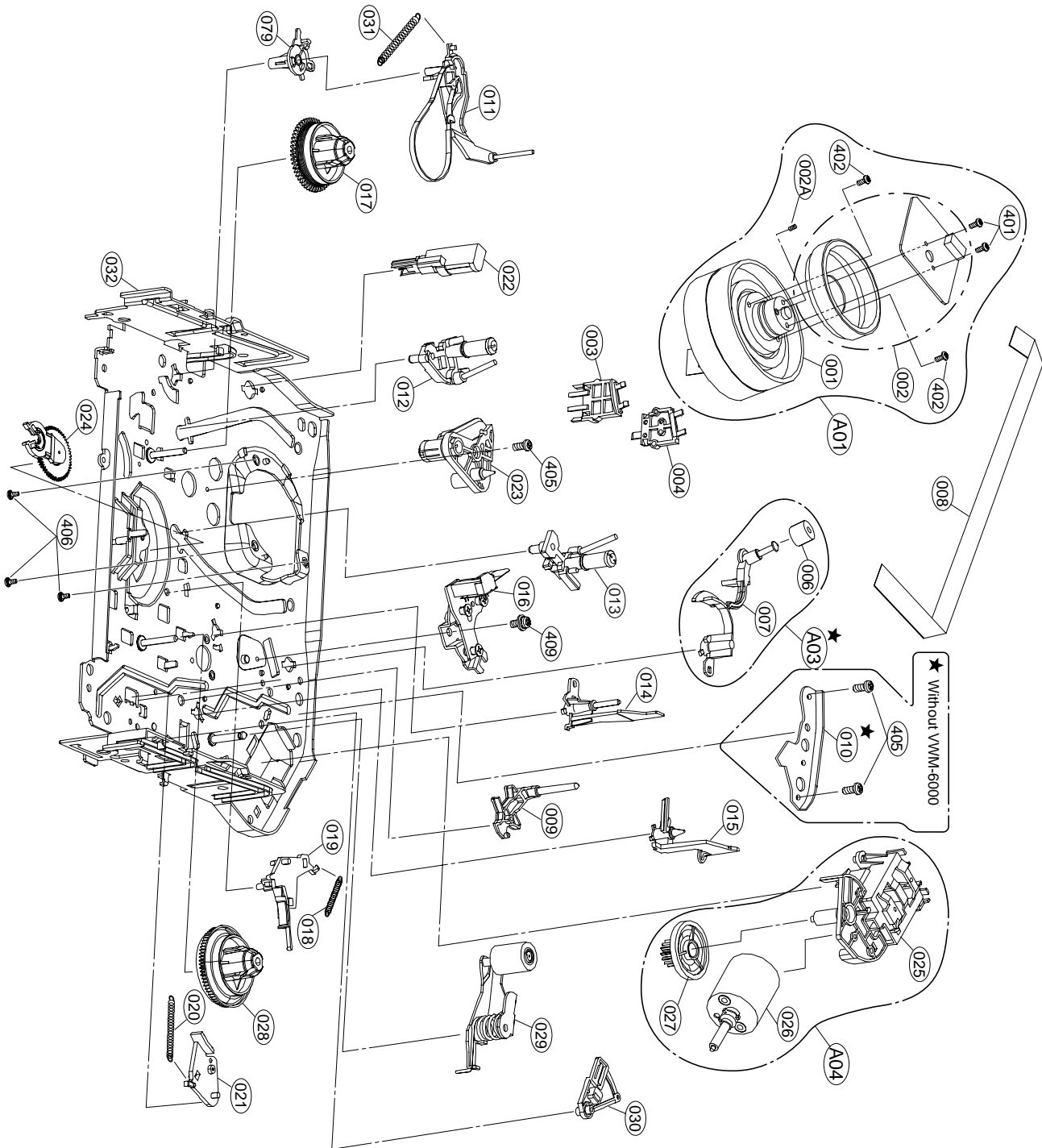

EXPLODED VIEWS

3. Moving Mechanism Section(2)

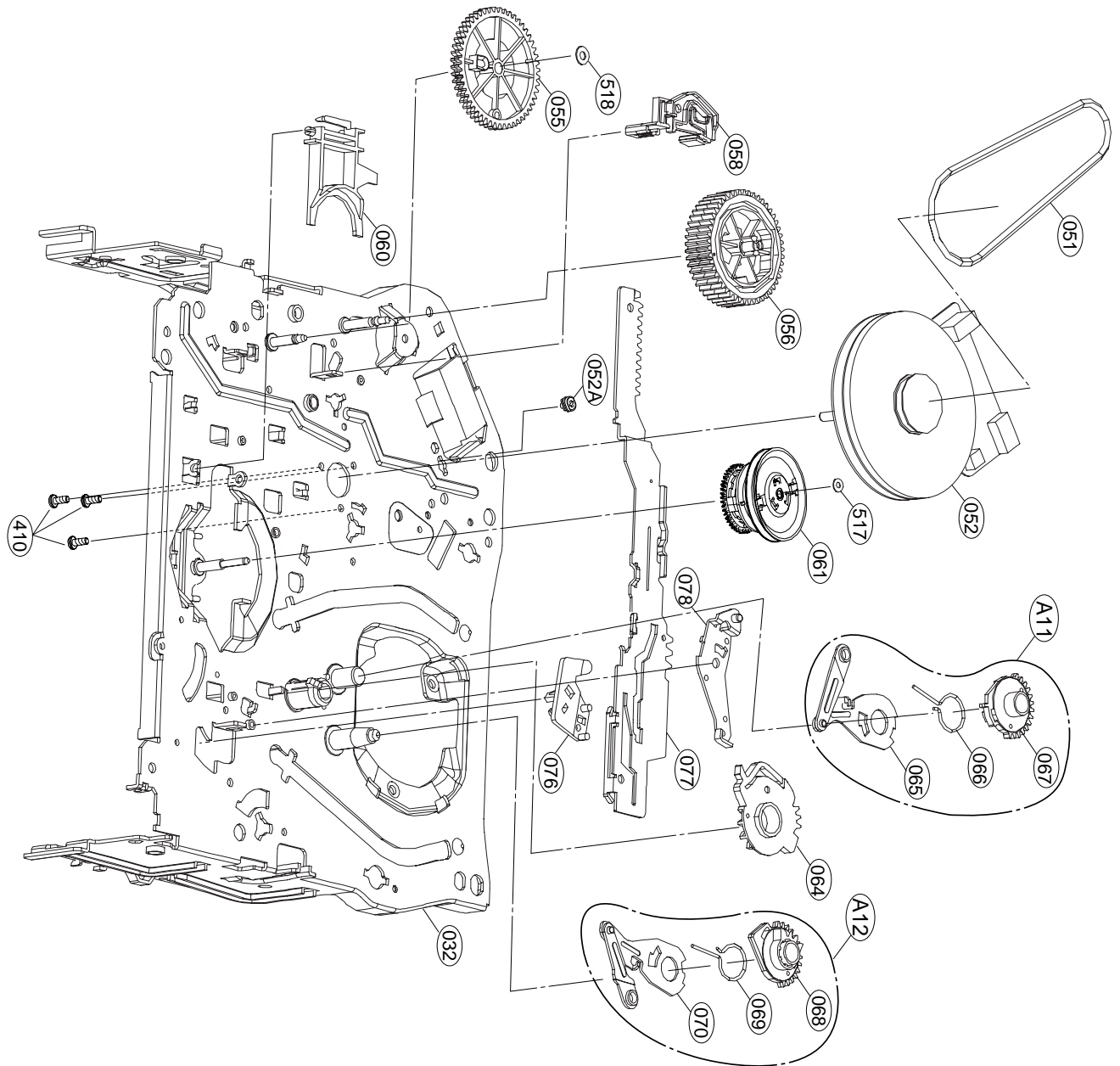

SECTION 5 MECHANISM OF DVD PART

CONTENTS

DECK MECHANISM PARTS LOCATIONS

- Top View.....5-1
- Top View(without Tray Disc)5-1
- Bottom View5-1

DECK MECHANISM DISASSEMBLY

1. Holder Clamp.....5-2
 - 1-1. Clamp Assembly Disc.....5-2
 - 1-1-1. Plate Clamp5-2
 - 1-1-2. Magnet Clamp5-2
 - 1-1-3. Clamp Upper.....5-2
2. Tray Disc5-2
3. Base Assembly Sled5-3
 - 3-1. Gear Assembly Feed5-3
 - 3-2. Gear Assembly Middle.....5-3
 - 3-3. Gear Assembly Rack5-3
4. Rubber Rear.....5-3

5. Frame Assembly Up/Down5-4
6. Belt Loading.....5-4
7. Gear Pulley5-4
8. Gear Loading5-4
9. Guide Up/Down.....5-4
10. PWB Assembly Loading5-4
11. Base Main.....5-4

EXPLODED VIEW

1. Deck Mechanism Exploded View....5-5
-

DECK MECHANISM PARTS LOCATION

• Top View (With Tray)

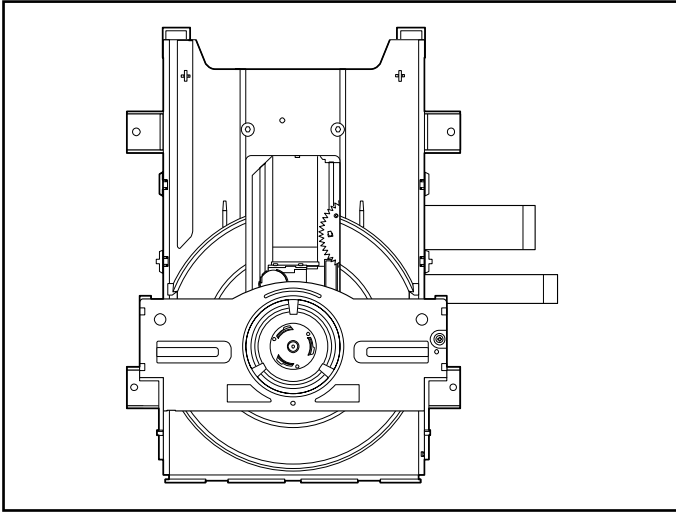

• Top View (Without Tray)

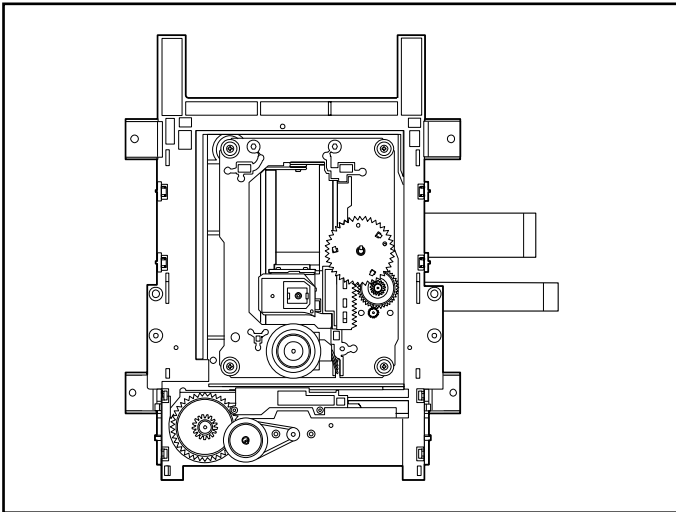

• Bottom View

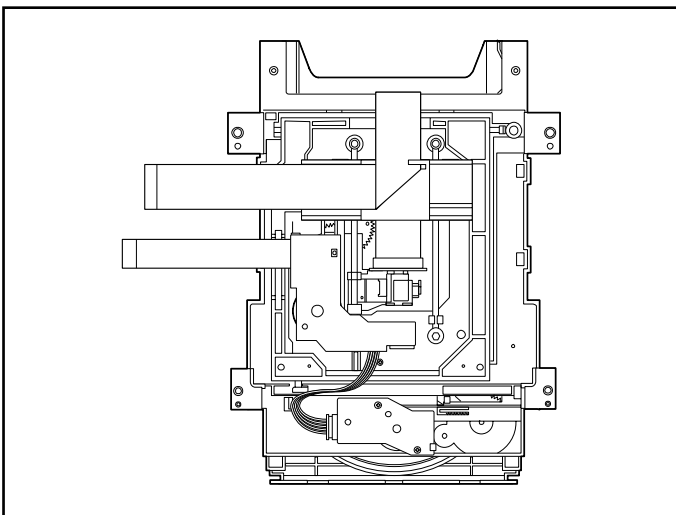

Procedure		Parts	Fixing Type	Disassembly	Figure
Starting No.					
	1	Holder Clamp	2 Screws, 2 Locking Tabs		5-1
1	2	Clamp Assembly Disc			5-1
1, 2	3	Plate Clamp			5-1
1, 2, 3	4	Magnet Clamp			5-1
1, 2, 3, 4	5	Clamp Upper			5-1
1	6	Tray Disc			5-2
1, 6	7	Base Assembly Sled			5-3
1, 2, 6	8	Gear Assembly Feed	4 Screws, 1 Connector 1 Locking Tabs		5-3
1, 2, 6, 8	9	Gear Middle			5-3
1, 2, 6, 8, 9	10	Gear Assembly Rack	1 Screw		5-3
1, 2, 7	11	Rubber Rear			5-3
1, 2, 7	12	Frame Assembly Up/Down	1 Screw	Bottom	5-4
1, 2	13	Belt Loading	1 Locking Tab		5-4
1, 2, 13	14	Gear Pulley			5-4
1, 2, 13, 14	15	Gear Loading	1 Locking Tab		5-4
1, 2, 7, 12, 13, 14	16	Guide Up/Down			5-4
1, 2, 13	17	PWB Assembly Loading	1 Locking Tab 1 Hook 2Screw	Bottom	5-4
1, 2, 7, 12, 13, 14, 15, 16, 17	18	Base Main	2 Locking Tabs		5-4

Note

When reassembling, perform the procedure in reverse order.

The "Bottom" on Disassembly column of above Table indicates the part should be disassembled at the Bottom side.

DECK MECHANISM DISASSEMBLY

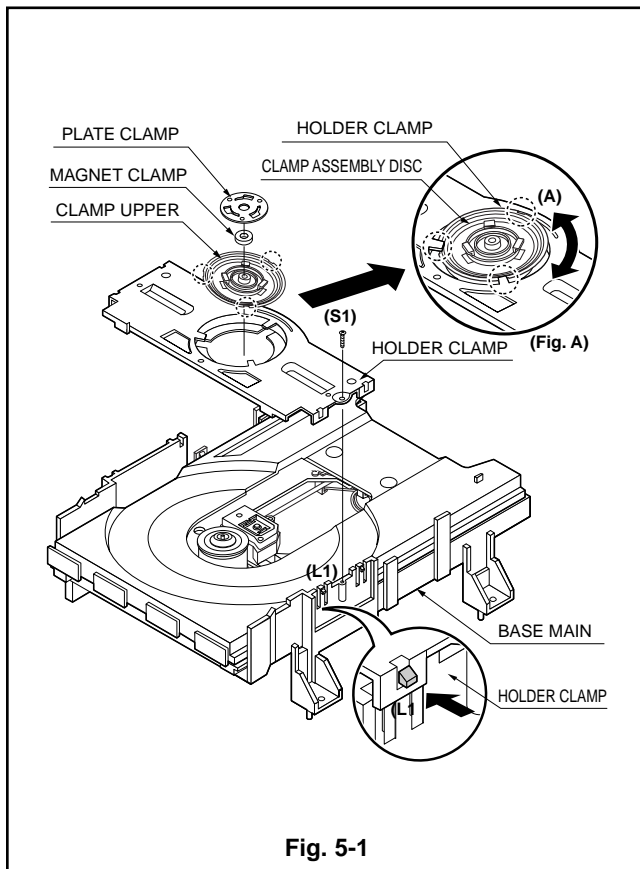

Fig. 5-1

1. Holder Clamp (Fig. 5-1)

- 1) Release 1 Screws(S1).
- 2) Unhook 2 Locking Tabs(L1).
- 3) Lift up the Holder Clamp and then separate it from the Base Main.

1-1. Clamp Assembly Disc

- 1) Place the Clamp Assembly Disc as Fig. (A)
- 2) Lift up the Clamp Assembly Disc in direction of arrow(A).
- 3) Separate the Clamp Assembly Disc from the Holder Clamp.

1-1-1. Plate Clamp

- 1) Turn the Plate Clamp to counterclockwise direction and then lift up the Plate Clamp.

1-1-2. Magnet Clamp

1-1-3. Clamp Upper

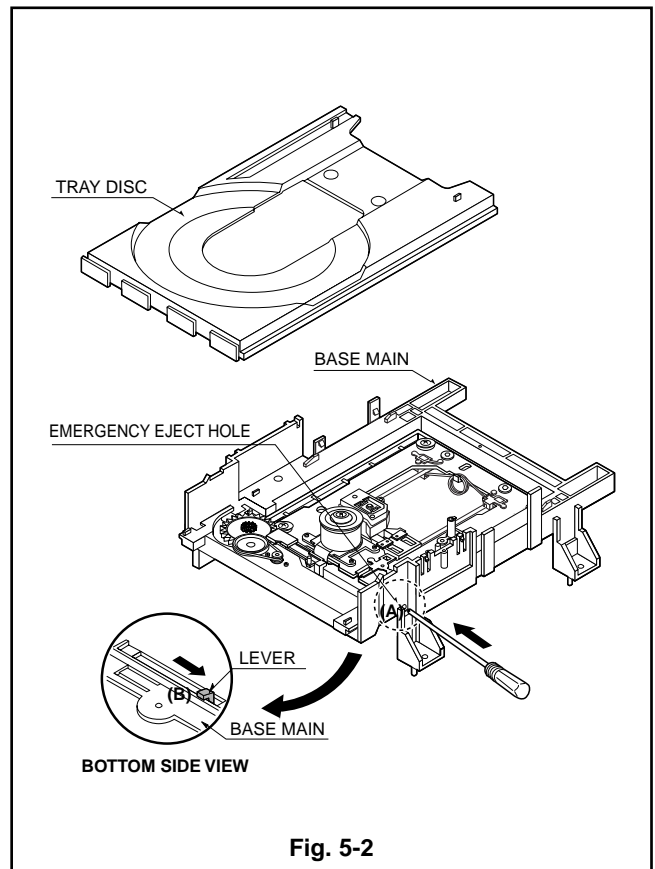

Fig. 5-2

2. Tray Disc (Fig. 5-2)

- 1) Insert and push a Driver in the emergency eject hole(A) at the right side, or put the Driver on the Lever(B) of the Gear Emergency and pull the Lever(B) in direction of arrow so that the Tray Disc is ejected about 15~20mm.
- 2) Pull the Tray Disc until it is separated from the Base Main completely.

DECK MECHANISM DISASSEMBLY

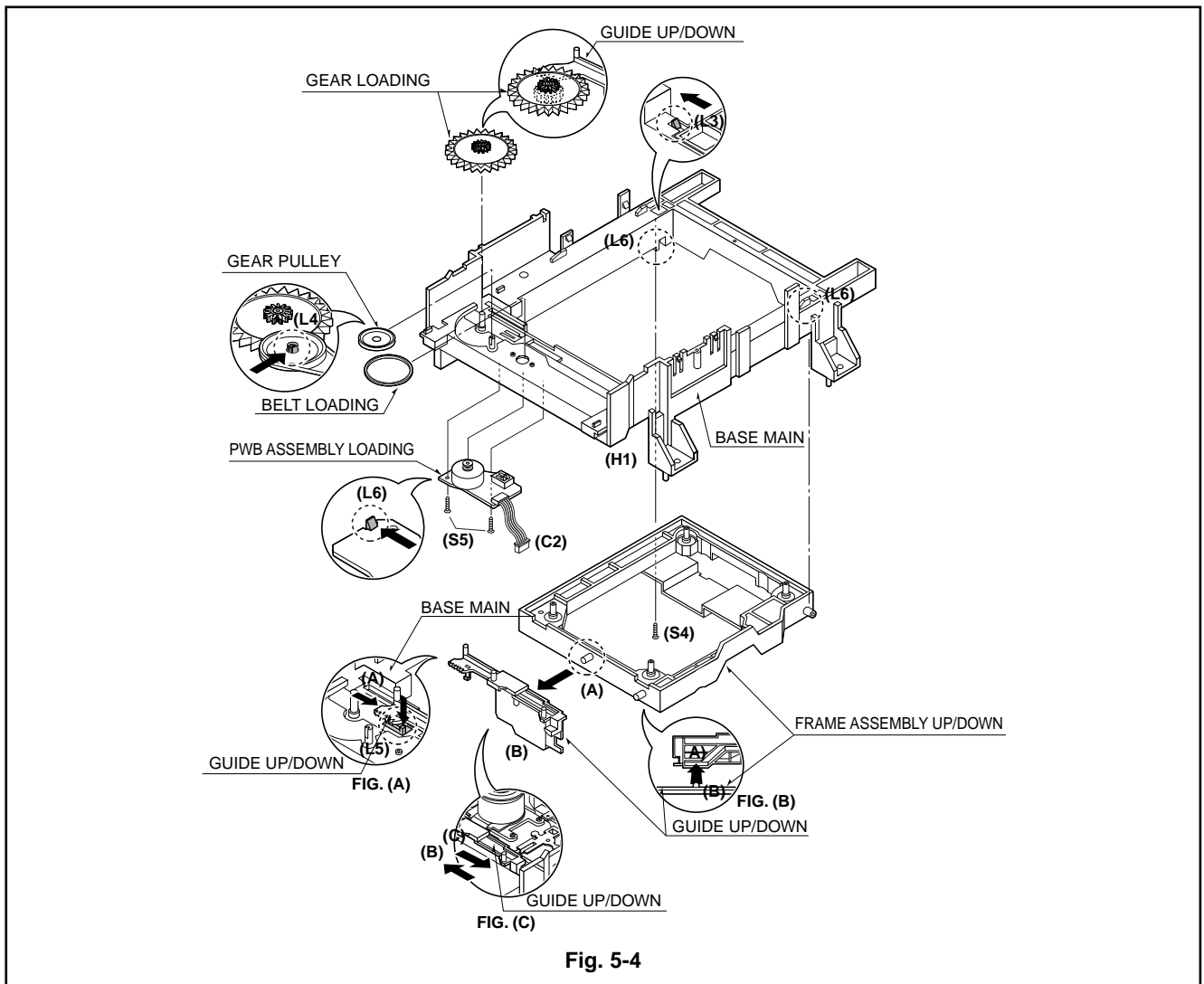

Fig. 5-4

5. Frame Assembly Up/Down (Fig. 5-4)

Note

Put the Base Main face down(Bottom Side)

- 1) Release the Screw(S4)
- 2) Unlock the Locking Tab(L3) in direction of arrow and then lift up the Frame Assembly Up/Down to separate it from the Base Main.

Note

- When reassembling move the Guide Up/Down in direction of arrow(C) until it is positioned as Fig.(C).
- When reassembling insert (A) portion of the Frame Assembly Up/Down in the (B) portion of the Guide Up/Down as Fig.(B)

6. Belt Loading(Fig. 5-4)

Note

Put the Base Main on original position(Top Side)

7. Gear pulley (Fig. 5-4)

- 1) Unlock the Locking Tab(L4) in direction of arrow(B) and then separate the Gear Pulley from the Base Main.

8. Gear Loading (Fig. 5-4)

9. Guide Up/Down (Fig. 5-4)

- 1) Move the Guide Up/Down in direction of arrow(A) as Fig.(A)
- 2) Push the Locking Tab(L5) down and then lift up the Guide Up/Down to separate it from the Base Main.

Note

When reassembling place the Guide Up/Down as Fig.(C) and move it in direction arrow(B) until it is locked by the Locking Tab(L5). And confirm the Guide Up/Down as Fig.(A)

10. PWB Assembly Loading (Fig. 5-4)

Note

Put the Base Main face down(Bottom Side)

- 1) Release 2 Screws(S5)
- 2) Unhook the Loading Motor Connector (C2) from the Hook (H1) on the Base Main.
- 3) Unlock 2 Locking Tabs(L6) and separate the PWB Assembly Loading from the Base Main.

11. Base Main(Fig. 5-4)

EXPLODED VIEWS

1. Deck Mechanism Exploded View

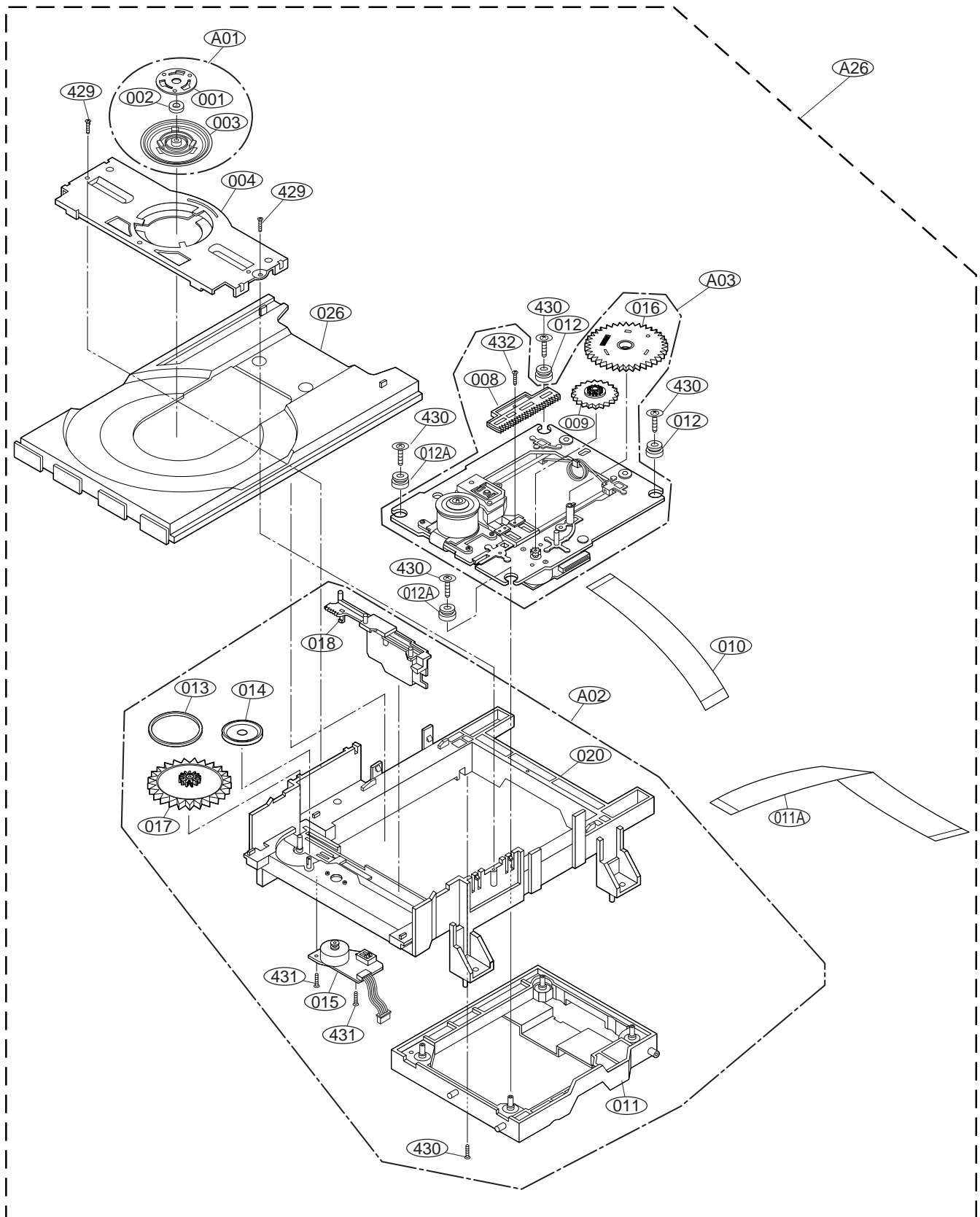

JVC

VICTOR COMPANY OF JAPAN, LIMITED

AV & MULTIMEDIA COMPANY. 12,3-chome,Moriya-cho,Kanagawa-ku,Yokohama,Kanagawa-prefecture,221-8528,Japan



Printed in Japan
0302 VP

JVC



**DVD PLAYER/Hi-Fi STEREO
KARAOKE VIDEO CASSETTE PLAYER**

HR-XV10AG

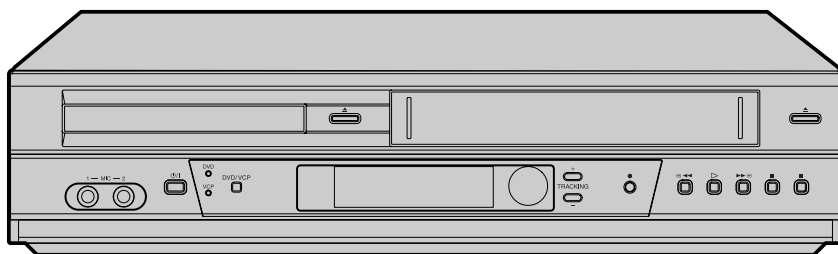

INSTRUCTIONS

LPT0777-001C

EN

Safety Precautions

The rating plate and the safety caution are on the rear of the unit.

WARNING: DANGEROUS VOLTAGE INSIDE
WARNING: TO PREVENT FIRE OR SHOCK HAZARD, DO NOT EXPOSE THIS UNIT TO RAIN OR MOISTURE.

The STANDBY/ON \cup /I button does not completely shut off mains power from the unit, but switches operating current on and off.

This unit is produced to comply with Standard IEC 60065.

When the equipment is installed in a cabinet or a shelf, make sure that it has sufficient space on all sides to allow for ventilation (10 cm or more on both sides, on top and at the rear).

When discarding batteries, environmental problems must be considered and the local rules or laws governing the disposal of these batteries must be followed strictly.

Failure to heed the following precautions may result in damage to the player, remote control or video cassette.

1. **DO NOT** place the player ...
 - ...in an environment prone to extreme temperatures or humidity.
 - ...in direct sunlight.
 - ...in a dusty environment.
 - ...in an environment where strong magnetic fields are generated.
 - ...on a surface that is unstable or subject to vibration.
2. **DO NOT** block the player's ventilation openings or holes.
(If the ventilation openings or holes are blocked by a newspaper or cloth, etc., the heat may not be able to get out.)
3. **DO NOT** place heavy objects on the player or remote control.
4. **DO NOT** place anything which might spill on top of the player or remote control.
(If water or liquid is allowed to enter this equipment, fire or electric shock may be caused.)
5. **DO NOT** expose the apparatus to dripping or splashing.
6. **DO NOT** use this equipment in a bathroom or places with water. Also **DO NOT** place any containers filled with water or liquids (such as cosmetics or medicines, flower vases, potted plants, cups, etc.) on top of this unit.
7. **DO NOT** place any naked flame sources, such as lighted candles, on the apparatus.
8. **AVOID** violent shocks to the player during transport.

Beware of moisture condensation

Moisture in the air will condense on the player when you move it from a cold place to a warm place, or under extremely humid conditions—just as water droplets form on the surface of a glass filled with cold liquid. Moisture condensation on the head drum will cause damage to the tape. In conditions where condensation may occur, keep the player's power turned on for a few hours to let the moisture dry.

When transporting

- Be sure to remove cassette from player before packing.
- Avoid violent shocks to the player during packing and transport.

Video heads cleaning

Accumulation of dirt and other particles on the video heads may cause the playback picture to become blurred or interrupted. Clean the video heads using a dry cleaning cassette or be sure to contact your nearest JVC dealer if such troubles occur.

You can check the video head status by using the Video Doctor function. See page 24.

Usable cassettes

- Compact VHS camcorder recordings can be played on this player. Simply place the recorded cassette into a VHS Cassette Adapter and it can be used just like any full-sized VHS cassette.
- This player can record on regular VHS and Super VHS cassettes. However, it will record and play back regular VHS signals only. It is not possible to play back a recorded Super VHS cassette.

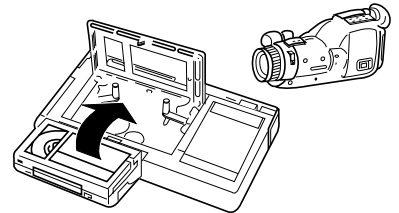

ATTENTION:

To mobile phone users:

Using a mobile phone in the vicinity of the player may cause picture vibration on the screen or change the screen to a blue back display.

On placing the player:

Some TVs or other appliances generates strong magnetic fields. Do not place such appliance on top of the player as it may cause picture disturbance.

CAUTION:

A DVD/VCP IS A CLASS 1 LASER PRODUCT. HOWEVER THIS DVD/VCP USES A VISIBLE LASER BEAM WHICH COULD CAUSE HAZARDOUS RADIATION EXPOSURE IF DIRECTED. BE SURE TO OPERATE THE PLAYER CORRECTLY AS INSTRUCTED.

THE FOLLOWING CAUTION LABEL IS LOCATED ON THE REAR PANEL OF THE DVD/VCP.

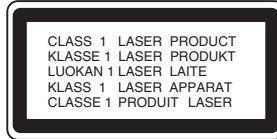

WHEN THIS DVD/VCP IS PLUGGED INTO THE WALL OUTLET, DO NOT PLACE YOUR EYES CLOSE TO THE OPENING OF THE DISC TRAY AND OTHER OPENINGS TO LOOK INTO THE INSIDE OF THIS DVD/VCP.

USE OF CONTROLS OR ADJUSTMENTS OR PERFORMANCE OF PROCEDURES OTHER THAN THOSE SPECIFIED HEREIN MAY RESULT IN HAZARDOUS RADIATION EXPOSURE.

DO NOT OPEN COVERS AND DO NOT REPAIR YOURSELF. REFER SERVICING TO QUALIFIED PERSONNEL.

Contents

Introduction

Safety Precautions	2
Table of Contents	4
Before Use	5-6
Playable Discs	5
Precautions	6
Notes on Discs	6
About Symbols	6
Front Panel and Display Window	7
Remote Control	8-9
Rear Panel	10

Preparation

Connections	11-12
Connecting to a TV	11
Connecting to Optional Equipment	12
Before Operation - VCP part	13
How to using the main menu	13
Before Operation - DVD part	14-17
General Explanation	14
On-Screen Display	14
Initial Settings	15-17
• Initial Settings General Operation	15
• Language	15
• Picture	15
• Sound	16
• Others (DRC/Vocal/PBC)	16
• Parental Control	17

Operation

Operation with tape	18
Playing a tape	18
• CM (Commercial Message) Skip	18
• OPR (Optimum Picture Response)	18
Operation with DVD and Video CD	19-21
Playing a DVD and Video CD	19
General Features	19
• Moving to another TITLE	19
• Moving to another CHAPTER/TRACK	19
• Slow Motion	19
• Still Picture and Frame-by-frame playback	20
• Search	20
• Random	20
• Repeat	20
• Repeat A-B	20
• Time Search	20
• 3D Surround	20
• Zoom	21
• Marker Search	21
Special DVD Features	21
• Title Menu	21
• Disc Menu	21
• Camera Angle	21
• Changing the Audio Language	21
• Subtitles	21

Operation with Audio CD and MP3 Discs	22
Playing an Audio CD and MP3 Discs	22
• Pause	22
• Moving to another Track	22
• Repeat Track/All/Off	22
• Search	22
• Random	22
• Repeat A-B	22
• 3D Surround	22
• Changing the Audio Channel	22
Programmed Playback	23
Programmed Playback with Audio CD and MP3 Discs	23
Programmed Playback with Video CD	23
• Repeat Programmed Tracks	23
• Erasing a Track from Program List	23
• Erasing the Complete Program List	23
Additional Operation - VCP part	24
On Screen Display	24
Tape Counter Memory Stop	24
Video Doctor (Self-Diagnosis)	24
Hi-Fi Stereo Sound System	24
Additional Operation - DVD part	25
Last Condition Memory	25
Screen Saver	25
Video Mode Setting	25
Notes on MP3 Discs	25
Special Operation - Karaoke function	26
Before you start karaoke	26
Karaoke sing-along	26
Grading your singing	26
Special Recording	27
Copying from DVD to VCP	27
Recording from another video player	27

Reference

Troubleshooting	28
Language Code List	29
Country Code List	30
Specification	31



About the symbols for instructions

 Indicates hazards likely to cause harm to the unit itself or other material damage.

 Indicates special operating features of this unit.

 Indicates tips and hints for making the task easier.

Playable Discs

	DVD (8 cm / 12 cm disc)
	Video CD (VCD) (8 cm / 12 cm disc)
	Audio CD (8 cm / 12 cm disc)

In addition, this unit can play a CD-R or CD-RW that contains audio titles or MP3 files.

Notes

- Depending on the conditions of the recording equipment or the CD-R/RW disc itself, some CD-R/RW discs cannot be played on the unit.
- The unit cannot play the CD-R/RW discs that contain no data, or contain different kinds of formatted data other than MP3 and CD-DA data.
- Do not attach any seal or label to either side (the labeled side or the recorded side) of a disc.
- Do not use irregular shaped CDs (e.g., heart-shaped or octagonal). It may result in malfunctions.

Notes on DVDs and Video CDs

Some playback operations of DVDs and Video CDs may be intentionally fixed by software manufacturers. As this unit plays DVDs and Video CDs according to disc content designed by the software manufacturer, some playback features of the unit may not be available, or other functions may be added. Refer also to the instructions applied with the DVDs and Video CDs. Some DVDs made for business purposes may not be played on the unit.

Regional code of the DVD player and DVDs

This DVD player is designed and manufactured for playback of region “2” encoded DVD software. The region code on the labels of some DVD discs indicates which type of player can play those discs. This unit can play only DVD discs labeled “2” or “ALL”. If you try to play any other discs, the message “Check Regional Code” will appear on the TV screen. Some DVD discs may not have a region code label even though their playback is prohibited by area limits.



Disc-related terms

Title (DVD only)

The main film content or accompanying feature content or additional feature content, or music album. Each title is assigned a title reference number enabling you to locate it easily.

Chapter (DVD only)

Sections of a picture or a musical piece that are smaller than titles.

A title is composed of one or several chapters. Each chapter is assigned a chapter number, enable you to locate the chapter you want. Depending on the disc, no chapters may be recorded.

Track (Video CD and audio CD only)

Sections of a picture or a musical piece on a video CD or an audio CD. Each track is assigned a track number, enabling you to locate the track you want.

Scene

On a video CD with PBC (Playback control) functions, moving pictures and still pictures are divided into sections called “Scenes”. Each scene is displayed in the menu screen and assigned a scene number, enabling you to locate the scene you want. A scene is composed of one or several tracks.

Types of video CDs

There are two types of video CDs:

Video CDs equipped with PBC (Version 2.0)

PBC (Playback control) functions allow you to interact with the system via menus, search functions, or other typical computer-like operations. Moreover, still pictures of high resolution can be played if they are included in the disc.

Video CDs not equipped with PBC (Version 1.1)

Operated in the same way as audio CDs, these discs allow playback of video pictures as well as sound, but they are not equipped with PBC.

Before Use (Cont'd)

Precautions

Handling the unit

When shipping the unit

The original shipping carton and packing materials come in handy. For maximum protection, re-pack the unit as it was originally packed at the factory.

When setting the unit

The picture and sound of a nearby TV or radio may be distorted during playback. In this case, position the unit away from the TV or radio, or turn off the unit after removing the disc.

To keep the surface clean

Do not use volatile liquids, such as insecticide spray, near the unit. Do not leave rubber or plastic products in contact with the unit for a long period of time. They will leave marks on the surface.

Cleaning the unit

To clean the cabinet

Use a soft, dry cloth. If the surfaces are extremely dirty, use a soft cloth lightly moistened with a mild detergent solution. Do not use strong solvents, such as alcohol, benzene, or thinner, as these might damage the surface of the unit.

To obtain a clear picture

The DVD player is a high-tech, precision device. If the optical pick-up lens and disc drive parts are dirty or worn down, the picture quality will be poor. Regular inspection and maintenance are recommended after every 1,000 hours of use. (This depends on the operating environment.)
For details, please contact your nearest dealer.

Notes on Discs

Handling discs

Do not touch the playback side of the disc.
Hold the disc by the edges so that fingerprints will not get on the surface.
Do not stick paper or tape on the disc.

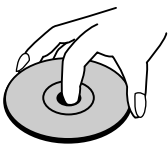

Storing discs

After playing, store the disc in its case.
Do not expose the disc to direct sunlight or sources of heat, or leave it in a parked car exposed to direct sunlight, as there may be a considerable temperature increase inside the car.

Cleaning discs

Fingerprints and dust on the disc can cause poor picture quality and sound distortion. Before playing, clean the disc with a clean cloth. Wipe the disc from the center out.

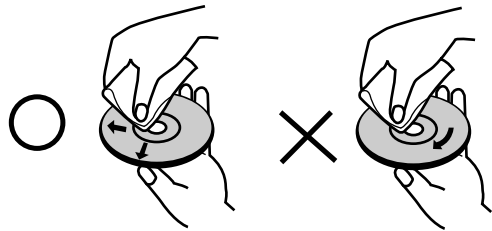

Do not use strong solvents such as alcohol, benzene, thinner, commercially available cleaners, or anti-static spray intended for older vinyl records.

About Symbols

About the symbol display

“” may appear on the TV screen during operation. This icon means the function explained in this owner's manual is not available on that specific DVD video disc.

About the disc symbols for instructions

A section whose title has one of the following symbol is applicable only to the disc represented by the symbol.

 DVD

 Video CDs with the PBC (playback control) function.

 Video CDs without the PBC (playback control) function.

 Audio CDs.

 MP3 disc.

Front Panel and Display Window

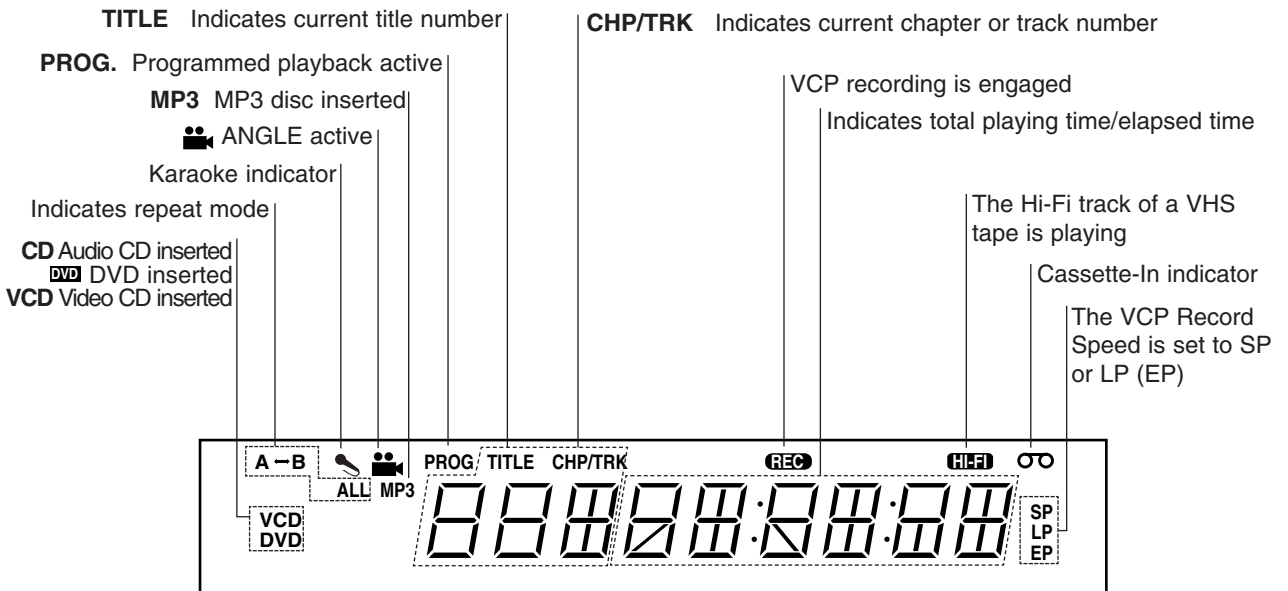
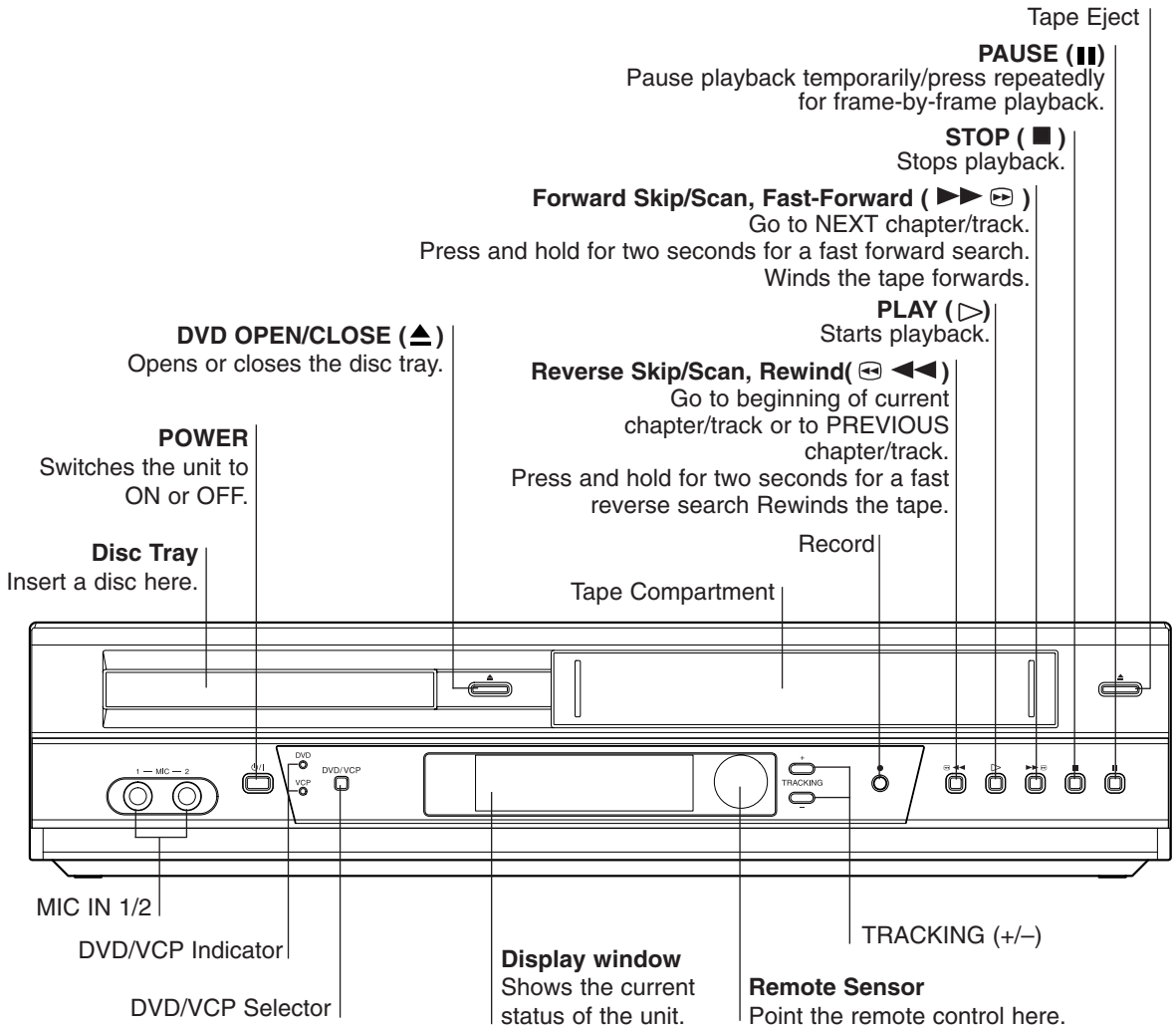

Remote Control

DVD/VCP select button
Selects operational mode of remote control.

POWER
Switch this unit ON or OFF.

DISPLAY COUNT
Access the On-Screen Display.
Shows you the counter.

◀ ▶ ▲ ▼ (left/right/up/down)
- Select an item in the menu
- Perform the Karaoke Search.

SETUP/ MENU
Access or remove setup menu.

TITLE •
Display the title menu of the disc if available.

PAUSE/STEP (II) •
Pause playback temporarily / press repeatedly for frame-by-frame playback.

STOP (■) •
Stops playback.

0-9 numerical buttons
Select numbered items in a menu.

A. MONITOR •
Select an audio language (DVD) or an audio channel (CD).

SUBTITLE •
Select a subtitle language.

MARKER •
Mark any point during playback.

SEARCH •
Display MEMORY SEARCH menu.

MIC/ECHO •
To select the MIC/ECHO mode

RETURN •
- Remove the setup menu.
- Displays the menu of a video CD with PBC.

KARAOKE
Switch Karaoke on and off.

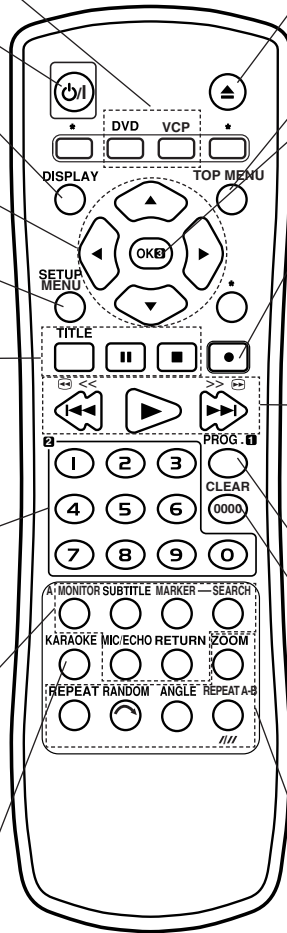

OPEN/CLOSE EJECT
- Open or close the disc tray.
- Tape Eject.

TOP MENU
Access menu of a DVD disc.

SELECT/ENTER/OK
Acknowledge menu selection.

REC
Record your input sources into tape.

• Forward SKIP/SCAN (▶▶I) / Fast - Forward
- Search forward* / go to next chapter or track.
- Winds the tape forwards.

❖ Press and hold button for about two seconds.

• PLAY (▶)
Starts playback.

• Reverse SKIP/SCAN (I◀◀) / Rewind
- Search backward* / go to beginning of current chapter or track or go to previous chapter or track.
- Rewinds the tape.

❖ Press and hold button for about two seconds.

PROGRAM
Access or remove program menu.

CLEAR
- Clear a track number on the program menu or a mark on the MARKER SEARCH menu.
- Reset tape counter to zero.

• REPEAT
- Repeat chapter, track, title, all.

• RANDOM
- Play tracks in random order.
- CM Skip

• ANGLE
Select DVD camera angle if available

• REPEAT A-B/LP
- Repeat sequence.
- Select the recording speed of the tape.

• ZOOM
Enlarge video image.

* Feature is not available.

Remote Control (Cont'd)

Remote Control Operation Range

Point the remote control at the remote sensor and press the buttons.

- **Distance:** About 7 m from the front of the remote sensor
- **Angle:** About 30° in each direction of the front of the remote sensor

Remote control battery installation

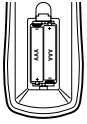

Detach the battery cover on the rear of the remote control, and insert two R03 (size AAA) batteries with \oplus and \ominus aligned correctly.

Caution

Do not mix old and new batteries. Never mix different types of batteries (standard, alkaline, etc.).

Remote A/B Code Switching

The remote control is capable of controlling two JVC units independently; one set to respond to the remote control's A code control signals and another set to respond to B code control signals. The remote control is preset to send A code signals because your unit is initially set to respond to A code signals. You can easily change your unit to respond to B code signals.

- 1** Press and hold **VCP** on the remote control for over 2 seconds, press the **number key "2"** and then press **OK**. The remote control now can transmit B code signals.
- 2** Press and hold **PLAY ►** on the unit for more than 5 seconds while the unit is turned off. The code currently set appears on the display window.
- 3** Press any key on the remote control. The unit will now only respond to B code signals.

Notes

- To set the unit back to respond to A code signals, repeat the same procedure as shown above, but in step **1**, press the **number key "1"** instead of "2".
- The code for the unit will be back to respond A code signals once you disconnect the AC power cord.

Rear Panel

AUDIO OUT (Left/Right)

Connect to an amplifier, receiver or stereo system.

COAXIAL (Digital audio out jack)

Connect to digital (coaxial) audio equipment.

AUDIO OUT L/R (Both DVD and VHS out)

Connect to an amplifier, receiver or stereo system.

AUDIO IN L/R (VHS IN)

Receive the audio signals from an external source to VCP.

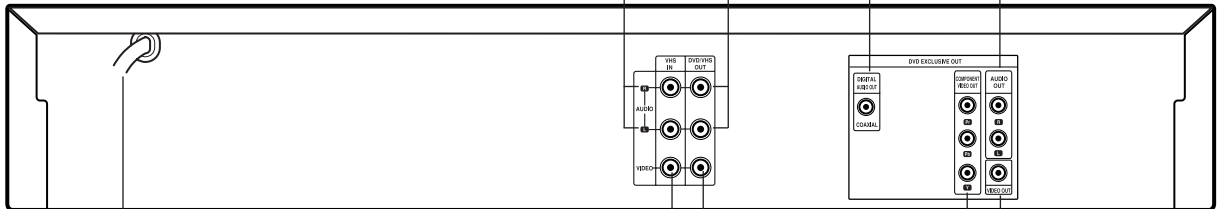

AC Power Cord

Connect to a power source.

VIDEO IN (VHS IN)

Receive the video signals from an external source to VCP.

VIDEO OUT (Both DVD and VHS out)

Connect to a TV with video inputs.

COMPONENT VIDEO OUT (Y Pb Pr) (DVD OUT)

Connect to a TV with Y Pb Pr inputs.

VIDEO OUT

Connect to a TV with video inputs.



Do not touch the inner pins of the jacks on the rear panel. Electrostatic discharge may cause permanent damage to the unit.

Connections

Tips

- Depending on your TV and other equipment you wish to connect, there are various ways you could connect the unit.
- Please refer to the manuals of your TV, Stereo System or other devices as necessary to make the best connections.
- For better sound reproduction, connect this unit's AUDIO OUT jacks to the audio in jacks of your amplifier, receiver, stereo or audio/video equipment. See "Connecting to optional equipment" on page 12.

Caution

- Make sure this unit is connected directly to the TV. Set the TV to the correct video input channel.
- Do not connect this unit's AUDIO OUT jack to the phono in jack (record deck) of your audio system.

Connecting to a TV

- Make one of the following connections, depending on the capabilities of your existing equipment.
- When using the COMPONENT VIDEO OUT jacks, set TV's INPUT to COMPONENT VIDEO.

Basic connection (AV)

- 1 Connect the VIDEO OUT jack on this unit's DVD/VHS OUT to the video in jack on the TV using the video cable supplied.
- 2 Connect the Left and Right AUDIO OUT jacks of this unit's DVD/VHS OUT to the audio left/right in jacks on the TV using the supplied audio cables.

Component Video (Color Stream®) connection (for DVD)

- 1 Connect the COMPONENT VIDEO OUT jacks on the unit to the corresponding in jacks on the TV using an optional Y Pb Pr cable.
- 2 Connect the Left and Right AUDIO OUT jacks of the unit to the audio left/right in jacks on the TV using the audio cables.

DVD exclusive out connection

- You can only watch the DVD playback.

- 1 Connect the VIDEO OUT jack on this unit's DVD EXCLUSIVE OUT to the video in jack on the TV using the video cable.
- 2 Connect the Left and Right AUDIO OUT jacks of this unit's DVD EXCLUSIVE OUT to the audio left/right in jacks on the TV using the audio cables.

Rear of this unit (DVD exclusive out connection)

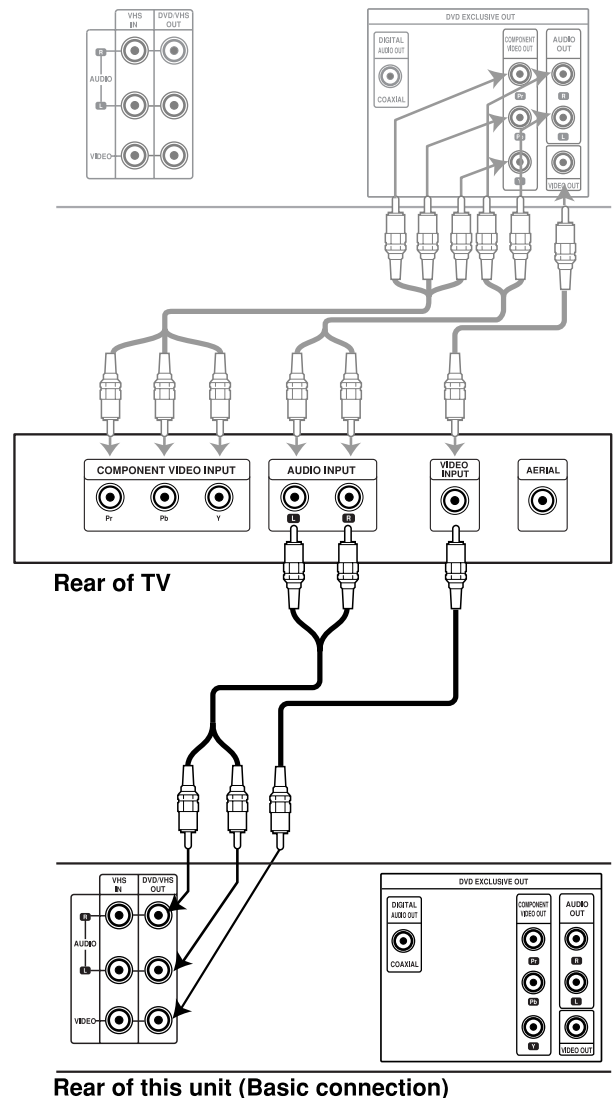

Rear of this unit (Basic connection)

Connecting to Optional Equipment

Connecting to an amplifier equipped with two channel analog stereo or Dolby Surround

Connect the Left and Right AUDIO OUT jacks on this unit to the audio left and right in jacks on your amplifier, receiver or stereo system, using the audio cables.

Connecting to an amplifier equipped with two channel digital stereo (PCM) or to an Audio/Video receiver equipped with a multi-channel decoder (Dolby Digital™, MPEG 2 or DTS)

- 1 Connect this unit's DIGITAL AUDIO OUT jack (COAXIAL) to the corresponding in jack on your amplifier. Use an optional coaxial audio cable.
- 2 You will need to activate this unit's digital output. (See "Digital Audio Output" on page 16).

Digital Multi-channel sound

A digital multi-channel connection provides the best sound quality. For this you need a multi-channel Audio/Video receiver that supports one or more of the audio formats supported by your unit (MPEG 2, Dolby Digital and DTS). Check the receiver manual and the logos on the front of the receiver.

Warning:

Due to the DTS Licensing agreement, the digital output will be in DTS digital out when DTS audio stream is selected.

Notes

- If the audio format of the digital output does not match the capabilities of your receiver, the receiver will produce a strong, distorted sound or no sound at all.
- To see the audio format of the current DVD in the On-Screen Display, press **A. MONITOR**.

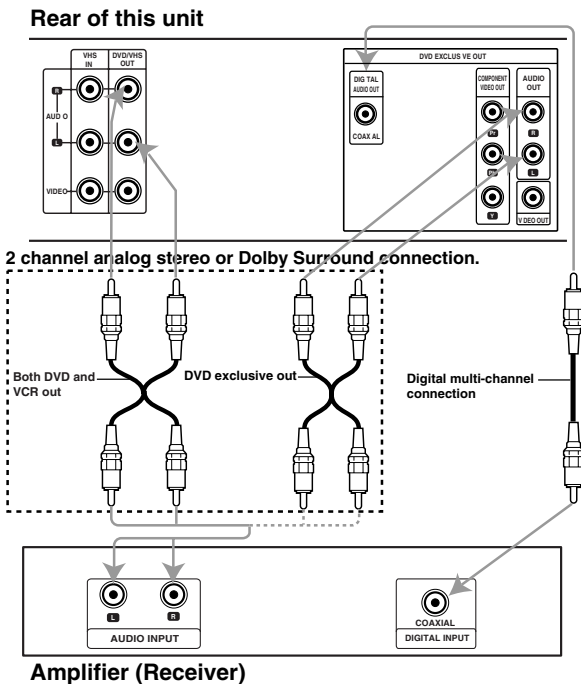

Before Operation - VCP part

How to using the main menu

This VCP can easily be programmed by using the menus displayed on screen. The menus are controlled from the Remote Control Handset.

- 1** Switch on your TV set and video player by pressing ψ/I .
- 2** Press **VCP**.
- 3** Press **MENU**.
The main menu will appear on the TV screen.

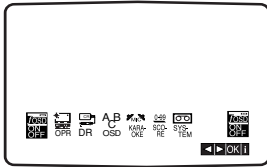

- **F.OSD ON/OFF** - To switch the display of operational mode of your VCP ON or OFF (see p 24).
- **OPR** - To improve the playback picture (see p 18).
- **DR** - To check a problem with your VCP (see p 24).
- **ABC OSD** - To change the language setting for OSD.
You can select the language between English and Russian.
- **KARAOKE** - To switch on or off Karaoke & Karaoke Search (see p 26).
- **SCORE** - To display the score your song when you Karaoke (see p 26).
- **SYSTEM** - Select the colour system used for playback and recording.
The system is changed as shown below. (Refer to the right for more information.)
*If you want to record NTSC signals, press **OK** and select between NTSC 3.58 and NTSC 4.43.

Source	Mode	System Change
PAL/ MESECAM	Recording	AUTO → PAL → MESECAM
	Playback	AUTO → PAL → MESECAM
NTSC	Recording	NTSC3.58 → NTSC4.43*
	Playback	NTSC-PB → NTSC3.58 → NTSC4.43

- 4** Press \blacktriangleleft and \blacktriangleright to select the option to change, then Press **OK** to change the setting and press \blacktriangleleft and \blacktriangleright to select the sub menu.
- 5** Press **MENU** to remove the menu screen.

To set the colour system

If streaks appear during playback, set colour system manually to conform to the system that the tape was recorded in. (Normally set the switch to AUTO.)

If your tape was recorded in	Set colour system to	If your TV is
PAL	PAL	
NTSC3.58	NTSC3.58	MULTI-SYSTEM TV
	NTSC-PB	PAL TV
NTSC4.43	NTSC4.43	MULTI-SYSTEM TV
	NTSC-PB	PAL TV
MESECAM	MESECAM	MULTI-SYSTEM TV

Before Operation - DVD part

General Explanation

This manual gives the basic instructions for operating this unit. Some DVDs require specific operation or allow only limited operation during playback. When this occurs, the symbol  appears on the TV screen, indicating that the operation is not permitted by this unit or is not available on the disc.









On-Screen Display

The general playback status can be displayed on the TV screen. Some items can be changed on the menu.

On-screen display operation

- 1** Press **DISPLAY** during playback.
- 2** Press **▲** or **▼** to select an item.
The selected item will be highlighted.
- 3** Press **◀** or **▶** to change the setting of an item.
The number buttons can be also be used for setting numbers (e.g., title number). For some functions, press **OK** to execute the setting.







Temporary Feedback Field Icons

	Repeat Title
	Repeat Chapter
	Repeat Track (non-PBC Video CDs only)
	Repeat All Tracks (non-PBC Video CDs only)
	Repeat A-B
	Repeat Off
	Resume play from this point
	Action prohibited or not available





Notes

- Some discs may not provide all of the below On-Screen Display.
- If no button is pressed for 10 seconds, the On-Screen Display disappears.

DVD

Items		Function (Press ▲/▼ to select desired item)	Selection Method
Title Number	 1/3	Shows the current title number and total number of titles, and skips to the desired title number.	◀ / ▶, or Numbers, OK
Chapter Number	 1/12	Shows the current chapter number and total number of chapters, and skips to the desired chapter number.	◀ / ▶, or Numbers, OK
Time search	 0:16:57	Shows the elapsed playing time, and searches the point by the elapsed time directly.	Numbers, OK
Audio language and Digital Audio Output mode	 1 ENG □□□ 5.1 CH	Shows the current audio soundtrack language, encoding method, and channel number, and changes the setting.	◀ / ▶
Subtitle language	 OFF	Shows the current subtitles language, and changes the setting.	◀ / ▶
Angle	 1/1	Shows the current angle number and total number of angles, and changes the angle number.	◀ / ▶
Sound	 NORM.	Shows the current sound mode, and changes the setting.	◀ / ▶

VCD2.0 VCD1.1

Items		Function (Press ▲/▼ to select desired item)	Selection Method
Track Number	 1/4	Shows the current track number, total number of tracks and PBC On mode, and skip to the desired track number.	◀ / ▶, or Numeric, OK
Time	 0:16:57	Shows the elapsed playing time (Display only)	–
Audio Channel	 STER.	Shows the audio channel, and changes the audio channel.	◀ / ▶
Sound	 NORM.	Shows the current sound mode, and changes the setting.	◀ / ▶

Before Operation - DVD part (Cont'd)

Initial Settings

You can set your own Personal Preferences on this unit.

Initial Settings General Operation

- 1 Press SETUP.**
The setup menu appears.



- 2 Press ▲/▼ to select the desired item.**
The screen will show the current setting for the selected item, as well as alternate setting(s).
- 3 While the desired item is selected, press ►, then ▲/▼ to select the desired setting.**
- 4 Press OK to confirm your selection.**
Some items require additional steps.
- 5 Press SETUP, RETURN or PLAY ► to exit the setup menu.**

Language

Disc Language **DVD**

Select a language for the disc's Menu, Audio and Subtitle.

Original : The original language set for the disc is selected.

Other : To select another language, press number buttons to enter the corresponding 4-digit number according to the language code list on page 29. If you enter the wrong language code, press **CLEAR**.



Menu Language

Select a language for the setup menu. This is the menu you see when you press **SETUP**.



Picture

TV Aspect **DVD**

4:3 Letterbox: Select when a standard 4:3 TV is connected. Displays theatrical images with masking bars above and below the picture.

4:3 Panscan: Select when a standard 4:3 TV is connected. Displays pictures cropped to fill your TV screen. Either sides of the picture are cut off.

16:9 Wide: Select when a 16:9 wide TV is connected.

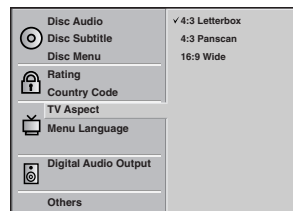

Before Operation - DVD part (Cont'd)

Sound

Digital Audio Output

Each DVD disc has a variety of audio output options. Set this unit's Digital Audio Output according to the type of audio system you use.

DOLBY DIGITAL/PCM: Select "DOLBY DIGITAL/PCM" if you connected this unit's DIGITAL OUT jack to a Dolby Digital decoder (or an amplifier or other equipment with a Dolby Digital decoder).

Stream/PCM: Select "Stream/PCM" if you connected this unit's DIGITAL OUT jack to an amplifier or other equipment with a DTS decoder, Dolby Digital decoder or MPEG decoder.

PCM: Select when connected to a 2 channel digital stereo amplifier. This unit outputs sounds in the PCM 2ch format when you play a DVD video disc recorded on the Dolby Digital, MPEG1 or MPEG2 recording system.

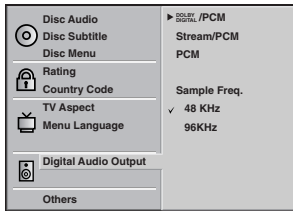

Sample Frequency

To change the Sample Frequency setting, first select the desired Digital Audio Output as indicated as above. If your receiver or amplifier is NOT capable of handling 96KHz signals, select 48KHz. When this choice is made, this unit will automatically convert any 96KHz signals to 48KHz so your system can decode them. If your receiver or amplifier is capable of handling 96KHz signals, select 96KHz. When this choice is made, this unit will pass each type of signal through without any further processing.

Others

The DRC, Vocal, and PBC settings can be changed.

- Press ▲/▼ to select the desired item and press **OK**. The setting of the selected item is changed between On and Off.



Dynamic Range Control (DRC)

With the DVD format, you can hear a program's soundtrack in the most accurate and realistic presentation possible, thanks to digital audio technology. However, you may wish to compress the dynamic range of the audio output (the difference between the loudest sounds and the quietest ones). Then, you may listen to a movie at a lower volume without losing clarity of sound. Set DRC to On for this effect.

Vocal

Set Vocal to On only when a multi-channel karaoke DVD is playing. The karaoke channels on the disc will mix into a normal stereo sound.

PBC

Set Playback Control (PBC) to On or Off.

- On:** Video CDs with PBC are played according to the PBC.
- Off:** Video CDs with PBC are played the same way as Audio CDs.

Before Operation - DVD part (Cont'd)

Parental Control

Rating **DVD**

Movies on DVDs may contain scenes not suitable for children. Therefore, discs may contain Parental Control information that applies to the complete disc or to certain scenes on the disc. These scenes are rated from 1 to 8, and alternatively, more suitable scenes are available for selection on some discs. Ratings are country-dependent. The Parental Control feature allows you to prevent discs from being played by your children or to have certain discs played with alternative scenes.

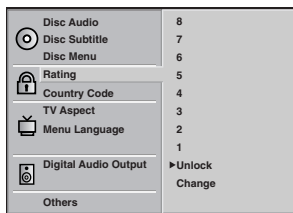

- 1** Select "Rating" on the Setup menu using the ▲ and ▼ buttons.
- 2** While "Rating" is selected, press ►.
- 3** When you have not entered a password yet. Enter a 4-digit password using the numbered buttons to create a personal 4-digit security password, then press **OK**. Enter the 4-digit password again and press **OK** to verify.
When you have already entered a password; Enter a 4-digit password using the numbered buttons to confirm the personal 4-digit security password, then press **OK**.
If you make a mistake before pressing **OK**, press **CLEAR** and enter 4-digit security password again.
- 4** Select a rating from 1 to 8 using the ▲/▼ buttons. One (1) has the least playback restrictions. Eight (8) has the most playback restrictions.
Unlock: If you select **Unlock**, Parental Control is not active. The disc will play in full.
Ratings 1 to 8: Some discs contain scenes not suitable for children. If you set a rating for the player, all disc scenes with the same rating or lower will be played. Higher rated scenes will not be played unless an alternative scene is available on the disc. The alternative must have the same rating or a lower one. If no suitable alternative is found, playback will stop. You must enter the 4-digit password or change the rating level in order to play the disc.
- 5** Press **OK** to confirm your rating selection, then press **SETUP** to exit the menu.

Country Code **DVD**

Enter the code of a country/area whose standards were used to rate the DVD video disc, referring to the list (See "Country Code List", page 30).

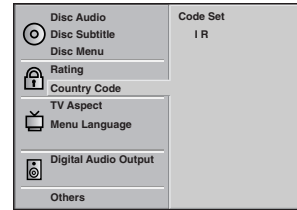

- 1** Select Country Code using the ▲/▼ buttons on the setup menu.
- 2** While Country Code is selected, press ►.
- 3** Follow step 3 of "Rating" on left.
- 4** Select the first character using the ▲/▼ buttons.
- 5** Shift the cursor using ◀▶ buttons and select the second character using ▲/▼ buttons.
- 6** Press **OK** to confirm your country code selection, then press **SETUP** to exit the menu.

N Note

Confirmation of the 4-digit password is necessary when the code is changed (See "Changing the 4-digit code" below).

Changing the 4-digit code

- Follow Steps 1-2 as shown above to the left (Rating).
- Enter the old code, then press **OK**.
- Select **Change** using the ▲/▼ buttons then press **OK**.
- Enter the new 4-digit code, then press **OK**.
- Enter exactly the same code a second time and verify by pressing **OK**.
- Press **SETUP** to exit the menu.

If you forget your 4-digit code

If you forget your password, to clear the current password, follow the procedure below.

- Press **SETUP** to display the setup menu.
- Use the Number buttons to enter the 6-digit number "210499".
The 4-digit password is cleared.
- Enter a new code as shown above to the left (Rating).

Operation with tape

Playing a tape

You will only be able to load and eject video cassettes when your VCP is plugged into the mains. Your VCP may also playback recordings from NTSC tapes (on PAL TV).

Getting a better picture

When a cassette is inserted and playback started, the automatic tracking function works to get the best possible picture automatically. If the quality of the recording is poor, repeatedly press ▲ or ▼ on the remote control to manually adjust the tracking until any distortions have been removed. Press numbered 0 on the remote control to switch automatic tracking back on again.

1 Make sure that you have correctly connected your VCP as described earlier in this book.

Turn on your TV.

Press $\psi/1$ to turn on your VCP.

Insert the video cassette into your VCP.

The video cassette should have the window side facing up and the arrow facing away from you.

2 Press **PLAY** ► to start playing your tape. If you load a video cassette which has had its record protection tab removed, playback of the cassette will start automatically.

AUTO TRACKING

Your VCP will automatically adjust the tracking to give the best picture quality.

3 Press **II** to still a picture. Press **II** repeatedly to advance the tape frame by frame.

If you hold down **►►I**, the picture will be slowed down at about 1/19 times the normal playback. Tapes can be paused for up to 5 minutes. After 5 minutes your VCP will stop the tape to prevent damaging the tape or your VCP. Still picture quality can be improved slightly by pressing ▲ or ▼.

4 Press **PLAY** ► to continue playing your tape. **Picture search:**

During playing back press either **►►I** or **I◄◄** to this will enable you to rapidly wind the tape (7 times normal playback) see where you are on the tape.

Logic search:

During fast forwarding or rewinding press and hold **►►I** or **I◄◄** the picture will be played back at 7 times normal playback speed.

5 Press **■** to end playback. Press **▲**.

If the end of the tape is reached, your VCP will stop playback automatically, rewind, stop, eject the tape.

CM (Commercial Message) Skip

This feature enables you during playback of a tape to skip a commercial break in a few seconds, then resume normal playback.

While tape is playing press \odot on the remote control to skip commercial (or another programme material).

Repeatedly press \odot to skip :

1 press : 30 seconds

2 press : 60 seconds

3 press : 90 seconds

4 press : 120 seconds

5 press : 150 seconds

6 press : 180 seconds

OPR (Optimum Picture Response)

This feature automatically improves playback picture quality by adjusting your VCP to the condition of the tape.

Please note you may only set OPR when playing a tape.

1 Press **MENU**.

2 Press **◀** or **▶** to select OPR.

3 Press **OK**.

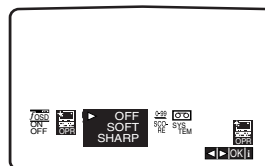

4 Press **◀** or **▶** repeatedly to select: **OFF**, **SOFT** or **SHARP**.

5 Press **OK**.

6 Press **MENU** to remove the menus.

Playing a DVD and Video CD

Playback Setup **DVD** **VCD2.0** **VCD1.1**

- Turn on the TV and select the video input source connected to the DVD player.
- Audio system: Turn on the audio system and select the input source connected to the DVD player.

1 Press **▲** to open the disc tray.

2 Load your chosen disc in the tray, with the label facing up.

When a double-sided DVD is inserted, make sure the side you want to play is facing up.

3 Press **▲** to close the tray.

READING appears on the TV screen, and playback starts automatically. If playback does not start, press **PLAY ▶**.

In some cases, the disc menu might appear instead.

If a menu screen is displayed

The menu screen may be displayed first after loading a DVD or Video CD which contains a menu.

DVD

Use the **◀ ▶ ▲ ▼** buttons to select the title/chapter you want to view, then press **OK** to start playback. Press **TITLE** or **TOP MENU** to return to the menu screen.

VCD2.0

- Use the number buttons to select the track you want to view.
Press **RETURN** to return to the menu screen.
- Menu setting and the exact operating procedures for using the menu may differ depending on the disc. Follow the instructions on the each menu screen. You also may set PBC to Off under setup. See page 16.

Notes

- If Parental Control is set and the disc is not within the Rating settings (not authorized), the 4-digit code must be entered and/or the disc must be authorized (see “Parental Control”, on page 17).
- DVDs may have a region code.
- Your player will not play discs that have a region code different from your player. The region code for this player is 2 (two).
- If you load a video cassette which has had its record protection tab removed during playing the DVD, the mode will be switched to VCP automatically.

General Features

Note

Unless stated otherwise, all operations described use the remote control. Some features may also be available on the Setup menu.

Moving to another TITLE **DVD**



When a disc has more than one title, you can move to another title as follows:

- Press **DISPLAY** when playback is stopped, then press the appropriate numbered button (0-9) to select a title number.

Moving to another CHAPTER/TRACK



When a title on a disc has more than one chapter or a disc has more than one track, you can move to another chapter/track as follows:

- Press **◀◀** or **▶▶** briefly during playback to select the next chapter/track or to return to the beginning of the current chapter/track.
- Press **◀◀** twice briefly to step back to the previous chapter/track.
- To go directly to any chapter during DVD playback, press **DISPLAY**. Then, press **▲▼** to select C (chapter) (or for a Video CD, select T for track). Then, enter the chapter/track number using the numbered buttons (0-9).

Note

For two-digit numbers, press the buttons in rapid succession.

Slow Motion **DVD** **VCD2.0** **VCD1.1**

- 1 Press **◀◀** or **▶▶** during pause.
The player will enter SLOW mode.
- 2 Use the **◀◀** or **▶▶** to select the required speed:
◀◀ 1/16, **◀◀ 1/8**, **◀◀ 1/4** or **◀◀ 1/2** (backward), or **▶▶ 1/16**, **▶▶ 1/8**, **▶▶ 1/4** or **▶▶ 1/2** (forward).
- 3 To exit slow motion mode, press **PLAY ▶**.

Note

Slow motion playback in reverse is not applicable for Video CD.

General Features (continued)

Still Picture and Frame-by-frame playback

DVD VCD2.0 VCD1.1

- 1 Press **II** during playback.
The player will now go into PAUSE mode.
- 2 You can advance the picture frame-by-frame by pressing **II** repeatedly on the remote control.

Search **DVD VCD2.0 VCD1.1**

- 1 Press and hold **◀◀** or **▶▶** for about two seconds during playback.
The player will now go into SEARCH mode.
- 2 Press and hold **◀◀** or **▶▶** repeatedly to select the required speed: **◀◀X2**, **◀◀X4**, **◀◀X16**, **◀◀X100** (backward) or **▶▶X2**, **▶▶X4**, **▶▶X16**, **▶▶X100** (forward).
With a Video CD, the Search speed changes: **◀◀X2**, **◀◀X4**, **◀◀X8** (backward) or **▶▶X2**, **▶▶X4**, **▶▶X8** (forward).
- 3 To exit SEARCH mode, press **▶**.

Random **Karaoke DVD VCD1.1**

- 1 Press **RANDOM** during playback or in stop mode.
The unit automatically begins Random Playback and "RANDOM" appears on the TV screen.
- 2 To return to normal playback, press **RANDOM** again until "NORMAL" appears on the TV screen.

T Tips

By pressing **◀◀** or **▶▶** during Random playback, the unit selects another title (track) and resumes Random playback.

N Note

This function only works with DVD Karaoke discs and video CD without PBC.

Repeat **DVD VCD2.0 VCD1.1**



DVD Video Discs - Repeat Chapter/Title/Off

- 1 To repeat the currently playing chapter, press **REPEAT**.
The Repeat Chapter icon appears on the TV screen.
- 2 To repeat the title currently playing, press **REPEAT** a second time.
The Repeat Title icon appears on the TV screen.
- 3 To exit Repeat mode, press **REPEAT** a third time.
The Repeat Off icon appears on the TV screen.

Video CDs - Repeat Track/All/Off

- 1 To repeat the track currently playing, press **REPEAT**.
The Repeat Track icon appears on the TV screen.
- 2 To repeat the disc currently playing, press **REPEAT** a second time.
The Repeat All icon appears on the TV screen.
- 3 To exit Repeat mode, press **REPEAT** a third time.
The Repeat Off icon appears on the TV screen.

N Note

On a Video CD with PBC, you must set PBC to Off on the setup menu to use the Repeat function. See page 16.

Repeat A-B **DVD VCD2.0 VCD1.1**



To repeat a sequence in a title:

- 1 Press **REPEAT A-B** at your chosen starting point.
A- appears briefly on the TV screen.
- 2 Press **REPEAT A-B** again at your chosen end point.
A-B appears briefly on the TV screen, and the repeat sequence begins (a-b repeat appears on the player's display).
- 3 To cancel the sequence, press **REPEAT A-B**.

Time Search **DVD**



The Time Search function allows you to start playing at any chosen time on the disc.

- 1 Press **DISPLAY** during playback. The on-screen display appears on the screen.
The Time Search box shows the elapsed playing time of the current disc.
- 2 Within 10 seconds, press **▲/▼** to select the Time Search icon in the on-screen display.
The ":-:--:" appears in the Time Search box.
- 3 Within 10 seconds, use the number buttons to enter the required start time. Enter hours, minutes, and seconds from left to right in the box.
If you enter the wrong numbers, press **CLEAR** to remove the numbers you entered. Then enter the correct numbers.
- 4 Within 10 seconds, press **OK** to confirm the start time.
Playback starts from the selected time on the disc. If you enter an invalid time, playback will continue from the current point.

3D Surround **DVD VCD2.0 VCD1.1**



This unit can produce a 3D Surround effect, which simulates multi-channel audio playback from two conventional stereo speakers, instead of the five or more speakers normally required to listen to multi-channel audio from a home theater system.

- 1 Press **DISPLAY** during playback.
- 2 Press **▲/▼** to select "NORM." or "3D SUR".
- 3 Press **◀▶** repeatedly until the desired sound is selected.

General Features (continued)

Zoom

The Zoom function allows you to enlarge the video image and to move through the enlarged image.

- 1 Press **ZOOM** during playback or still playback to activate the Zoom function.
If you press **ZOOM** repeatedly, the magnification level increases up to six times.
- 2 Use the **◀▶ ▲ ▼** buttons to move through the zoomed picture.
- 3 Press **CLEAR** to resume normal playback or return to the paused image.

Notes

- The zoom function may not work for some DVDs.
- The zoom function may not work on multi-angle scenes.

Marker Search



You can start playback from a memorized point. Up to nine points can be memorized.

To enter a mark, follow these steps.

- 1 During disc playback, press **MARKER** when playback reaches the spot that you want to memorize.
The Marker icon will appear on the TV screen briefly.
- 2 Repeat step 1 to enter up to nine Marker points on a disc.

To Recall a Marked Scene

- 1 During disc playback, press **SEARCH**.
The MARKER SEARCH menu will appear on the screen.
- 2 Within 10 seconds, press **◀▶** to select a Marker number that you want to recall.
- 3 Press **OK**.
Playback will start from the Marked scene.
- 4 To remove the MARKER SEARCH menu, press **SEARCH**.

To clear a Marked Scene

- 1 During disc playback, press **SEARCH**.
The MARKER SEARCH menu will appear on the screen.
- 2 Press **◀▶** to select the Marker number that you want to erase.
- 3 Press **CLEAR**.
The Marker number will be erased from the list.
- 4 Repeat steps 2 and 3 to erase additional Marker numbers.
- 5 To remove the MARKER SEARCH menu, press **SEARCH**.

Special DVD Features

Checking the contents of DVD Video discs: Menus

DVDs may contain menus that allow you to access special features. To use the disc menu, press **TOP MENU**. Then, press the appropriate number button to select an option. Or, use the **◀▶/▲/▼** buttons to highlight your selection, then press **OK**.

Title Menu

- 1 Press **TITLE**.
If the current title has a menu, the menu will appear on the screen. Otherwise, the disc menu may appear.
- 2 The menu can list camera angles, spoken language and subtitle options, and chapters for the title.
- 3 To remove the title menu, press **TITLE** again.

Disc Menu

- 1 Press **TOP MENU**.
The disc menu is displayed.
- 2 To remove the disc menu, press **TOP MENU** again.

Camera Angle

If the disc contains scenes recorded at different camera angles, you can change to a different camera angle during playback.

- Press **ANGLE** repeatedly during playback to select a desired angle.
The number of the current angle appears on the display.

Changing the Audio Language



Press **A. MONITOR** repeatedly during playback to hear a different audio language or audio track.

Subtitles

Press **SUBTITLE** repeatedly during playback to see the different subtitle languages.

Note

If  appears, the feature is not available on the disc.

Operation with Audio CD and MP3 Discs

Playing an Audio CD and MP3 discs

The DVD Player can play MP3 formatted recordings on CD-ROM, CD-R, or CD-RW discs.

Before playing MP3 recordings, read the notes on MP3 Recordings on page 25.

- 1 Insert a disc and close the tray.**
The menu appears on the TV screen.

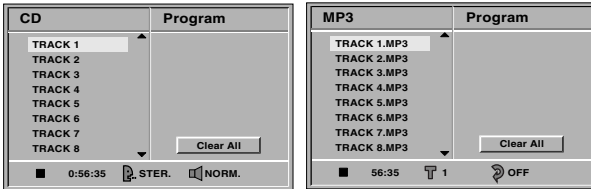

Audio CD menu

MP3 menu

- 2 Press ▲/▼ to select a track then press PLAY ►.**
Playback starts.
During playback, the current track's elapsed playing time will appear on the display.
Playback will stop at the end of the disc.

- 3 To stop playback at any other time, press ■.**

Pause **CD** **MP3**

- 1 Press **II** during playback.
- 2 To return to playback, press **PLAY ►** or press **II** again.

Moving to another Track **CD** **MP3**

- Press **I◀◀** or **▶▶I** briefly during playback to go to the next track or to return to the beginning of the current track.
- Press **I◀◀** twice briefly to step back to the previous track.
- In case of audio CD, to go directly to any track, enter the track number using the numbered buttons (0-9) during playback.

Repeat Track/All/Off **CD** **MP3**

- 1 To repeat the track currently playing, press **REPEAT**.
The Repeat Track icon appears on the menu screen.
- 2 To repeat all tracks on a disc, press **REPEAT** a second time.
The Repeat ALL icon appears on the menu screen.
- 3 To cancel Repeat mode, press **REPEAT** a third time.
The Repeat OFF icon appears on the menu screen.

Search **CD**

- 1 Press and hold **I◀◀** or **▶▶I** for about two seconds during playback.
The player will now go into SEARCH mode.
- 2 Press and hold **I◀◀** or **▶▶I** repeatedly to select the required speed: **◀◀X2**, **◀◀X4**, **◀◀X8** (backward) or **▶▶X2**, **▶▶X4**, **▶▶X8** (forward).
- 3 Search speed and direction are indicated on the menu screen.
- 4 To exit SEARCH mode, press **PLAY ►**.

Random **CD**

- 1 Press **RANDOM** during playback or when playback is stopped.
The unit automatically begins Random Playback and "RAND." appears on the menu screen.
- 2 To return to normal playback, press **RANDOM** repeatedly until "RAND." disappears on the menu screen.

Repeat A-B **CD**

To repeat a sequence.

- 1 During disc playback, press **REPEAT A-B** at your chosen starting point.
The Repeat icon and "A -" appears on the menu screen.
- 2 Press **REPEAT A-B** again at your chosen end point.
The Repeat icon and "A B" appears on the menu screen, and the sequence begins to play repeatedly.
- 3 To exit the sequence and return to normal play, press **REPEAT A-B** again.
The Repeat icon and "OFF" appear on the menu screen.

3D Surround **CD**

This unit can produce a 3D Surround effect, which simulates multi-channel audio playback from two conventional stereo speakers, instead of the five or more speakers normally required to listen to multi-channel audio from a home theater system.

- 1 Press **DISPLAY** or **A. MONITOR** during playback.
- 2 Press **◀▶** to select "NORM." or "3D SUR".
- 3 Press **▲/▼** repeatedly until the desired sound is selected.

Changing the Audio Channel **CD**

Press **A. MONITOR** repeatedly during playback to hear a different audio channel (STEREO, LEFT, or RIGHT).

Programmed Playback with Audio CD and MP3 Discs

Program allows you to store your favorite tracks for a particular disc in the player memory.

Program can contain 32 tracks (Audio CD) or 60 tracks (MP3 disc).

1 Insert the disc and close the tray.
The menu is displayed on the TV screen.

2 Press **PROG.** during playback or in the stop mode to enter the Program Edit mode.

The **[E]** mark will appear to the right of the word Program on the right side of the menu screen.

Note

Press **PROG.** to exit the Program Edit mode; the **[E]** mark will disappear.

3 Press **▲/▼** to select a track, then press **OK** to place the selected track on the Program list.

4 Repeat step 3 to place additional tracks on the Program list.

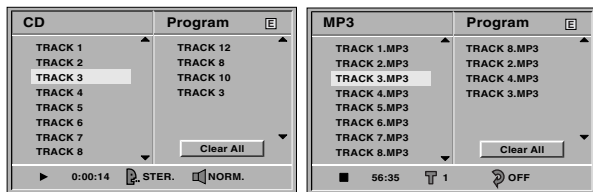

Audio CD menu

MP3 menu

5 Press **▶**.
The programmed track you selected last is highlighted on the program list.

6 Press **▲/▼** to select the track you want to start playing.

Press **TITLE** to move to the next page.
Press **TOP MENU** to move to the previous page.

7 Press **PLAY ▶** to start.

Playback begins in the order in which you programmed the tracks and “PROG.” appears on the display window. Playback stops after all of the tracks on the Program list have played once.

Programmed Playback with Video CD

Note

On a Video CD with PBC, you must set PBC to Off on the setup menu to use the Program function. See page 16.

1 Insert Video CD and close the tray.

2 Press **PROG.** while playback is stopped.
The VCD Program menu will appear.

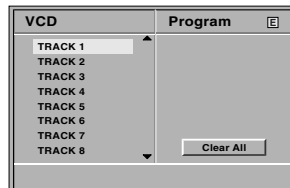

Note

Press **RETURN** or **PROG.** to exit the Program menu.

3 Follow steps 3-7 of “Programmed Playback with Audio CD and MP3 Disc” on left.

Repeat Programmed Tracks

- To repeat the track currently playing, press **REPEAT**. The Repeat Track icon appears on the menu screen.
- To repeat all tracks on the program list, press **REPEAT** a second time. The Repeat All icon appears on the menu screen.
- To cancel Repeat mode, press **REPEAT** a third time. The Repeat Off icon appears on the menu screen.

Erasing a Track from Program List

1 Press **PROG.** during playback or in the stop mode to enter the Program Edit mode.

The **[E]** mark will appear.

2 Press **▶** to move to the Program list.

3 Use **▲/▼** to select the track that you wish to erase from the Program list.

4 Press **CLEAR**.

The track will be erased from the Program list.

Erasing the Complete Program List

1 Follow steps 1-2 of “Erasing a Track from Program List” as above.

2 Use **▲/▼** to select “Clear All”, then press **OK**.

The complete Program for the disc will be erased.

The programs are also cleared when the disc is removed.

To resume normal playback from programmed playback

Press and hold **PROG.** for 3 seconds until “PROG.” indicator disappears in the display window.

Additional Operation - VCP part

On Screen Display

You may easily display the operating mode, tape speed, colour system, audio output channel and tape counter of your VCP on the TV screen. If a recording is taking place these On Screen Displays will not be recorded onto the tape.

Be sure to set OSD to ON.

1 Press **DISPLAY** to display.
The tape counter does not appear if there is no tape loaded.

2 After 3 seconds the majority of the On Screen Displays will clear leaving only the tape counter on the screen.
Press **DISPLAY** again to remove all displays from the TV screen.

Tape Counter Memory Stop

The **Digital Tape Counter** is displayed on the display window if there is a tape loaded. The Digital Tape Counter indicates the relative positions of recordings on the tape.

Be sure to set OSD to ON.

The counter is automatically reset to 0:00:00 and "M" appears on the TV screen.

1 Press **DISPLAY**.
Press **CLEAR** to set the counter to 0:00:00.
Press **PLAY** ► or start recording.
The tape counter will display the actual play time in hours, minutes and seconds.

2 Press ■ when playback or recording is complete.
Press ◀◀.
The tape will rewind and automatically stop when the counter returns to 0:00:00.

Video Doctor (Self-Diagnosis)

This feature informs you that there is a problem with your VCP. These error messages will appear on the TV screen.

1 Press **MENU**.
Press ◀ or ▶ to select **DR**.
Press **OK**.

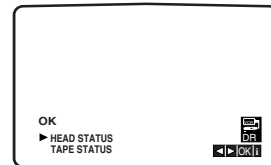

2 Press ◀ or ▶ to check a problem.
HEAD STATUS
● **OK**
● **PLEASE CLEAN:**
Clean your video heads.

TAPE STATUS

● **RECORDABLE**
● **NOT RECORDABLE:**
Insert a tape with its protection tab in place.

3 Press **OK**.

4 Press **MENU** to remove menus from the TV screen.

Hi-Fi Stereo Sound System

Press **A. MONITOR** repeatedly until the desired audio mode appears.

The choice is **HI-FI (STEREO)**, **LEFT**, **RIGHT** and **MONO**.

Last Condition Memory

DVD **CD** **VCD1.1**

This player memorizes the last condition for the last disc you have watched. Settings remain in memory even if you remove the disc from the player or switch off the player. If you load a disc that has its settings memorized, the latest stop position is automatically recalled.

Notes

- Settings are stored in memory for use any time.
- This player does not memorize settings of a disc if you switch off the player before commencing to play it.

Screen Saver

The screen saver picture appears when you leave the DVD Player in stop mode for about five minutes.

Video Mode Setting **DVD** **VCD2.0** **VCD1.1**

- With certain discs, the playback picture may be flickering or Dot Crawl is shown on straight lines. That means Vertical interpolation or De-interlace is not perfectly matched with the disc. In this case, the picture quality may be improved by changing the video mode.
- To change the video mode, press and hold **DISPLAY** about 3 seconds during disc playback. The new video mode number selected is displayed on the TV screen. Check whether the video quality has improved. If not, repeat the above procedure until picture quality is improved.
- Video mode change sequence:
MODE1 → MODE2 → MODE3 → MODE4 → MODE5 → MODE1
- If you turn off the the power, the video mode will be back to initial state (MODE1).

Notes on MP3 Discs

About MP3

- An MP3 file is audio data compressed by using MPEG1, the audio layer-3 file-coding scheme. We call files that have the “.mp3” file extension “MP3 files”.
- The player can not read an MP3 file that has a file extension other than “.mp3”.
- The player can not read a fake MP3 file that has a file extension “.mp3”.

MP3 Disc compatibility with this player is limited as follows:

1. Sampling Frequency / only at 44.1kHz
2. Bit rate/ within 32 - 320kbps
3. CD-R physical format should be “ISO 9660”
4. If you record MP3 files using the software which cannot create a FILE SYSTEM, for example “Direct-CD” etc., it is impossible to playback MP3 files. We therefore recommend that you use “Easy-CD Creator”, which creates an ISO9660 file system.
5. A single session disc requires MP3 files in the first track. If there is no MP3 file in the 1st track, it cannot playback MP3 files. If you wish to playback MP3 files, format all the data in the disc or use a new one.
6. We do not recommend using CD-RW discs. Please use finished CD-R discs only.
7. File names should be named using 8 letters or less and must incorporate the “.mp3” extension e.g. “*****.MP3”.
8. Do not use special characters such as “_?!><+*}{[@] ; ; V . , ” etc.
9. Total number of files on the disc should be less than 200.
10. Use 74 minute CD-R discs (650M), do not use 80 minute CD-R (700M) software.

This DVD player requires discs/recordings to meet certain technical standards in order to achieve optimal playback quality. Pre-recorded DVDs are automatically set to these standards. There are many different types of recordable disc formats (including CD-R containing MP3 files).

Customers should also note that permission is required in order to download MP3 files and music from the Internet. Our company has no right to grant such permission. Permission should always be sought from the copyright owner.

Special Operation - Karaoke function

Before you start karaoke

Note

You cannot enjoy Karaoke from DVD exclusive out.

You can sing along with a karaoke source (video tape, VCD, audio CD, Karaoke DVD). You can sing duets if you use an extra microphone.

1 Turn on your TV and set it to the AV. When using an amplifier, turn on the amplifier and select this player position.

2 Connect a microphone to the MIC 1 jack. To sing duets, connect another microphone to MIC 2 jack.

Karaoke sing-along

Singing along with karaoke video tapes

1 Insert a karaoke video tape. The player turns on and starts playing automatically if you insert a tape with its safety tab removed.

2 Press **PLAY** ▶.
If you want to play back a specific song, perform the Karaoke search.
• Karaoke search will be operated only when a microphone has been plugged in.

Karaoke search

Press ◀ or ▶ on the remote control.

Press ◀ or ▶ again to play a desired song.

3 Now you can enjoy playing karaoke.

Singing along with karaoke VIDEO CD or DVD

1 Press ▲, and place the disc on the disc tray.

2 Press **PLAY** ▶.
The disc tray closes and starts.

3 Now you can enjoy playing karaoke.

To adjust the microphone volume

Press **MIC/ECHO** to select the MIC control mode.

Press ▲/▼ for the microphone connected to MIC 1/2. Setting the microphone volume to the centre position provides the best microphone volume.

“MIC : _ _ _” appears on the TV screen.

To control the echo effect

Press **MIC/ECHO** to select the ECHO control mode.

Press ▲/▼. This controls both microphones' echo effect in the same way.

To get the best effect, adjust the microphone volume to a level slightly higher than the music volume.

“ECHO : _ _ _” appears on the TV screen.

Note

The microphone volume and the echo effect will be reset to the default setting once you disconnect the AC power cord.

Grading your singing

As an extra challenge, this player can grade your singing.

When you have finished singing, your score appears on the TV screen.

Notes

- The unit cannot grade your singing if there is no blank portion between the tracks.
- If the sound is reproduced through a stereo amplifier, turn down the volume of amplifier before operation.
- If streaks appear during playback, select the colour system that the tape was recorded in (see “To set the colour system” on page 13).
- If feedback occurs, turn down the microphone or TV volume, or move the microphone away from the speakers.

Copying from DVD to VCP

This unit allows you to copy the contents of a DVD to a VHS tape with a press of the ● button.

Note

If the DVD you are attempting to copy is copy protected, you may not be able to copy the disc.

1 Insert Disc

Insert the disc you wish to copy in the DVD deck and close the disc tray.

2 Insert VHS Tape

Insert a blank VHS video tape into the VCP deck.

3 Press DVD so that the DVD indicator lights up.

4 Copy the DVD to VHS tape

Press ●.

- The DVD will go into Play mode and the VCP will go into Record mode.
- If the DVD disc menu appears, you may need to press **PLAY ►** manually to begin copying.
- If you try to record the copy protected programme, "COPY PROTECTED DISC" appears on the TV screen and "LOCK" appears on the display window.
- Press **II** to still a picture.

5 Stop the Copy Process

Press ■.

Recording from another video player

With this video player you can make recordings from an external source, such as copying from another video player or a camcorder.

Note

In the following description, this video player will be one used for recording and will be referred to as VCP B. The other appliance will be used for playback and will be referred to as VCP A.

1 VCP A should be connected to the AUDIO L/R (VHS IN)/VIDEO (VHS IN) jack on the rear panel of your VCP.

2 Insert the recorded tape into VCP A and a blank tape into VCP B.

3 To start recording, press ● on VCP B and **PLAY ►** on VCP A.

4 When you want to finish copying, press **STOP** on both video players.

Troubleshooting

Check the following guide for the possible cause of a problem before contacting service.

Symptom	Cause	Correction
DVD or VCP do not work properly.	<ul style="list-style-type: none"> DVD or VCP button is not switched properly. 	<ul style="list-style-type: none"> Press DVD or VCP on the remote control, or DVD/VCP on the front panel to switch the control.
No power.	<ul style="list-style-type: none"> The power cord is disconnected. 	<ul style="list-style-type: none"> Plug the power cord into the wall outlet securely.
The power is on, but the DVD player does not work.	<ul style="list-style-type: none"> No disc is inserted. 	<ul style="list-style-type: none"> Insert a disc. (Check that the DVD or, audio CD indicator in the display window is lit.)
No picture.	<ul style="list-style-type: none"> The TV is not set to receive DVD signal output. 	<ul style="list-style-type: none"> Select the appropriate video input mode on the TV so the picture from the DVD player appears on the TV screen.
No sound.	<ul style="list-style-type: none"> The equipment connected with the audio cable is not set to receive DVD signal output. 	<ul style="list-style-type: none"> Select the correct input mode of the audio receiver so you can listen to the sound from the DVD player.
	<ul style="list-style-type: none"> The audio cables are not connected securely. 	<ul style="list-style-type: none"> Connect the audio cable into the jacks securely.
	<ul style="list-style-type: none"> The power of the equipment connected with the audio cable is turned off. 	<ul style="list-style-type: none"> Turn on the equipment connected with the audio cable.
	<ul style="list-style-type: none"> The Digital Audio Output is set to the wrong position. 	<ul style="list-style-type: none"> Set the Digital Audio Output to the correct position, then turn on the DVD player again by pressing POWER.
The picture is poor.	<ul style="list-style-type: none"> The disc is dirty. 	<ul style="list-style-type: none"> Clean the disc.
The DVD player does not start playback.	<ul style="list-style-type: none"> An unplayable disc is inserted. 	<ul style="list-style-type: none"> Insert a playable disc. (Check the disc type, color system and Regional code.)
	<ul style="list-style-type: none"> The disc is placed upside down. 	<ul style="list-style-type: none"> Place the disc with the playback side down.
	<ul style="list-style-type: none"> The disc is not placed within the guide. 	<ul style="list-style-type: none"> Place the disc on the disc tray correctly inside the guide.
	<ul style="list-style-type: none"> The disc is dirty. 	<ul style="list-style-type: none"> Clean the disc.
	<ul style="list-style-type: none"> The Rating level is set. 	<ul style="list-style-type: none"> Cancel the Rating function or change the rating level.
The remote control does not work properly.	<ul style="list-style-type: none"> There is an obstacle in the path of the remote control and this unit. 	<ul style="list-style-type: none"> Remove the obstacle.
	<ul style="list-style-type: none"> The batteries in the remote control are exhausted. 	<ul style="list-style-type: none"> Replace the batteries with new ones.
Video tape cannot be inserted.	<ul style="list-style-type: none"> Is the cassette compartment empty? 	<ul style="list-style-type: none"> Eject the tape in.
No Hi-Fi sound	<ul style="list-style-type: none"> Audio mode is not set properly. 	<ul style="list-style-type: none"> Select "HI-FI" by repeatedly pressing A. MONITOR on the remote control.

Video Head Cleaning

Whenever a video cassette is inserted into or ejected from your VCP, the video head is automatically cleaned. This should mean that additional head cleaning should not be necessary. However dirt accumulating on the head after a long period of time can cause the playback picture to become blurred or broken up. High quality video cassette tapes will not normally deposit dirt onto the video head, but old or damaged tapes might.

Language Code List

Enter the appropriate code number for the initial settings “Disc Audio”, “Disc Subtitle” and/or “Disc Menu” (See page 15).

Code	Language	Code	Language	Code	Language	Code	Language
6565	Afar	7079	Faroese	7678	Lingala	8375	Slovak
6566	Abkhazian	7082	French	7679	Laothian	8376	Slovenian
6570	Afrikaans	7089	Frisian	7684	Lithuanian	8377	Samoaan
6577	Ameharic	7165	Irish	7686	Latvian, Lettish	8378	Shona
6582	Arabic	7168	Scots Gaelic	7771	Malagasy	8379	Somali
6583	Assamese	7176	Galician	7773	Maori	8381	Albanian
6588	Aymara	7178	Guarani	7775	Macedonian	8382	Serbian
6590	Azerbaijani	7185	Gujarati	7776	Malayalam	8385	Sudanese
6665	Bashkir	7265	Hausa	7778	Mongolian	8386	Swedish
6669	Byelorussian	7273	Hindi	7779	Moldavian	8387	Swahili
6671	Bulgarian	7282	Croatian	7782	Marathi	8465	Tamil
6672	Bihari	7285	Hungarian	7783	Malay	8469	Telugu
6678	Bengali; Bangla	7289	Armenian	7784	Maltese	8471	Tajik
6679	Tibetan	7365	Interlingua	7789	Burmese	8472	Thai
6682	Breton	7378	Indonesian	7865	Nauru	8473	Tigrinya
6765	Catalan	7383	Icelandic	7869	Nepali	8475	Turkmen
6779	Corsican	7384	Italian	7876	Dutch	8476	Tagalog
6783	Czech	7387	Hebrew	7879	Norwegian	8479	Tonga
6789	Welsh	7465	Japanese	7982	Oriya	8482	Turkish
6865	Danish	7473	Yiddish	8065	Panjabi	8484	Tatar
6869	German	7487	Javanese	8076	Polish	8487	Twi
6890	Bhutani	7565	Georgian	8083	Pashto, Pushto	8575	Ukrainian
6976	Greek	7575	Kazakh	8084	Portuguese	8582	Urdu
6978	English	7576	Greenlandic	8185	Quechua	8590	Uzbek
6979	Esperanto	7577	Cambodian	8277	Rhaeto-Romance	8673	Vietnamese
6983	Spanish	7578	Kannada	8279	Rumanian	8679	Volapük
6984	Estonian	7579	Korean	8285	Russian	8779	Wolof
6985	Basque	7583	Kashmiri	8365	Sanskrit	8872	Xhosa
7065	Persian	7585	Kurdish	8368	Sindhi	8979	Yoruba
7073	Finnish	7589	Kirghiz	8372	Serbo-Croatian	9072	Chinese
7074	Fiji	7665	Latin	8373	Singhalese	9085	Zulu

Country Code List

Enter the appropriate code number for the initial setting "Country Code" (See page 17).

Code	Country	Code	Country	Code	Country	Code	Country
AD	Andorra	ER	Eritrea	LC	Saint Lucia	SC	Seychelles
AE	United Arab Emirates	ES	Spain	LI	Liechtenstein	SD	Sudan
AF	Afghanistan	ET	Ethiopia	LK	Sri Lanka	SE	Sweden
AG	Antigua and Barbuda	FI	Finland	LR	Liberia	SG	Singapore
AI	Anguilla	FJ	Fiji	LS	Lesotho	SH	Saint Helena
AL	Albania	FK	Falkland Islands	LT	Lithuania	SI	Slovenia
AM	Armenia	FM	Micronesia	LU	Luxembourg	SJ	Svalbard and Jan Mayen Islands
AN	Netherlands Antilles	FO	Faroe Islands	LV	Latvia	SK	Slovak Republic
AO	Angola	FR	France	LY	Libya	SL	Sierra Leone
AQ	Antarctica	FX	France (European Territory)	MA	Morocco	SM	San Marino
AR	Argentina	GA	Gabon	MC	Monaco	SN	Senegal
AS	American Samoa	GB	Great Britain	MD	Moldavia	SO	Somalia
AT	Austria	GD	Grenada	MG	Madagascar	SR	Suriname
AU	Australia	GE	Georgia	MH	Marshall Islands	ST	Saint Tome and Principe
AW	Aruba	GF	French Guyana	MK	Macedonia	SU	Former USSR
AZ	Azerbaijan	GH	Ghana	ML	Mali	SV	El Salvador
BA	Bosnia-Herzegovina	GI	Gibraltar	MM	Myanmar	SY	Syria
BB	Barbados	GL	Greenland	MN	Mongolia	SZ	Swaziland
BD	Bangladesh	GM	Gambia	MO	Macau	TC	Turks and Caicos Islands
BE	Belgium	GN	Guinea	MP	Northern Mariana Islands	TD	Chad
BF	Burkina Faso	GP	Guadeloupe (French)	MQ	Martinique (French)	TF	French Southern Territories
BG	Bulgaria	GQ	Equatorial Guinea	MR	Mauritania	TG	Togo
BH	Bahrain	GR	Greece	MS	Montserrat	TH	Thailand
BI	Burundi	GS	S. Georgia & S. Sandwich Isls.	MT	Malta	TJ	Tadjikistan
BJ	Benin	GT	Guatemala	MV	Maldives	TK	Tokelau
BM	Bermuda	GU	Guam (USA)	MW	Malawi	TM	Turkmenistan
BN	Brunei Darussalam	GW	Guinea Bissau	MX	Mexico	TN	Tunisia
BO	Bolivia	GY	Guyana	MY	Malaysia	TO	Tonga
BR	Brazil	HK	Hong Kong	MZ	Mozambique	TP	East Timor
BS	Bahamas	HM	Heard and McDonald Islands	NA	Namibia	TR	Turkey
BT	Bhutan	HN	Honduras	NC	New Caledonia (French)	TT	Trinidad and Tobago
BV	Bouvet Island	HR	Croatia	NE	Niger	TV	Tuvalu
BW	Botswana	HT	Haiti	NF	Norfolk Island	TW	Taiwan
BY	Belarus	HU	Hungary	NG	Nigeria	TZ	Tanzania
BZ	Belize	ID	Indonesia	NI	Nicaragua	UA	Ukraine
CA	Canada	IE	Ireland	NL	Netherlands	UG	Uganda
CC	Cocos (Keeling) Islands	IL	Israel	NO	Norway	UK	United Kingdom
CF	Central African Republic	IN	India	NP	Nepal	UM	USA Minor Outlying Islands
CG	Congo	IO	British Indian Ocean Territory	NR	Nauru	US	United States
CH	Switzerland	IQ	Iraq	NU	Niue	UY	Uruguay
CI	Ivory Coast	IR	Iran	NZ	New Zealand	UZ	Uzbekistan
CK	Cook Islands	IS	Iceland	OM	Oman	VA	Vatican City State
CL	Chile	IT	Italy	PA	Panama	VC	Saint Vincent & Grenadines
CM	Cameroon	JM	Jamaica	PE	Peru	VE	Venezuela
CN	China	JO	Jordan	PF	Polynesia (French)	VG	Virgin Islands (British)
CO	Colombia	JP	Japan	PG	Papua New Guinea	VI	Virgin Islands (USA)
CR	Costa Rica	KE	Kenya	PH	Philippines	VN	Vietnam
CS	Former Czechoslovakia	KG	Kyrgyzstan	PK	Pakistan	VU	Vanuatu
CU	Cuba	KH	Cambodia	PL	Poland	WF	Wallis and Futuna Islands
CV	Cape Verde	KI	Kiribati	PM	Saint Pierre and Miquelon	WS	Samoa
CX	Christmas Island	KM	Comoros	PN	Pitcairn Island	YE	Yemen
CY	Cyprus	KN	Saint Kitts & Nevis Anguilla	PR	Puerto Rico	YT	Mayotte
CZ	Czech Republic	KP	North Korea	PT	Portugal	YU	Yugoslavia
DE	Germany	KR	South Korea	PW	Palau	ZA	South Africa
DJ	Djibouti	KW	Kuwait	PY	Paraguay	ZM	Zambia
DK	Denmark	KY	Cayman Islands	QA	Qatar	ZR	Zaire
DM	Dominica	KZ	Kazakhstan	RE	Reunion (French)	ZW	Zimbabwe
DO	Dominican Republic	LA	Laos	RO	Romania		
DZ	Algeria	LB	Lebanon	RU	Russian Federation		
EC	Ecuador			RW	Rwanda		
EE	Estonia			SA	Saudi Arabia		
EG	Egypt			SB	Solomon Islands		
EH	Western Sahara						

Specification

General

Power requirements	AC 110-240V , 50/60 Hz
Power consumption	20W
Dimensions (approx.)	430 X 97.5 X 360 mm (w/h/d)
Mass (approx.)	5.3 kg
Operating temperature	5°C to 35°C
Operating humidity	5 % to 90 %

System

Laser	Semiconductor laser, wavelength 650 nm
Video Head system	Double azimuth 4 heads, helical scanning.
Signal system	PAL/NTSC
Frequency response	DVD (PCM 96 kHz): 2 Hz to 44 kHz DVD (PCM 48 kHz): 2 Hz to 22 kHz CD: 2 Hz to 20 kHz
Signal-to-noise ratio	More than 100dB (ANALOG OUT connectors only)
Harmonic distortion	Less than 0.008%
Dynamic range	More than 95 dB (DVD) More than 95 dB (CD)
Wow and flutter	Less than detected value ($\pm 0.001\%$ W PEAK)

Inputs (VCP)

Audio	-6.0dBm, more than 47 kohms
Video	1.0 Vp-p, 75 ohms, unbalanced

Outputs (DVD)

VIDEO OUT	1 Vp-p 75 ohms, sync negative
COMPONENT VIDEO OUT	(Y) 1.0 V (p-p), 75 Ω , negative sync., RCA jack x 1 (Pb)/(Pr) 0.7 V (p-p), 75 Ω , RCA jack x 2
Audio output (digital audio)	0.5 V (p-p), 75 Ω , RCA jack x 1
Audio output (analog audio)	2.0 Vrms (1 KHz, 0 dB), 330 Ω , RCA jack (L, R)

Outputs (VCP/DVD)

Audio	-6.0dBm, less than 1 kohms
Video	1.0 Vp-p, 75 ohms, unbalanced

Manufactured under license from Dolby Laboratories. "Dolby" and the double-D symbol are trademarks of Dolby Laboratories. Confidential unpublished works. Copyright 1992-1997 Dolby Laboratories. All rights reserved.

"DTS" and "DTS Digital Out" are trademarks of Digital Theater Systems, Inc.

- Design and specifications are subject to change without notice.



SECTION 6 REPLACEMENT PARTS LIST

SAFETY PRECAUTION

Parts identified by the ⚠ symbol are critical for safety. Replace only with specified part numbers.

6.1 EXPLODED VIEW

6.1.1 PACKING AND ACCESSORY ASSEMBLY <M1>

The instruction manual to be provided with this product will differ according to the destination.

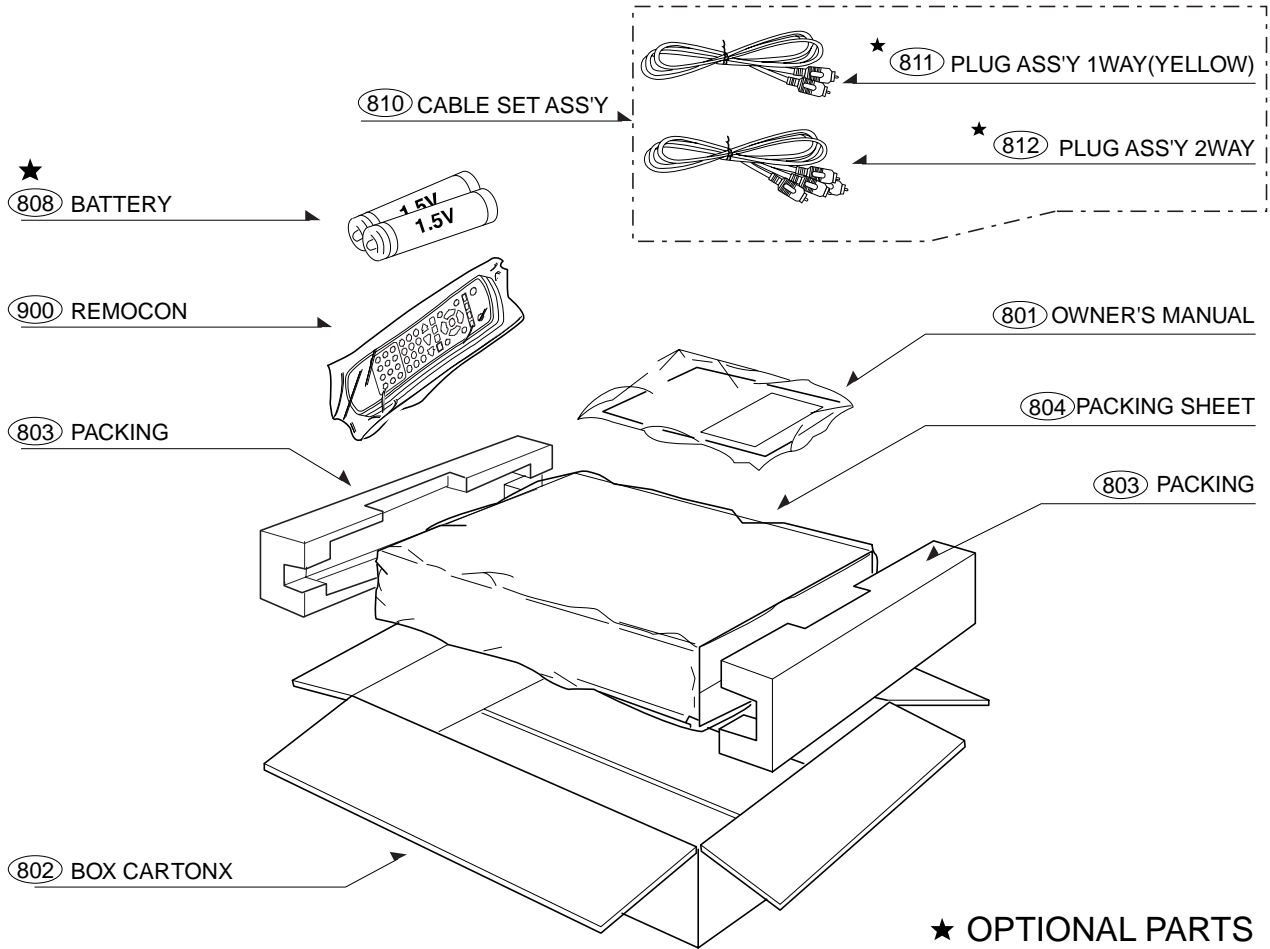

6.1.2 FINAL ASSEMBLY <M2>

BEWARE OF BOGUS PARTS

Parts that do not meet specifications may cause trouble in regard to safety and performance. We recommend that genuine JVC parts be used.

★OPTIONAL PARTS

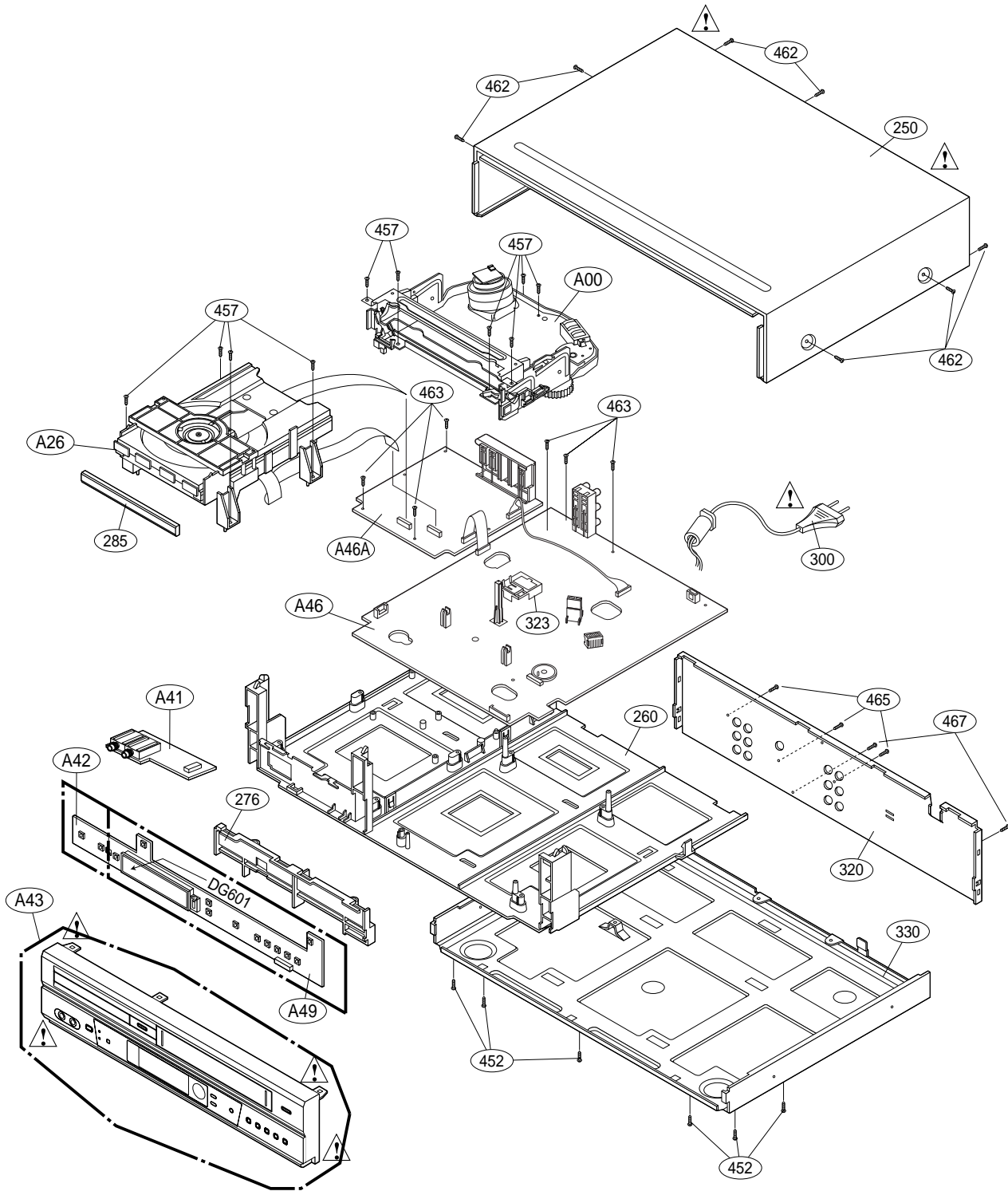

6.1.3 MECHANISM ASSEMBLY(VCR) <M4>

★OPTIONAL PARTS

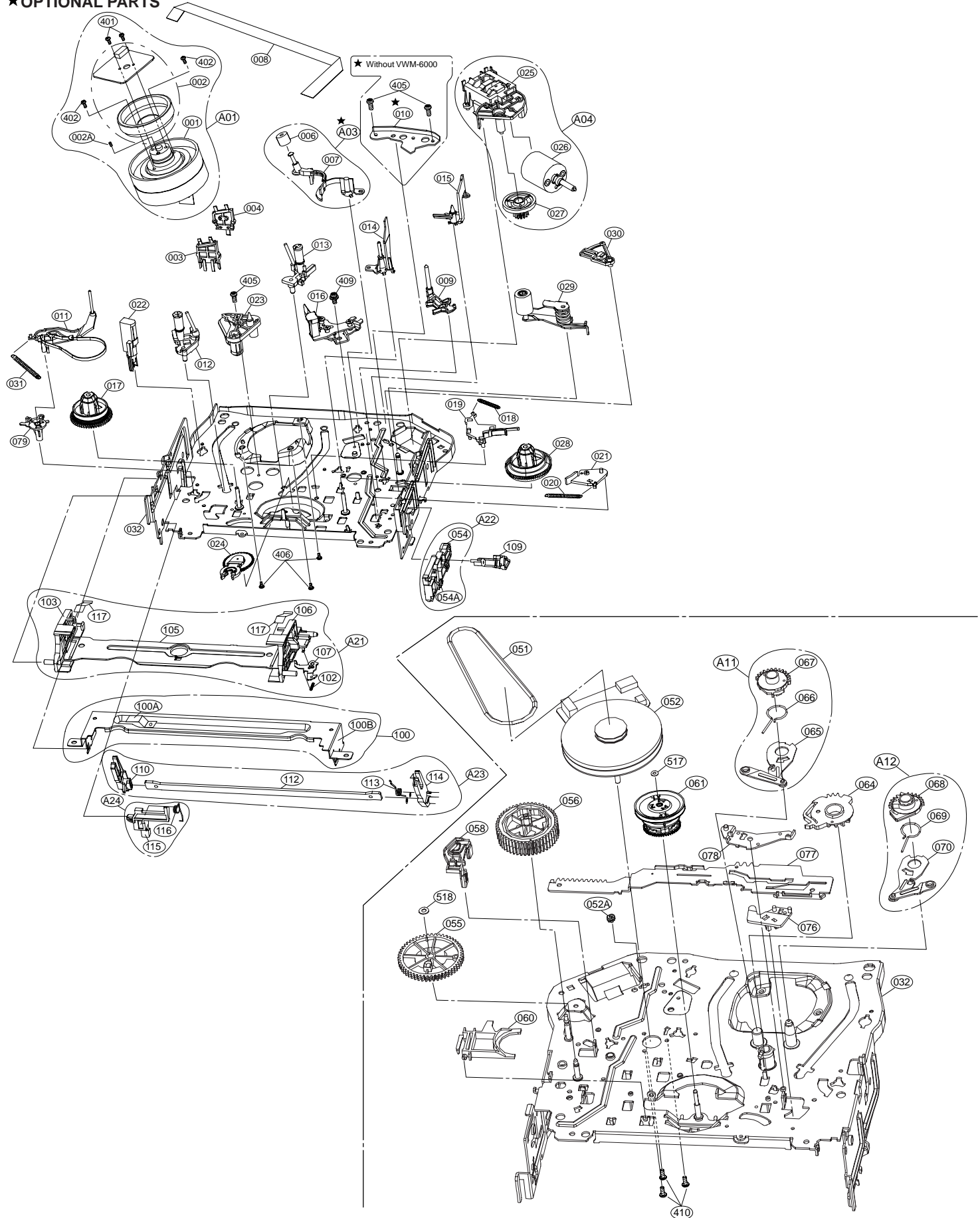

6.1.4 MECHANISM ASSEMBLY(DVD) <MN>
★OPTIONAL PARTS

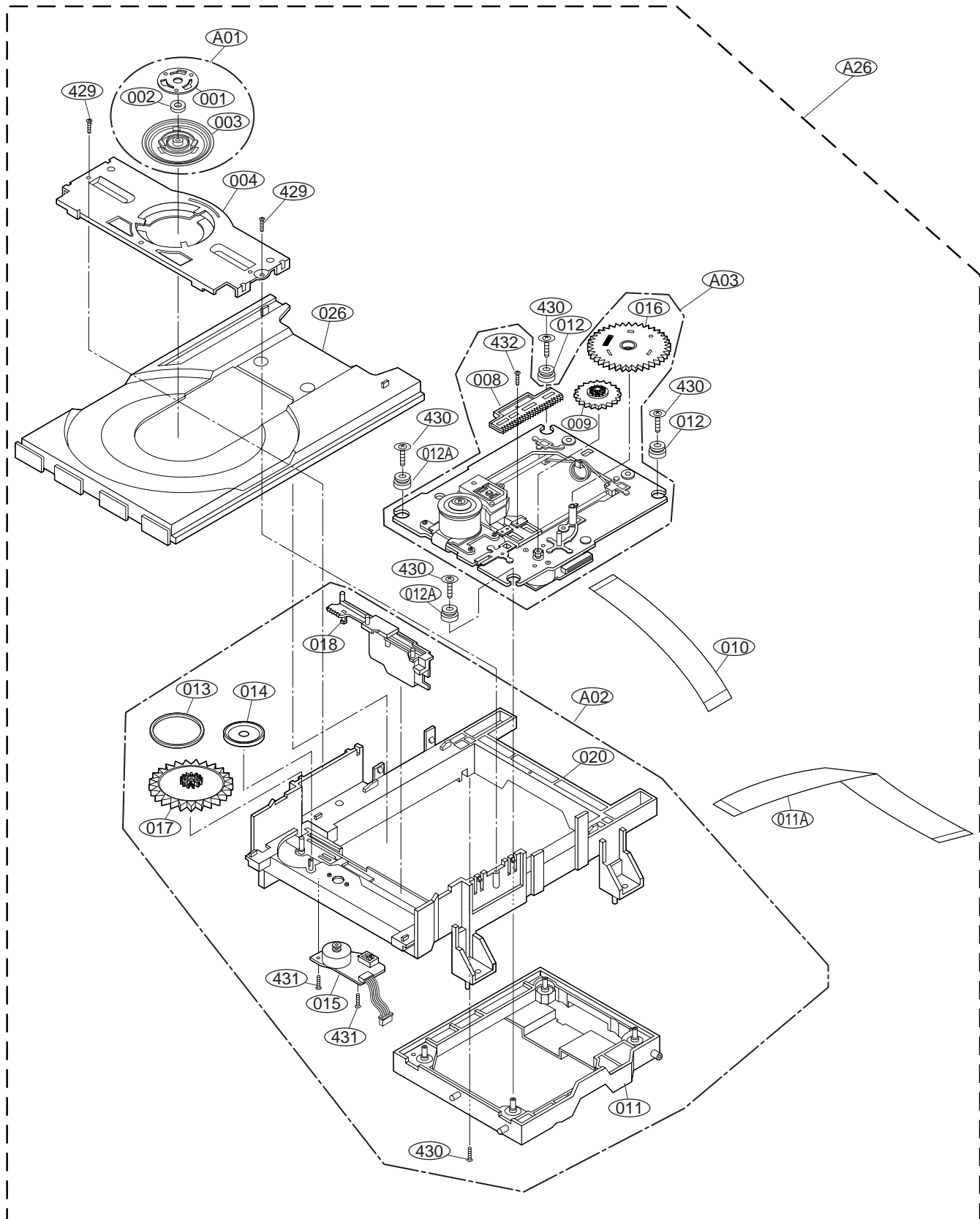

6.2 REPLACEMENT PARTS LIST

*NSP : Not service parts

#	REF No.	PART No.	PART NAME, DESCRIPTION	SPECIFICATION	NSP

PACKING AND ACCESSORY ASSEMBLY <M1>					
801	LG 3835RP0075X	INSTRUCTION ASSEMBLY	DCJK503WQ.EVNT		
802	LG 3890R H024F	BOX			
803	LG 3920R E051A	PACKING,CASING	DC590 S(DVD.VCR) 0.02 80 EPE 4		
804	LG 292 053A	BAG	SOFT(VCP)		NSP
808		BATTERY,MANGANESE	AAAM(R03) SEOTONG 1 5 V 1PA		
810		CABLE ASSY,RF	DVD PAL CABLE ASSY,RCA USING A		
811	PU59205 4	PLUG ASSY	1WAY YELLOW GLOBAL		
812	PU56142 5	PLUG ASSY	2WAY RED/WHITE GLOBAL		
900	LG 6711R1P047A	REMOTE CONTROLLER ASSEMBLY	N6 DC.JK503W JVC/KARAOKE		

FINAL ASSEMBLY <M2>

A41	LG 6871R 5720B	PWB(PCB) ASSEMBLY,TOTAL	KARAOKE JACK DC.JK503WQ		
A42	LG 3501R 6334A	BOARD ASSEMBLY	JVC KARAOKE KEY		
A43	LG 3721R F328A	PANEL ASSEMBLY,FRONT	FRONT HR XV10AG/JCV KARAOKE CO		
A46	LG 3501R 4938W	BOARD ASSEMBLY	MAIN DC.JK503WQ		
A46A	LG 6885R 0260A	SUB PWB(PCB) ASSEMBLY	495200CA 120500 FF B200020AC8 (
A49	LG 3501R 6333A	BOARD ASSEMBLY	JVC KARAOKE TIMER		
250	LG 3110R P009A	CASE	VCR TOP(DVD+VCR)		
260	LG 3211R 0039B	FRAME ASSEMBLY	VCR MAIN(DVD+VCR) KARAOKE		NSP
276	LG 4930R 0298B	HOLDER,SHELF	VCR TIMER PWB(D+V RIB CUTTIN		
280	LG 3720R F189T	PANEL	FRONT		NSP
283	LG 3560R V050A	DOOR CASE	CST		
284	LG 442 681A	SPRING	DOOR		
300	LG 6410RCHS02C	POWER CORD	EP11 LTFZ 2F 2*0.75 EMI OR SAN		
323	LG 3111R 0089B	CASE ASSY	PRE AMP (PBSB SH)		
330	LG 3140R 0042A	CHASSIS	VCR MAIN(DVD+VCR)		
452	LG 353 051A	SCREW	SPECIAL		
457	LG 353 051E	SCREW	SPECIAL (3X12)		
462	LG 353 085F	SCREW,DRAWING	+ 3 D4.0 L10.0 MSWR3/FN		
467	LG 353 051G	SCREW,DRAWING	+ 2 D3.0 L8.0 MSWR3/FN TB ROUN		

MECHANISM ASSEMBLY(VCR) <M4>

A00	LG 6721R 0750E	DECK ASSEMBLY,VIDEO	D35(N) (4HF, PAL, AHC(O), B/C)		NSP
A11	LG 4471R 0005A	GEAR ASSY	P3		
A12	LG 4471R 0004A	GEAR ASSY	P2		
A21	LG 4931R 0047A	HOLDER ASSY	CST		
A22	LG 4471R 0006A	GEAR ASSY	RACK F/L		
A23	LG 4261R 0023A	ARM ASSY	FIL		
A24	LG 4510R 0046A	LEVER	ASSY SWITCH		
001	LG 6723R D312A	DRUM(CIRC) ASSEMBLY			NSP
002	LG 4680R B005A	MOTOR(MECH)	DRUM I20AL05 SEJIN SANKYO ICLE		
002A	LG 5202R00002C	BRUSH,CARBON	ASSY D33 (TIP+2 SPRING) 1.4,		
003	LG 4930R 0294A	HOLDER,SHELF	FPC(RCH)		
004	LG 5006R 0034A	CAP	FPC		
006	LG 4580R 0004A	ROLLER	CLEANER		
007	LG 4260R 0039A	ARM	CLEANER		
008	LG 6850R HG18Z	CABLE,FLAT	P=1.25 FFC UL2896(0.05X0.8) 7		
009	LG 4260R 0038A	ARM	TU/P(D35)		
011	LG 4261R 0022A	ARM ASSY	TENSION(D35)		
012	LG 3041R 0037A	BASE ASSY	P2		
013	LG 3041R 0038A	BASE ASSY	P3		
014	LG 3041R 0039A	BASE ASSY	P4		
015	LG 5870R 0005A	OPENER	LID(D35)		
016	LG 3041R 0036A	BASE ASSEMBLY	A/C HEAD (ALPS)		
017	LG 4408R 0003A	REEL	S		
019	LG 4421R 0008A	BRAKE ASSEMBLY	RS		
020	LG 4970R 0128A	SPRING	COIL D35 (TB)		
021	LG 4421R 0006A	BRAKE ASSY	T		
022	LG 6520D00001A	HEAD(CIRC)	D35 FE TDK FE HEAD		
023	LG 3040R 0057A	BASE	LOADING		
024	LG 4261R 0029A	ARM ASSEMBLY	IDLER (N)		
025	LG 4810R 0111A	BRACKET	LID		NSP
026	LG 4680R D006A	MOTOR(MECH)	LOADING RF 370CA 12560 MABUCHI		NSP
027	LG 4470R 0093A	GEAR	WHEEL		NSP
028	LG 4408R 0004A	REEL	T		
029	LG 4261R 0019A	ARM ASSY	PINCH		
030	LG 4510R 0043A	LEVER	TU/P		
031	LG 4970R 0123A	SPRING	COIL TENSION(D35)		
032	LG 3141R 0040A	CHASSIS ASSY	D35		NSP
051	LG 4400R 0005A	BELT	CAPSTAN		
052A	LG 4980R 0023A	SUPPORTER	CAPSTAN(D35)		

#	REF No.	PART No.	PART NAME, DESCRIPTION	SPECIFICATION	NSP
054	LG 4470R 0100A	GEAR	RACK F/L		
054A	LG 4970R 0124B	SPRING	COIL D35 (RACK F/L)		
055	LG 4470R 0097A	GEAR	DRIVE(D35)		
056	LG 4470R 0096A	GEAR	CAM(D35)		
058	LG 4421R 0007A	BRAKE ASSY	CAPSTAN		
060	LG 4510R 0040A	LEVER	FR(D35)		
061	LG 4265R 0006A	CLUTCH ASSEMBLY	D35 (N)		
064	LG 4470R 0098A	GEAR	SECTOR(D35)		
065	LG 4261R 0021A	ARM ASSY	P3		NSP
066	LG 4970R 0122A	SPRING	COIL D35		NSP
067	LG 4470R 0095A	GEAR	P3		NSP
068	LG 4470R 0094A	GEAR	P2		NSP
069	LG 4970R 0122A	SPRING	COIL D35		NSP
070	LG 4261R 0020A	ARM ASSY	P2		NSP
076	LG 4510R 0047A	LEVER	SPRING		
077	LG 3300R M116A	PLATE	SLIDER		
078	LG 4510R 0041A	LEVER	TENSION		
079	LG 3040R 0056A	BASE	TENSION(D35)		
100	LG 3300R M118A	PLATE	TOP(D35)		
102	LG 4970R 0130A	SPRING	COIL D35 (STOPPER)		
103	LG 4930R 0276A	HOLDER,SHELF	SIDE(L)		NSP
105	LG 4930R 0274A	HOLDER,SHELF	CST		NSP
106	LG 4930R 0275A	HOLDER,SHELF	SIDE(R)		NSP
107	LG 4510R 0044A	LEVER	STOPPER		NSP
109	LG 5870R 0004A	OPENER	DOOR		
110	LG 4260R 0035A	ARM	FIL(L)		NSP
112	LG 3070R 0002A	BODY	FIL		NSP
113	LG 4970R 0127A	SPRING	COIL D35 (F/L(R))		NSP
114	LG 4260R 0036A	ARM	FIL(R)		NSP
115	LG 4510R 0042A	LEVER	SWITCH		
116	LG 4970R 0138A	SPRING	COIL D35 SWITCH		
117	LG 3300R M137A	PLATE	SPRING CST		
401	LG 1MEC0261518	SCREW MACHINE,PAN HEAD SPR W	D2.6 L4.5 MSWR3/FZY		
402	LG 1MPC0261418	SCREW MACHINE,PAN HEAD	D 2.6 L 4.0 MSWR3/FZY		
405	LG 1SZZR 0031B	SCREW,DRAWING	+ 1 D2.6 L5.8 SWRCH16A/FZY TAP		
406	LG 1MEC0302018	PAN HEAD MACHINE SCREW S/W +	D 3.0 L 6.0 MSWR3/FZY		
409	LG 1SZZR 0032B	SCREW,DRAWING	+ 1 D2.6 L5.0 SWRCH18A/FZY TAP		
410	LG 1APF0262218	SCREW TAP TITE(B),PAN HEAD	D2.6 L6.8 MSWR3/FZY		
504	LG 1WZZR 0004A	WASHER	STOPPER		
517	LG 1WZZR 0004D	WASHER	STOPPER		

MECHANISM ASSEMBLY(DVD) <MN>

A01	LG 4861R 0006A	CLAMP ASSY	DISC(DP2)		
A02	LG 3041R 0056A	BASE ASSEMBLY	MAIN(DP 4R, VCR)		
A03	LG 3041R 0054E	BASE ASSEMBLY	SLED (DP 5RM, 2LD 302T DC W/O		
A26	LG 6721R 0363A	DECK ASSEMBLY,VIDEO	DP5 4V(DVD VCR)		
001	LG 3300R 0547A	PLATE	CLAMP		NSP
002	LG 5016H 1016B	MAGNET	CLAMP(LDM R608,10*5,1*1.5T)		NSP
003	LG 4860R 0006A	CLAMP	UPPER		NSP
004	LG 4930R 0171A	HOLDER	CLAMP		
008	LG 4470R 0047A	GEAR	ASSY RACK		
009	LG 4470R 0053A	GEAR	MIDDLE		
010	LG 6850R GK22Z	CABLE,FLAT	P=1.0 FFC UL2896(0.05X0.65) 11		
011	LG 3210R 0036A	FRAME	UP/D		
011A	LG 6850R JW16B	CABLE,FLAT	P=1.0 FFC UL2896(0.035X0.7) 23		
012	LG 5040R 0047A	RUBBER	REAR(E2,5040H 1054A),YAMAUCHI		
013	LG 4400R 0006A	BELT	LOADING		
014	LG 4470R 0055A	GEAR	PULLLEY		
015	LG 6871R 4415A	PWB(PCB) ASSY,TOTAL	LOADING DP4		
016	LG 4470R 0050A	GEAR	ASSY FEED		
017	LG 4470R 0056A	GEAR	LOADING		
018	LG 4974R 0023A	GUIDE	UP/DOWN		
020	LG 3040R 0024A	BASE	MAIN		NSP
026	LG 3390R 0005A	TRAY	DISC		
429	LG 1SZZR 0012A	SCREW,	B TITE		
430	LG 1SZZH 1003A	SCREW,	+ D2.0 6MM SWRCH16A/NIY 4.5MM		
431	LG 1SZZH 1007B	SCREW,DRAWING	+ D2.0 6MM SWRCH16A/ZNBK 4MM 1		
432	LG 1SZZR 0011A	SCREW,	MACHINE		

*NSP : Not service parts

#	REF No.	PART No.	PART NAME, DESCRIPTION	SPECIFICATION	NSP	#	REF No.	PART No.	PART NAME, DESCRIPTION	SPECIFICATION	NSP

MAIN BOARD ASSEMBLY <03>											
A46	LG 3501R	4938W	BOARD ASSEMBLY	MAIN DCJK503WQ		C348	LG 0CN1040K948		CAPACITOR, FIXED TUBULAR(High d	0.1UF D 50V 80%, 20% F(Y5V) TA	
BD01	LG 636	004C	COIL	BEAD CORE BFS3550R2FD8,R T/P		C349	LG 0CN223AK948		CAPACITOR, TUBULAR(HIGH DIELEC	0.022UF 50V Z F TA26 S	
BD02	LG 636	004C	COIL	BEAD CORE BFS3550R2FD8,R T/P		C350	QETC1HM 106Z		CAPACITOR, ELECTROLYTIC	1.0M SRA/SS50V M FM5 TP(5)	
BD03	LG 874	000T	WIRE COPPER TIN COATED	D=0.6 ROLL		C351	LG 0CN1040K948		CAPACITOR, FIXED TUBULAR(High d	0.1UF D 50V 80%, 20% F(Y5V) TA	
BD101	S1WB/A/60	4101	DIODE	S1WBA60(1A 600V) SHIDENKEN		C352	QETC1HM 225Z		CAPACITOR, FIXED ELECTROLYTIC	2.2UF SRA,SS 50V 20% FM5 TP 5	
C101	LG 624	088H	CAPACITOR	PCX2 0.1UF/275VAC R T/P		C353	LG 0CN1030F678		CAPACITOR TUBULA(HIGH DIELE)	0.01M 16V M Y TA26	
C102	LG 624	088H	CAPACITOR	PCX2 0.1UF/275VAC R T/P		C354	LG 0CQ2232L559		CAPACITOR, POLYESTER	0.022UF S 63V K PP NI TP5	
C103	LG 624	082C	CAPACITOR, AL.ELECTROLYTIC	100MF/400V SHL SMPS SY		C356	LG 0CE3344K638		CAPACITOR, ELECTROLYTIC	0.33M SRA 50V M FM5 TP(5)	
C105	LG 0CQ1031Y519		CAPACITOR, POLYESTER	0.01UF D 630V K PE NI TP		C357	LG 0CN3330K518		CAPACITOR, FIXED TUBULAR(High d	0.033UF 50V K B TA26	
C106	LG 624	087G	CAPACITOR	HIGH VOL.68PF/1KV SMPS SAMHWA		C358	QETF1HM 335Z		CAPACITOR, FIXED ELECTROLYTIC	3.3UF SRA,SS 50V 20% FM5 TP 5	
C107	QETC1HM 106Z		CAPACITOR, ELECTROLYTIC	1.0M SRA/SS50V M FM5 TP(5)		C359	QET61CM 106Z		CAPACITOR, ELECTROLYTIC	10M SRA 16V M FM5 TP(5)	
C108	LG 0CE336B638		CAPACITOR, ELECTROLYTIC	33UF KME 25V M FM5 TP5		C360	LG 0CN1030F678		CAPACITOR TUBULA(HIGH DIELE)	0.01M 16V M Y TA26	
C109	LG 0CN223AK948		CAPACITOR, TUBULAR(HIGH DIELEC)	0.022UF 50V Z F TA26 S		C361	LG 0CN1030F678		CAPACITOR TUBULA(HIGH DIELE)	0.01M 16V M Y TA26	
C110	LG 0CG2210U610		CAPACITOR, SEMI CERAMIC	220 PF 400V M B R(NK,AD,SD)		C362	LG 0CN1030F678		CAPACITOR TUBULA(HIGH DIELE)	0.01M 16V M Y TA26	
C111	LG 0CG3320U630		CAPACITOR, SEMI CERAMIC	3300 PF 400V M E R(NK,AD,SD)		C363	LG 0CN1030F678		CAPACITOR TUBULA(HIGH DIELE)	0.01M 16V M Y TA26	
C121	LG 0CE2276F638		CAPACITOR, ELECTROLYTIC	220U SMS 16V M FM5 TP(5)		C365	QET61CM 476		CAPACITOR, ELECTROLYTIC	47M SRA/SS 16V M FM5 TP(5)	
C122	LG 624	085D	CAPACITOR	CE 47UF/50V KME (SMPS)		C366	LG 0CN1030F678		CAPACITOR TUBULA(HIGH DIELE)	0.01M 16V M Y TA26	
C123	LG 0CE477B638		CAPACITOR, ELECTROLYTIC	470UF KME 25V M FM5 TP5		C367	LG 0CN1030F678		CAPACITOR TUBULA(HIGH DIELE)	0.01M 16V M Y TA26	
C126	LG 0CE2276F638		CAPACITOR, FIXED ELECTROLYTIC	220UF SMS,SG 25V 20% FM5 TP 5		C368	LG 0CN1030F678		CAPACITOR TUBULA(HIGH DIELE)	0.01M 16V M Y TA26	
C127	LG 0CE108B638		CAPACITOR, FIXED ELECTROLYTIC	1000UF KME TYPE 16V M FM5 TP 5		C369	LG 0CN1030F678		CAPACITOR TUBULA(HIGH DIELE)	0.01M 16V M Y TA26	
C128	LG 0CE3376D638		CAPACITOR, ELECTROLYTIC	330UF SMS 10V M FM5 TP5		C370	LG 0CE4754K638		CAPACITOR, FIXED ELECTROLYTIC	4.7UF SRA,SS 50V 20% FM5 TP 5	
C129	LG 0CE228B630		CAPACITOR, FIXED ELECTROLYTIC	2200UF KME TYPE 16V 20% FM5 BU		C371	LG 0CN6810K518		CAPACITOR TUBULA(HIGH DIELE)	680P 50V K B TA26	
C130	LG 624	085D	CAPACITOR	CE 47UF/50V KME (SMPS)		C372	LG 0CX2700K408		CAPACITOR TUBULA(T.C)	27P 50V J SL TA26	
C131	LG 624	082H	CAPACITOR	CE 1000UF/10V SHL(10*12.5)T/P		C380	QETC1HM 106Z		CAPACITOR, ELECTROLYTIC	1.0M SRA/SS50V M FM5 TP(5)	
C132	LG 624	085D	CAPACITOR	CE 47UF/50V KME (SMPS)		C383	QETC1HM 106Z		CAPACITOR, ELECTROLYTIC	1.0M SRA/SS50V M FM5 TP(5)	
C133	LG 0CQ1042K409		CAPACITOR, FIXED FILM	0.1UF S 50V J PE TP		C383	QETC1HM 106Z		CAPACITOR, ELECTROLYTIC	1.0M SRA/SS50V M FM5 TP(5)	
C151	LG 0CE4754K638		CAPACITOR, FIXED ELECTROLYTIC	4.7UF SRA,SS 50V 20% FM5 TP 5		C383	QETC1HM 106Z		CAPACITOR, ELECTROLYTIC	1.0M SRA/SS50V M FM5 TP(5)	
C152	LG 0CE4754K638		CAPACITOR, FIXED ELECTROLYTIC	4.7UF SRA,SS 50V 20% FM5 TP 5		C383	QETC1HM 106Z		CAPACITOR, ELECTROLYTIC	1.0M SRA/SS50V M FM5 TP(5)	
C153	QET61CM 106Z		CAPACITOR, ELECTROLYTIC	10M SRA 16V M FM5 TP(5)		C383	QETC1HM 106Z		CAPACITOR, ELECTROLYTIC	1.0M SRA/SS50V M FM5 TP(5)	
C154	QET61CM 107Z		CAPACITOR, ELECTROLYTIC	100U SRA 16V M FM5 TP(5)		C383	QETC1HM 106Z		CAPACITOR, ELECTROLYTIC	1.0M SRA/SS50V M FM5 TP(5)	
C155	QET61CM 106Z		CAPACITOR, ELECTROLYTIC	10M SRA 16V M FM5 TP(5)		C383	QETC1HM 106Z		CAPACITOR, ELECTROLYTIC	1.0M SRA/SS50V M FM5 TP(5)	
C156	QET61CM 106Z		CAPACITOR, ELECTROLYTIC	10M SRA 16V M FM5 TP(5)		C383	QETC1HM 106Z		CAPACITOR, ELECTROLYTIC	1.0M SRA/SS50V M FM5 TP(5)	
C158	QET61CM 106Z		CAPACITOR, ELECTROLYTIC	10M SRA 16V M FM5 TP(5)		C383	QETC1HM 106Z		CAPACITOR, ELECTROLYTIC	1.0M SRA/SS50V M FM5 TP(5)	
C159	QET61CM 106Z		CAPACITOR, ELECTROLYTIC	10M SRA 16V M FM5 TP(5)		C383	QETC1HM 106Z		CAPACITOR, ELECTROLYTIC	1.0M SRA/SS50V M FM5 TP(5)	
C161	LG 0CE4764C638		CAPACITOR, ELECTROLYTIC	47M SRA 6.3V M FM5 TP(5)		C383	QETC1HM 106Z		CAPACITOR, ELECTROLYTIC	1.0M SRA/SS50V M FM5 TP(5)	
C162	LG 0CE4754K638		CAPACITOR, FIXED ELECTROLYTIC	4.7UF SRA,SS 50V 20% FM5 TP 5		C383	QETC1HM 106Z		CAPACITOR, ELECTROLYTIC	1.0M SRA/SS50V M FM5 TP(5)	
C163	LG 624	087H	CAPACITOR	HIGH VOL.220PF/1KV CERAMIC		C383	QETC1HM 106Z		CAPACITOR, ELECTROLYTIC	1.0M SRA/SS50V M FM5 TP(5)	
C172	LG 0CE4754K638		CAPACITOR, FIXED ELECTROLYTIC	4.7UF SRA,SS 50V 20% FM5 TP 5		C383	QETC1HM 106Z		CAPACITOR, ELECTROLYTIC	1.0M SRA/SS50V M FM5 TP(5)	
C301	LG 0CN1230K518		CAPACITOR, FIXED TUBULAR(High d	0.012UF D 50V 10% B(Y5P) TA26		C383	QETC1HM 106Z		CAPACITOR, ELECTROLYTIC	1.0M SRA/SS50V M FM5 TP(5)	
C302	QET61CM 226		CAPACITOR, ELECTROLYTIC	22M SRA 16V M FM5 TP(5)		C383	QETC1HM 106Z		CAPACITOR, ELECTROLYTIC	1.0M SRA/SS50V M FM5 TP(5)	
C303	LG 0CN1220F668		CAPACITOR TUBULA(HIGH DIELE)	1200P 16V M X TA26		C383	QETC1HM 106Z		CAPACITOR, ELECTROLYTIC	1.0M SRA/SS50V M FM5 TP(5)	
C304	LG 0CE4754K638		CAPACITOR, FIXED ELECTROLYTIC	4.7UF SRA,SS 50V 20% FM5 TP 5		C383	QETC1HM 106Z		CAPACITOR, ELECTROLYTIC	1.0M SRA/SS50V M FM5 TP(5)	
C305	LG 0CN2220F668		CAPACITOR, TUBULAR(HIGH DIELEC)	2200P 16V M X TA26		C383	QETC1HM 106Z		CAPACITOR, ELECTROLYTIC	1.0M SRA/SS50V M FM5 TP(5)	
C306	LG 0CE4754K638		CAPACITOR, FIXED ELECTROLYTIC	4.7UF SRA,SS 50V 20% FM5 TP 5		C383	QETC1HM 106Z		CAPACITOR, ELECTROLYTIC	1.0M SRA/SS50V M FM5 TP(5)	
C307	QET61CM 106Z		CAPACITOR, ELECTROLYTIC	10M SRA 16V M FM5 TP(5)		C383	QETC1HM 106Z		CAPACITOR, ELECTROLYTIC	1.0M SRA/SS50V M FM5 TP(5)	
C310	LG 0CN1040K948		CAPACITOR, FIXED TUBULAR(High d	0.1UF D 50V 80%, 20% F(Y5V) TA		C383	QETC1HM 106Z		CAPACITOR, ELECTROLYTIC	1.0M SRA/SS50V M FM5 TP(5)	
C311	QET61CM 106Z		CAPACITOR, ELECTROLYTIC	10M SRA 16V M FM5 TP(5)		C383	QETC1HM 106Z		CAPACITOR, ELECTROLYTIC	1.0M SRA/SS50V M FM5 TP(5)	
C313	LG 0CQ1032K409		CAPACITOR, POLYESTER(MYLAR)	0.01UF S 50V J PE TP		C383	QETC1HM 106Z		CAPACITOR, ELECTROLYTIC	1.0M SRA/SS50V M FM5 TP(5)	
C314	LG 0CQ3332K409		CAPACITOR, FIXED FILM	0.033UF S 50V J PE TP		C383	QETC1HM 106Z		CAPACITOR, ELECTROLYTIC	1.0M SRA/SS50V M FM5 TP(5)	
C315	QET61CM 476		CAPACITOR, ELECTROLYTIC	47M SRA/SS 16V M FM5 TP(5)		C383	QETC1HM 106Z		CAPACITOR, ELECTROLYTIC	1.0M SRA/SS50V M FM5 TP(5)	
C317	QET61CM 106Z		CAPACITOR, ELECTROLYTIC	10M SRA 16V M FM5 TP(5)		C383	QETC1HM 106Z		CAPACITOR, ELECTROLYTIC	1.0M SRA/SS50V M FM5 TP(5)	
C318	LG 0CN1510K518		CAPACITOR TUBULA(HIGH DIELE)	150P 50V K B TA26		C383	QETC1HM 106Z		CAPACITOR, ELECTROLYTIC	1.0M SRA/SS50V M FM5 TP(5)	
C319	LG 0CN1040K948		CAPACITOR, FIXED TUBULAR(High d	0.1UF D 50V 80%, 20% F(Y5V) TA		C383	QETC1HM 106Z		CAPACITOR, ELECTROLYTIC	1.0M SRA/SS50V M FM5 TP(5)	
C320	QET61CM 106Z		CAPACITOR, ELECTROLYTIC	10M SRA 16V M FM5 TP(5)		C383	QETC1HM 106Z		CAPACITOR, ELECTROLYTIC	1.0M SRA/SS50V M FM5 TP(5)	
C321	LG 0CX4700K408		CAPACITOR TUBULA(T.C)	47P 50V J SL TA26		C383	QETC1HM 106Z		CAPACITOR, ELECTROLYTIC	1.0M SRA/SS50V M FM5 TP(5)	
C322	LG 0CN1040K948		CAPACITOR, FIXED TUBULAR(High d	0.1UF D 50V 80%, 20% F(Y5V) TA		C383	QETC1HM 106Z		CAPACITOR, ELECTROLYTIC	1.0M SRA/SS50V M FM5 TP(5)	
C323	LG 0CN1040K948		CAPACITOR, FIXED TUBULAR(High d	0.1UF D 50V 80%, 20% F(Y5V) TA		C383	QETC1HM 106Z		CAPACITOR, ELECTROLYTIC	1.0M SRA/SS50V M FM5 TP(5)	
C324	QET61CM 106Z		CAPACITOR, ELECTROLYTIC	10M SRA 16V M FM5 TP(5)		C383	QETC1HM 106Z		CAPACITOR, ELECTROLYTIC	1.0M SRA/SS50V M FM5 TP(5)	
C325	LG 0CN1040K948		CAPACITOR, FIXED TUBULAR(High d	0.1UF D 50V 80%, 20% F(Y5V) TA		C383	QETC1HM 106Z		CAPACITOR, ELECTROLYTIC	1.0M SRA/SS50V M FM5 TP(5)	
C326	LG 0CN1040K948		CAPACITOR, FIXED TUBULAR(High d	0.1UF D 50V 80%, 20% F(Y5V) TA		C383	QETC1HM 106Z		CAPACITOR, ELECTROLYTIC	1.0M SRA/SS50V M FM5 TP(5)	
C327	QETF1HM 335Z		CAPACITOR, FIXED ELECTROLYTIC	3.3UF SRA,SS 50V 20% FM5 TP 5		C383	QETC1HM 106Z		CAPACITOR, ELECTROLYTIC	1.0M SRA/SS50V M FM5 TP(5)	
C328	QET61CM 106Z		CAPACITOR, ELECTROLYTIC	10M SRA 16V M FM5 TP(5)		C383	QETC1HM 106Z		CAPACITOR, ELECTROLYTIC	1.0M SRA/SS50V M FM5 TP(5)	
C330	QETC1HM 225Z		CAPACITOR, FIXED ELECTROLYTIC	2.2UF SRA,SS 50V 20% FM5 TP 5		C383	QETC1HM 106Z		CAPACITOR, ELECTROLYTIC	1.0M SRA/SS50V M FM5 TP(5)	
C331	QETC1HM 106Z		CAPACITOR, ELECTROLYTIC	1.0M SRA/SS50V M FM5 TP(5)		C383	QETC1HM 106Z		CAPACITOR, ELECTROLYTIC	1.0M SRA/SS50V M FM5 TP(5)	
C333	LG 0CN3310K518		CAPACITOR TUBULA(HIGH DIELE)	330P 50V K B TA26		C383	QETC1HM 106Z		CAPACITOR, ELECTROLYTIC	1.0M SRA/SS50V M FM5 TP(5)	
C334	LG 0CN4730K948		CAPACITOR, FIXED TUBULAR(High d	0.047UF D 50V 80%, 20% F(Y5V)		C383	QETC1HM 106Z		CAPACITOR, ELECTROLYTIC	1.0M SRA/SS50V M FM5 TP(5)	
C335	QET61CM 106Z		CAPACITOR, ELECTROLYTIC	10M SRA 16V M FM5 TP(5)		C383	QETC1HM 106Z		CAPACITOR, ELECTROLYTIC	1.0M SRA/SS50V M FM5 TP(5)	
C336	LG 0CN1030F678		CAPACITOR TUBULA(HIGH DIELE)	0.01M 16V M Y TA26		C383	QETC1HM 106Z		CAPACITOR, ELECTROLYTIC	1.0M SRA/SS50V M FM5 TP(5)	
C337	LG 0CN1040K948		CAPACITOR, FIXED TUBULAR(High d	0.1UF D 50V 80%, 20% F(Y5V) TA		C383	QETC1HM 106Z		CAPACITOR, ELECTROLYTIC	1.0M SRA/SS50V M FM5 TP(5)	
C338	LG 0CN1030F678		CAPACITOR TUBULA(HIGH DIELE)	0.01M 16V M Y TA26		C383	QETC1HM 106Z		CAPACITOR, ELECTROLYTIC	1.0M SRA/SS50V M FM5 TP(5)	
C339	LG 0CN1040K948		CAPACITOR, FIXED TUBULAR(High d	0.1UF D 50V 80%, 20% F(Y5V) TA		C383	QETC1HM 106Z		CAPACITOR, ELECTROLYTIC	1.0M SRA/SS50V M FM5 TP(5)	
C340	LG 0CN1030F678		CAPACITOR TUBULA(HIGH DIELE)	0.01M 16V M Y TA26		C383	QETC1HM 106Z		CAPACITOR, ELECTROLYTIC	1.0M SRA/SS50V M FM5 TP(5)	
C341	LG 0CN1030F678		CAPACITOR TUBULA(HIGH DIELE)	0.01M 16V M Y TA26		C383	QETC1HM 106Z		CAPACITOR, ELECTROLYTIC	1.0M SRA/SS50V M FM5 TP(5)	
C342	QET61CM 476		CAPACITOR, ELECTROLYTIC	47M SRA/SS 16V M FM5 TP(5)		C383	QETC1HM 106Z		CAPACITOR, ELECTROLYTIC	1.0M SRA/SS50V M FM5 TP(5)	
C344	LG 0CN223AK948		CAPACITOR, TUBULAR(HIGH DIELEC)	0.022UF 50V Z F TA26 S		C383	QETC1HM 106Z		CAPACITOR, ELECTROLYTIC	1.0M SRA/SS50V M FM5 TP(5)	
C345	LG 0CE4754K638		CAPACITOR, FIXED ELECTROLYTIC	4.7UF SRA,SS 50V 20% FM5 TP 5		C383	QETC1HM 106Z		CAPACITOR, ELECTROLYTIC	1.0M SRA/SS50V M FM5 TP(5)	
C346	LG 0CC0500K015		CAPACITOR, CERAMIC(TEMP COMPE	5P 50V C NPO TR		C383	QETC1HM 106Z		CAPACITOR, ELECTROLYTIC	1.0M SRA/SS50V M FM5 TP(5)	
C347	LG 0CE4754K638		CAPACITOR, FIXED ELECTROLYTIC	4.7UF SRA,SS 50V 20% FM5 TP 5		C383	QETC1HM 106Z		CAPACITOR, ELECTROLYTIC	1.0M SRA/SS50V M FM5 TP(5)	
C348	LG 0CN1040K948		CAPACITOR, FIXED TUBULAR(High d	0.1UF D 50V 80%, 20% F(Y5V) TA		C383	QETC1HM 106Z		CAPACITOR,		

*NSP : Not service parts

#	REF No.	PART No.	PART NAME, DESCRIPTION	SPECIFICATION	NSP	#	REF No.	PART No.	PART NAME, DESCRIPTION	SPECIFICATION	NSP
C534	LG	0CE4754K638	CAPACITOR, FIXED ELECTROLYTIC	4.7UF SRA,SS 50V 20% FM5 TP 5		D114	LG	ODR104009AB	DIODE, RECTIFIER	RL104 R. TP GULF SEMICONDUCTOR	
C535	LG	0CE4754K638	CAPACITOR, FIXED ELECTROLYTIC	4.7UF SRA,SS 50V 20% FM5 TP 5		D117	LG	ODR104009AB	DIODE, RECTIFIER	RL104 R. TP GULF SEMICONDUCTOR	
C541	LG	0CE4754K638	CAPACITOR, FIXED ELECTROLYTIC	4.7UF SRA,SS 50V 20% FM5 TP 5		D121	1S5133 T2		DIODE, SWITCHING	1S5133 DETECT, SW TP	
C542	LG	0CN6810K518	CAPACITOR TUBULAR(HIGH DIELE)	680P 50V K B TA26		D122	1S5133 T2		DIODE, SWITCHING	1S5133 DETECT, SW TP	
C543	LG	0CN223AK948	CAPACITOR, TUBULAR(HIGH DIELEC)	0.022UF 50V Z F TA26 S		D502	1S5133 T2		DIODE, SWITCHING	1S5133 DETECT, SW TP	
C544	LG	0CN4730K948	CAPACITOR, FIXED TUBULAR(HIGH d	0.047UF D 50V 80%, 20% F(Y5V)		D509	1S5133 T2		DIODE, SWITCHING	1S5133 DETECT, SW TP	
C546	LG	0CN223AK948	CAPACITOR, TUBULAR(HIGH DIELEC)	0.022UF 50V Z F TA26 S		D801	1S5133 T2		DIODE, SWITCHING	1S5133 DETECT, SW TP	
C551	LG	0CN223AK948	CAPACITOR, TUBULAR(HIGH DIELEC)	0.022UF 50V Z F TA26 S		D803	1S5133 T2		DIODE, SWITCHING	1S5133 DETECT, SW TP	
C552	LG	0CN1030F678	CAPACITOR TUBULA(HIGH DIELE)	0.01M 16V M Y TA26		E5501	LG	4931R 0050A	HOLDER ASSY	END	
C556	LG	0CN1030F678	CAPACITOR TUBULA(HIGH DIELE)	0.01M 16V M Y TA26		E5502	LG	4931R 0050A	HOLDER ASSY	END	
C557	LG	0CN1030F678	CAPACITOR TUBULA(HIGH DIELE)	0.01M 16V M Y TA26		F101	LG	585 011T	FUSE, SLOW BLOW	1600MA 250 V 5.2X20 CY/GL SEMK	
C561	QET61CM	106Z	CAPACITOR, ELECTROLYTIC	10M SRA 16V M FM5 TP(5)		F102	LG	GIRH200000B	IC, ROHM	ICP N20 T104 TP IC DETACT	
C564	LG	0CN3310K518	CAPACITOR TUBULAR(HIGH DIELE)	330P 50V K B TA26		FL301	LG	633 032N	COIL, IFT	BIAC OSC DEO 010 KWANGSUNG	
C567	LG	0CN1020K518	CAPACITOR TUBULA(HIGH DIELE)	1000P 50V K B TA26		IC101	LG	0IPMGFF001A	IC, POWER MANAGEMENT	ICE28265 INFINEON 8 DIP ST SMP	
C570	LG	0CC1500K415	CAPACITOR, CERAMIC(TEMP COMP)	15P 50V JNPO TS		IC102	LG	0ISS431000A	IC, SAMSUNG ELECTRONICS	KA431AZ (LM431AZ)	
C571	LG	0CC1500K415	CAPACITOR, CERAMIC(TEMP COMP)	15P 50V JNPO TS		IC103	PQ3RD13		IC, SHARP	PQ3RD13L 4PIN TO 220 ST 3.3V L	
C574	LG	0CN1020K518	CAPACITOR TUBULA(HIGH DIELE)	1000P 50V K B TA26		IC104	PQ3RD13		IC, SHARP	PQ3RD13L 4PIN TO 220 ST 3.3V L	
C575	LG	0CN1020K518	CAPACITOR TUBULA(HIGH DIELE)	1000P 50V K B TA26		IC105	PZ0LL817000B		SENSOR	LTV 817B, PHOTO COUPLER(LITEON)	
C581	LG	0CN1030F678	CAPACITOR TUBULA(HIGH DIELE)	0.01M 16V M Y TA26		IC106	KI47808PI		IC, POWER MANAGEMENT	KI47808PI CU KEC 4P TO 220IS	
C582	LG	0CN1030F678	CAPACITOR TUBULA(HIGH DIELE)	0.01M 16V M Y TA26		IC301	LG	0IH118717B	IC, HITACHI	HA118717F 100QFP BK AVCP1CHIP	
C588	LG	0CE4754K638	CAPACITOR, FIXED ELECTROLYTIC	4.7UF SRA,SS 50V 20% FM5 TP 5		IC401	LG	0IM658450A	IC, MITSUBISHI	M65845AFP 36DIP BK KARAOKE	
C591	LG	0CE4764H638	CAPACITOR, FIXED ELECTROLYTIC	47M SRA 25V M FM5 TP(5)		IC403	LG	0IM624290A	IC, MITSUBISHI	M62429P 8DIP BK DIP	
C596	LG	0CN223AK948	CAPACITOR, TUBULAR(HIGH DIELEC)	0.022UF 50V Z F TA26 S		IC405	NUM4580D		IC, PERIPHERALS	NUM4580D JRC 8 DIP ST SWITCHIN	
C804	LG	0CE4754K638	CAPACITOR, FIXED ELECTROLYTIC	4.7UF SRA,SS 50V 20% FM5 TP 5		IC501	LG	0IMCRHY065B	IC, MICRO CONTROLLER	GMS3977RBB70F HYNIX 100PIN QFP	
C805	LG	0CE4754K638	CAPACITOR, FIXED ELECTROLYTIC	4.7UF SRA,SS 50V 20% FM5 TP 5		IC504	LG	0IKET703100A	IC, KEC	KI47031P 3P 3.1V RESET(TAPING)	
C806	QET61CM	106Z	CAPACITOR, ELECTROLYTIC	10M SRA 16V M FM5 TP(5)		IC801	LG	0IPH960500A	IC, PHILIPS	TD49605H QFP44 BK HIFI AMP+HIF	
C808	QET61CM	106Z	CAPACITOR, ELECTROLYTIC	10M SRA 16V M FM5 TP(5)		IC802	MM1443XJ		IC, MITSUBISHI	MM1443XJ S50P 34 TP CANAL S/W	
C809	QET61CM	106Z	CAPACITOR, ELECTROLYTIC	10M SRA 16V M FM5 TP(5)		JK801	LG	6612R C012A	JACK, RCA	RCA 612 YUQIL 15X20, 6RCA	
C810	QET61CM	106Z	CAPACITOR, ELECTROLYTIC	10M SRA 16V M FM5 TP(5)		L102	LG	616 145E	FILTER(CIRC), DRAWING	KSE 145E KSE LINE FILTER S0211	
C811	LG	0CE4754K638	CAPACITOR, FIXED ELECTROLYTIC	4.7UF SRA,SS 50V 20% FM5 TP 5		L122	LG	633 088G	COIL, CHOKE	CHOCK(22MH) 5MM TOKO TP	
C812	QET61CM	106Z	CAPACITOR, ELECTROLYTIC	10M SRA 16V M FM5 TP(5)		L123	LG	633 088G	COIL, CHOKE	CHOCK(22MH) 5MM TOKO TP	
C813	LG	0CN6820F668	CAPACITOR, TUBULAR(HIGH DIELEC)	6800P 16V M X TA26		L124	LG	633 088G	COIL, CHOKE	CHOCK(22MH) 5MM TOKO TP	
C814	QET61CM	476	CAPACITOR, ELECTROLYTIC	47M SRA/SS 16V M FM5 TP(5)		L301	LG	0LR1000K035	INDUCTOR RADIAL LEAD	100M K 6X6 L5 TP	
C815	QET61CM	106Z	CAPACITOR, ELECTROLYTIC	10M SRA 16V M FM5 TP(5)		L303	LG	0LA1800K018	INDUCTOR AXIAL LEAD	180M K 2.3X3.4 L5 TP	
C816	QET61CM	106Z	CAPACITOR, ELECTROLYTIC	10M SRA 16V M FM5 TP(5)		L304	LG	0LR1000J025	INDUCTOR, RADIAL LEAD	100UH 5 4X5 TR5	
C817	QET61CM	106Z	CAPACITOR, ELECTROLYTIC	10M SRA 16V M FM5 TP(5)		L306	LG	0LA0122K018	INDUCTOR AXIAL LEAD	12M K 2.3X3.4 L5 TP	
C818	QET61CM	476	CAPACITOR, ELECTROLYTIC	47M SRA/SS 16V M FM5 TP(5)		L311	LG	0LA1000K018	INDUCTOR AXIAL LEAD	100M K 2.3X3.4 L5 TP	
C819	LG	0CN6820F668	CAPACITOR, TUBULAR(HIGH DIELEC)	6800P 16V M X TA26		L3S1	LG	0LA0332K018	INDUCTOR AXIAL LEAD	33M K 2.3X3.4 L5 TP	
C820	QET61CM	106Z	CAPACITOR, ELECTROLYTIC	10M SRA 16V M FM5 TP(5)		L401	LG	0LR1000J025	INDUCTOR, RADIAL LEAD	100UH 5 4X5 TR5	
C821	LG	0CN1030F678	CAPACITOR TUBULA(HIGH DIELE)	0.01M 16V M Y TA26		L402	LG	0LR1000J025	INDUCTOR, RADIAL LEAD	100UH 5 4X5 TR5	
C822	QET61CM	476	CAPACITOR, ELECTROLYTIC	47M SRA/SS 16V M FM5 TP(5)		L505	LG	0LR0102J0N5	INDUCTOR, RADIAL LEAD	10UH 5% TP 3X5 TR5	
C823	LG	0CN1040K948	CAPACITOR, FIXED TUBULAR(HIGH d	0.1UF D 50V 80%, 20% F(Y5V) TA		L506	LG	635 027C	INDUCTOR, RADIAL LEAD	EL04065RA SKH150G 3 K TDK 15UH	
C824	LG	0CN1030F678	CAPACITOR TUBULA(HIGH DIELE)	0.01M 16V M Y TA26		L801	LG	0LR1000J025	INDUCTOR, RADIAL LEAD	100UH 5 4X5 TR5	
C825	QET61CM	476	CAPACITOR, ELECTROLYTIC	47M SRA/SS 16V M FM5 TP(5)		L873	LG	0LA1000K018	INDUCTOR AXIAL LEAD	100M K 2.3X3.4 L5 TP	
C826	LG	0CN1030F678	CAPACITOR TUBULA(HIGH DIELE)	0.01M 16V M Y TA26		L874	LG	0LA1000K018	INDUCTOR AXIAL LEAD	100M K 2.3X3.4 L5 TP	
C827	LG	0CN1040K948	CAPACITOR, FIXED TUBULAR(HIGH d	0.1UF D 50V 80%, 20% F(Y5V) TA		LD501	LG	4931R 0017A	HOLDER ASSY	LED	
C848	LG	0CN1050K948	CAPACITOR, TUBULAR(HIGH DIELEC)	1UF 50V Z F TA26 D		MS501	LG	6600JB8005B	SWITCH, MODE	NON 5V 1MA VERTICAL G	
C849	LG	0CN1050K948	CAPACITOR, TUBULAR(HIGH DIELEC)	1UF 50V Z F TA26 D		P1D01	LG	6631R E007M	CONNECTOR ASSEMBLY	8283/9073 12 PIN 200MM UL1061	
C850	QET61CM	106Z	CAPACITOR, ELECTROLYTIC	10M SRA 16V M FM5 TP(5)		P3D01	LG	561 234S	CONNECTOR(CIRC), DRAWING	GF120 9S 1A LG CABLE 9P 1.25	
C852	QET61CM	106Z	CAPACITOR, ELECTROLYTIC	10M SRA 16V M FM5 TP(5)		P3D02	LG	6630R5S010A	CONNECTOR(CIRC)	GF105 06S TS LG CABLE 6PIN 2MM	
C854	QET61CM	106Z	CAPACITOR, ELECTROLYTIC	10M SRA 16V M FM5 TP(5)		P3D03	LG	561 251B	CONNECTOR(CIRC), DRAWING	GB201 2P TS B(LCG)	
C857	QET61CM	106Z	CAPACITOR, ELECTROLYTIC	10M SRA 16V M FM5 TP(5)		PRD01	LG	561 686L	CONNECTOR(CIRC), FFC/FPC	00 8370 121 000 800 ELCO 12PIN	
C859	QET61CM	226	CAPACITOR, ELECTROLYTIC	22M SRA 16V M FM5 TP(5)		PM401	LG	561 036D	CONNECTOR	MA V 8283 0512 WH ELCO	
C860	QET61CM	106Z	CAPACITOR, ELECTROLYTIC	10M SRA 16V M FM5 TP(5)		PM601	LG	6630R2P011L	CONNECTOR(CIRC), BOARD TO BOARD	GB202 12P TS LG CABLE 12PIN 2	
C861	QET61CM	106Z	CAPACITOR, ELECTROLYTIC	10M SRA 16V M FM5 TP(5)		PMC01	LG	6630R BE01L	CONNECTOR(CIRC), BOARD TO BOARD	JE612 12 JAE EUN 12P 2.0MM	
C863	QET61CM	476	CAPACITOR, ELECTROLYTIC	47M SRA/SS 16V M FM5 TP(5)		PW110	LG	561 292B	CONNECTOR	GP390 LGC 3P 3.96 STRAIGHT SN	
C864	QET61CM	105Z	CAPACITOR, ELECTROLYTIC	1.0M SRA/SS50V M FM5 TP(5)		Q110	LG	0TR320309AA	TRANSISTOR, BIPOLARS	KTC3203 KEC TP T092 50V 150MA	
C867	LG	0CE5600K408	CAPACITOR, TUBULAR(T.C)	56P 50V J SL TA26		Q111	KRA103M T		TRANSISTOR	KRA103M TP (KRA2203) KEC	
C868	LG	0CE4774C638	CAPACITOR, FIXED ELECTROLYTIC	470UF SRA,SS 6.3V 20% FM5 TP 5		Q112	LG	0TR320309AA	TRANSISTOR, BIPOLARS	KTC3203 KEC TP T092 50V 150MA	
C872	LG	0CN1020K518	CAPACITOR TUBULA(HIGH DIELE)	1000P 50V K B TA26		Q113	LG	0TR127309AA	TRANSISTOR	KTA1273 TP Y (KTA966A)KEC	
C874	LG	0CN1020K518	CAPACITOR TUBULA(HIGH DIELE)	1000P 50V K B TA26		Q114	LG	0TR126809BA	TRANSISTOR, BIPOLARS	KTA1268 BL TP KEC	
C876	LG	0CN1020K518	CAPACITOR TUBULA(HIGH DIELE)	1000P 50V K B TA26		Q115	KTC3199/L		TRANSISTOR, BIPOLARS	KTC3199 BL MINI TP KEC	
C877	LG	0CN1020K518	CAPACITOR TUBULA(HIGH DIELE)	1000P 50V K B TA26		Q116	LG	0TR127309AA	TRANSISTOR	KTA1273 TP Y (KTA966A)KEC	
C878	LG	0CN1020K518	CAPACITOR TUBULA(HIGH DIELE)	1000P 50V K B TA26		Q117	LG	0TR320509AB	TRANSISTOR	KTC3205 TP Y (KTC2236A)KEC	
C879	LG	0CN1020K518	CAPACITOR TUBULA(HIGH DIELE)	1000P 50V K B TA26		Q172	LG	0TR320309AA	TRANSISTOR, BIPOLARS	KTC3203 KEC TP T092 50V 150MA	
C881	QET61CM	106Z	CAPACITOR, ELECTROLYTIC	10M SRA 16V M FM5 TP(5)		Q301	LG	0TR320309AA	TRANSISTOR, BIPOLARS	KTC3203 KEC TP T092 50V 150MA	
C884	LG	0CE4754K638	CAPACITOR, FIXED ELECTROLYTIC	4.7UF SRA,SS 50V 20% FM5 TP 5		Q302	LG	0TR127309AA	TRANSISTOR	KTA1273 TP Y (KTA966A)KEC	
C885	LG	0CE4754K638	CAPACITOR, FIXED ELECTROLYTIC	4.7UF SRA,SS 50V 20% FM5 TP 5		Q303	KRC103M T		TRANSISTOR	KRC103M TP (KRC1203) KEC	
C886	LG	0CN223AK948	CAPACITOR, TUBULAR(HIGH DIELEC)	0.022UF 50V Z F TA26 S		Q304	KTA1267/G/		TRANSISTOR	KTA1267 GR MINI TP KEC	
C887	QET61CM	476	CAPACITOR, ELECTROLYTIC	47M SRA/SS 16V M FM5 TP(5)		Q305	KTC3199/L		TRANSISTOR, BIPOLARS	KTC3199 BL MINI TP KEC	
C888	QET61CM	105Z	CAPACITOR, ELECTROLYTIC	1.0M SRA/SS50V M FM5 TP(5)		Q306	KTC3199/L		TRANSISTOR, BIPOLARS	KTC3199 BL MINI TP KEC	
C889	QET61CM	105Z	CAPACITOR, ELECTROLYTIC	1.0M SRA/SS50V M FM5 TP(5)		Q307	KRA103M T		TRANSISTOR	KRA103M TP (KRA2203) KEC	
C890	LG	0CN4730K948	CAPACITOR, FIXED TUBULAR(HIGH d	0.047UF D 50V 80%, 20% F(Y5V)		Q309	KTA1267/G/		TRANSISTOR	KTA1267 GR MINI TP KEC	
C891	QET61CM	106Z	CAPACITOR, ELECTROLYTIC	10M SRA 16V M FM5 TP(5)		Q3S1	KTC3199/L		TRANSISTOR, BIPOLARS	KTC3199 BL MINI TP KEC	
CS501	LG	6600M000002	SWITCH, PUSH	MPU11810MLB0 MIC DC 5V 1MA D 3		Q501	KTC3199/L		TRANSISTOR, BIPOLARS	KTC3199 BL MINI TP KEC	
D101	ERA22 10		DIODE, RECTIFIERS	ERA22 10 KFLB, TP, R, T/P, F/LL		Q503	KTA1267/G/		TRANSISTOR	KTA1267 GR MINI TP KEC	
D102	LG	0DD010009AC	DIODE	EU01(W/R FORM) TP SANKEN		Q514	KRC103M T		TRANSISTOR	KRC103M TP (KRC1203) KEC	
D107	LG	0DD010009AC	DIODE	EU01(W/R FORM) TP SANKEN		Q515	KRC103M T		TRANSISTOR	KRC103M TP (KRC1203) KEC	
D108	LG	0DD010009AC	DIODE	EU01(W/R FORM) TP SANKEN		Q516	KRC103M T		TRANSISTOR	KRC103M TP (KRC1203) KEC	
D110	LG	0DD400000AD	DIODE, RECTIFIERS	RU4YXLF(015 30S) M20 SANKEN		Q517	KRC103M T		TRANSISTOR	KRC103M TP (KRC1203) KEC	
D111	LG	0DR158220AA	DIODE, RECTIFIER	1N5822 BK RECTRON D0201AD 40V		Q801	KTA1267/G/		TRANSISTOR	KTA1267 GR MINI TP KEC	
D112	LG	0DR158220AA	DIODE, RECTIFIER	1N5822 BK RECTRON D0201AD 40V		Q802	KTC3199/L		TRANSISTOR, BIPOLARS	KTC3199 BL MINI TP KEC	
D113	LG	0DD010009AC	DIODE	EU01(W/R FORM) TP SANKEN		Q803	KTC3199/L				

*NSP : Not service parts

#	REF No.	PART No.	PART NAME, DESCRIPTION	SPECIFICATION	NSP	#	REF No.	PART No.	PART NAME, DESCRIPTION	SPECIFICATION	NSP
R581	QRD161J 683Y		RESISTOR, FIXED CARBON FILM	68K OHM 1/6 W 5% TA26		IC601	LG 01PRPNE001A		IC, PERIPHERALS	UPD16315GB 3BS NEC 44 QFP BK F	
R582	QRE141J 123Y		RESISTOR, FIXED CARBON FILM	12K OHM 1/6 W 5% TA26		L601	LG 0LR8200J025		INDUCTOR, RADIAL LEAD	820UH 5% 4X5 TR5	
R583	QRD161J 563Y		RESISTOR, FIXED CARBON FILM	56K OHM 1/6 W 5% TA26		R601	QRE141J 102Y		RESISTOR, FIXED CARBON FILM	1K OHM 1/6 W 5% TA26	
R584	QRE141J 103Y		RESISTOR, FIXED CARBON FILM	10K OHM 1/6 W 5% TA26		R602	QRE141J 102Y		RESISTOR, FIXED CARBON FILM	1K OHM 1/6 W 5% TA26	
R588	QRD161J 222Y		RESISTOR, FIXED CARBON FILM	2.2K OHM 1/6 W 5% TA26		R603	QRE141J 102Y		RESISTOR, FIXED CARBON FILM	1K OHM 1/6 W 5% TA26	
R589	QRD161J 105Y		RESISTOR, FIXED CARBON FILM	1M OHM 1/6 W 5% TA26		R604	QRD161J 563Y		RESISTOR, FIXED CARBON FILM	56K OHM 1/6 W 5% TA26	
R5B1	QRE141J 102Y		RESISTOR, FIXED CARBON FILM	1K OHM 1/6 W 5% TA26		R605	QRE141J 331Y		RESISTOR, FIXED CARBON FILM	330 OHM 1/6 W 5% TA26	
R5B3	QRE141J 102Y		RESISTOR, FIXED CARBON FILM	1K OHM 1/6 W 5% TA26		R606	QRD161J 4R7Y		RESISTOR, FIXED CARBON FILM	4.7 OHM 1/6 W 5% TA26	
R5B4	QRE141J 102Y		RESISTOR, FIXED CARBON FILM	1K OHM 1/6 W 5% TA26		R607	QRD161J 4R7Y		RESISTOR, FIXED CARBON FILM	4.7 OHM 1/6 W 5% TA26	
R5B5	QRD161J 101Y		RESISTOR, FIXED CARBON FILM	100 OHM 1/6 W 5% TA26		R612	QRE141J 681Y		RESISTOR, FIXED CARBON FILM	680 OHM 1/6 W 5% TA26	
R5C5	QRE141J 102Y		RESISTOR, FIXED CARBON FILM	1K OHM 1/6 W 5% TA26		R613	QRD161J 821Y		RESISTOR, FIXED CARBON FILM	820 OHM 1/6 W 5% TA26	
R5C6	QRE141J 102Y		RESISTOR, FIXED CARBON FILM	1K OHM 1/6 W 5% TA26		R614	QRD161J 122		RESISTOR, FIXED CARBON FILM	1.2K OHM 1/6 W 5% TA26	
R5C7	QRE141J 102Y		RESISTOR, FIXED CARBON FILM	1K OHM 1/6 W 5% TA26		R615	QRE141J 152Y		RESISTOR, FIXED CARBON FILM	1.5K OHM 1/6 W 5% TA26	
R5C9	QRE141J 103Y		RESISTOR, FIXED CARBON FILM	10K OHM 1/6 W 5% TA26		R616	QRD161J 222Y		RESISTOR, FIXED CARBON FILM	2.2K OHM 1/6 W 5% TA26	
R5E7	QRE141J 103Y		RESISTOR, FIXED CARBON FILM	10K OHM 1/6 W 5% TA26		R617	QRD161J 332Y		RESISTOR, FIXED CARBON FILM	3.3K OHM 1/6 W 5% TA26	
R5E8	QRE141J 103Y		RESISTOR, FIXED CARBON FILM	10K OHM 1/6 W 5% TA26		R618	QRD161J 472Y		RESISTOR, FIXED CARBON FILM	4.7K OHM 1/6 W 5% TA26	
R601	QRD161J 335Y		RESISTOR, FIXED CARBON FILM	3.3M OHM 1/6 W 5% TA26		R619	QRD161J 822Y		RESISTOR, FIXED CARBON FILM	8.2K OHM 1/6 W 5% TA26	
R602	QRE141J 333Y		RESISTOR, FIXED CARBON FILM	33K OHM 1/6 W 5% TA26		R620	QRD161J 153Y		RESISTOR, FIXED CARBON FILM	15K OHM 1/6 W 5% TA26	
R603	QRD161J 272Y		RESISTOR, FIXED CARBON FILM	2.7K OHM 1/6 W 5% TA26		RC601	LG 6712R0838GA		REMOTE CONTROLLER RECEIVER	TSOP1238LIUQ1 VISHAY(TEMIC) 37 9	
R604	QRD161J 393Y		RESISTOR, FIXED CARBON FILM	39K OHM 1/6 W 5% TA26		SW601	LG 556 219B		SWITCH, TACT	THVV502GAA POSTECH DC 12 V 5	
R605	QRD161J 272Y		RESISTOR, FIXED CARBON FILM	2.7K OHM 1/6 W 5% TA26		SW602	LG 556 219B		SWITCH, TACT	THVV502GAA POSTECH DC 12 V 5	
R606	QRE141J 333Y		RESISTOR, FIXED CARBON FILM	33K OHM 1/6 W 5% TA26		SW603	LG 556 219B		SWITCH, TACT	THVV502GAA POSTECH DC 12 V 5	
R607	QRD161J 471Y		RESISTOR, FIXED CARBON FILM	470 OHM 1/6 W 5% TA26		SW604	LG 556 219B		SWITCH, TACT	THVV502GAA POSTECH DC 12 V 5	
R608	QRE141J 103Y		RESISTOR, FIXED CARBON FILM	10K OHM 1/6 W 5% TA26		SW605	LG 556 219B		SWITCH, TACT	THVV502GAA POSTECH DC 12 V 5	
R609	QRD161J 183Y		RESISTOR, FIXED CARBON FILM	18K OHM 1/6 W 5% TA26		SW606	LG 556 219B		SWITCH, TACT	THVV502GAA POSTECH DC 12 V 5	
R610	QRD161J 101Y		RESISTOR, FIXED CARBON FILM	100 OHM 1/6 W 5% TA26		SW607	LG 556 219B		SWITCH, TACT	THVV502GAA POSTECH DC 12 V 5	
R611	QRD161J 101Y		RESISTOR, FIXED CARBON FILM	100 OHM 1/6 W 5% TA26		SW608	LG 556 219B		SWITCH, TACT	THVV502GAA POSTECH DC 12 V 5	
R612	QRE141J 102Y		RESISTOR, FIXED CARBON FILM	1K OHM 1/6 W 5% TA26		SW609	LG 556 219B		SWITCH, TACT	THVV502GAA POSTECH DC 12 V 5	
R621	QRE141J 103Y		RESISTOR, FIXED CARBON FILM	10K OHM 1/6 W 5% TA26		SW610	LG 556 219B		SWITCH, TACT	THVV502GAA POSTECH DC 12 V 5	
R622	QRD161J 223Y		RESISTOR, FIXED CARBON FILM	22K OHM 1/6 W 5% TA26							
R623	QRE141J 103Y		RESISTOR, FIXED CARBON FILM	10K OHM 1/6 W 5% TA26							
R624	QRD161J 223Y		RESISTOR, FIXED CARBON FILM	22K OHM 1/6 W 5% TA26							
R631	QRE141J 103Y		RESISTOR, FIXED CARBON FILM	10K OHM 1/6 W 5% TA26							
R632	QRE141J 103Y		RESISTOR, FIXED CARBON FILM	10K OHM 1/6 W 5% TA26							
R650	QRD161J 101Y		RESISTOR, FIXED CARBON FILM	100 OHM 1/6 W 5% TA26							
R651	QRD161J 101Y		RESISTOR, FIXED CARBON FILM	100 OHM 1/6 W 5% TA26							
R652	QRD161J 750Y		RESISTOR, FIXED CARBON FILM	75 OHM 1/6 W 5% TA26							
R653	QRD161J 750Y		RESISTOR, FIXED CARBON FILM	75 OHM 1/6 W 5% TA26							
R655	QRD161J 561		RESISTOR, FIXED CARBON FILM	560 OHM 1/6 W 5% TA26							
R656	QRD161J 561		RESISTOR, FIXED CARBON FILM	560 OHM 1/6 W 5% TA26							
R657	QRD161J 561		RESISTOR, FIXED CARBON FILM	560 OHM 1/6 W 5% TA26							
R669	QRE141J 331Y		RESISTOR, FIXED CARBON FILM	330 OHM 1/6 W 5% TA26							
R670	QRE141J 331Y		RESISTOR, FIXED CARBON FILM	330 OHM 1/6 W 5% TA26							
R671	QRD161J 561		RESISTOR, FIXED CARBON FILM	560 OHM 1/6 W 5% TA26							
R678	QRE141J 331Y		RESISTOR, FIXED CARBON FILM	330 OHM 1/6 W 5% TA26							
R679	QRE141J 331Y		RESISTOR, FIXED CARBON FILM	330 OHM 1/6 W 5% TA26							
R680	QRD161J 104Y		RESISTOR, FIXED CARBON FILM	100K OHM 1/6 W 5% TA26							
R681	QRD161J 563Y		RESISTOR, FIXED CARBON FILM	56K OHM 1/6 W 5% TA26							
R682	QRD161J 153Y		RESISTOR, FIXED CARBON FILM	15K OHM 1/6 W 5% TA26							
R683	QRD161J 332Y		RESISTOR, FIXED CARBON FILM	3.3K OHM 1/6 W 5% TA26							
R684	QRE141J 103Y		RESISTOR, FIXED CARBON FILM	10K OHM 1/6 W 5% TA26							
R685	QRD161J 222Y		RESISTOR, FIXED CARBON FILM	2.2K OHM 1/6 W 5% TA26							
R686	QRD161J 561		RESISTOR, FIXED CARBON FILM	560 OHM 1/6 W 5% TA26							
R687	QRD161J 682Y		RESISTOR, FIXED CARBON FILM	6.8K OHM 1/6 W 5% TA26							
R688	QRD161J 393Y		RESISTOR, FIXED CARBON FILM	39K OHM 1/6 W 5% TA26							
R689	QRE141J 333Y		RESISTOR, FIXED CARBON FILM	33K OHM 1/6 W 5% TA26							
R690	QRD161J 562Y		RESISTOR, FIXED CARBON FILM	5.6K OHM 1/6 W 5% TA26							
RS501	LG 6500RAB003A		SENSOR	SG 260 KODENSHI D33 REEL SENSO							
T102	LG 6500RAB003A		SENSOR	SG 260 KODENSHI D33 REEL SENSO							
RS501	LG 6170RNGW12A		TRANSFORMER, SMPS[COIL]	EER3530 SOOJUNG WIDE EER3530							
W866	LG 0CN1040K948		CAPACITOR, FIXED TUBULAR(High d	0.1UF D 50V 80%, 20% F(Y5V) TA							
W867	LG 0CN1040K948		CAPACITOR, FIXED TUBULAR(High d	0.1UF D 50V 80%, 20% F(Y5V) TA							
X301	LG 6202R AJ04C		RESONATOR, CRYSTAL	HC 49U BUBANG 3.579620MHZ 15PP							
X302	LG 6202R AJ07E		RESONATOR, CRYSTAL	H49U SSANG TAE 4433783HZ 15P							
X501	LG 6202R31001E		RESONATOR, CRYSTAL	ATS SSANG TAE 10000000HZ 30PP							
ZD101	MTZJ3.3B		DIODE, ZENER	MTZJ3.3B TP ROHM K D034 0.5W 3							
ZD103	MTZ13AT 77		DIODE, ZENER	MTZ13A TP ROHM K							
ZD105	MTZJ5.6C		DIODE, ZENER	MTZ5.6C TP(26MM) ROHM 5.6V							
ZD172	LG 0DZ120009BH		DIODE, ZENERS	UZ 12BSC PYUNG CHANG TP26 D034							
ZD503	MTZJ6.8C		DIODE, ZENER	MTZ6.8C TP ROHM K							

KARAOKE KEY BOARD ASSEMBLY <32>

A42	LG 3501R 6334A	BOARD ASSEMBLY	JVC KARAOKE KEY
LED601	LG 0DL112000AJ	DIODE, LED	DL 11S2RNS/SUPER, RED, 03/KOC
LED602	LG 0DL112000AJ	DIODE, LED	DL 11S2RNS/SUPER, RED, 03/KOC
R630	QRE141J 151Y	RESISTOR, FIXED CARBON FILM	150 OHM 1/6 W 5% TA26
R631	QRE141J 151Y	RESISTOR, FIXED CARBON FILM	150 OHM 1/6 W 5% TA26
R633	QRE141J 681Y	RESISTOR, FIXED CARBON FILM	680 OHM 1/6 W 5% TA26
R634	QRD161J 821Y	RESISTOR, FIXED CARBON FILM	820 OHM 1/6 W 5% TA26
SW631	LG 556 219B	SWITCH, TACT	THVV502GAA POSTECH DC 12 V 5
SW632	LG 556 219B	SWITCH, TACT	THVV502GAA POSTECH DC 12 V 5
SW633	LG 556 219B	SWITCH, TACT	THVV502GAA POSTECH DC 12 V 5

KARAOKE JACK BOARD ASSEMBLY <33>

A41	LG 6871R 5720B	PWB(PCB) ASSEMBLY, TOTAL	KARAOKE JACK DCJK503WQ
CAM2	QET61CM 106Z	CAPACITOR, ELECTROLYTIC	10M SRA 16V M FM5 TP(5)
CAM3	LG 0CN1010K418	CAPACITOR, TUBULAR(HIGH DIELEC)	100PF 50V J B TA26
CAM5	QET61CM 106Z	CAPACITOR, ELECTROLYTIC	10M SRA 16V M FM5 TP(5)
CAM6	QET61CM 106Z	CAPACITOR, ELECTROLYTIC	10M SRA 16V M FM5 TP(5)
CAM7	QET61CM 106Z	CAPACITOR, ELECTROLYTIC	10M SRA 16V M FM5 TP(5)
IC4M1	NJM4580D	IC, PERIPHERALS	NJM4580D JRC 8 DIP ST SWITCHIN
MC401	LG 6612RFV001D	JACK, PHONE	HTJ 064 277KKG KUNMING 2INPURT
P4M01	LG 6631R E007J	CONNECTOR ASSY	8283 / 9073 5 PIN 80MM UL1061
R4J1	QRD161J 104Y	RESISTOR, FIXED CARBON FILM	100K OHM 1/6 W 5% TA26
R4J2	QRD161J 104Y	RESISTOR, FIXED CARBON FILM	100K OHM 1/6 W 5% TA26
R4J3	QRD161J 104Y	RESISTOR, FIXED CARBON FILM	100K OHM 1/6 W 5% TA26
R4J4	QRD161J 104Y	RESISTOR, FIXED CARBON FILM	100K OHM 1/6 W 5% TA26
R4M1	QRE141J 102Y	RESISTOR, FIXED CARBON FILM	1K OHM 1/6 W 5% TA26
R4M2	QRE141J 103Y	RESISTOR, FIXED CARBON FILM	10K OHM 1/6 W 5% TA26
R4M3	QRE141J 102Y	RESISTOR, FIXED CARBON FILM	1K OHM 1/6 W 5% TA26
R4M4	QRD161J 562Y	RESISTOR, FIXED CARBON FILM	5.6K OHM 1/6 W 5% TA26
R4M5	QRE141J 102Y	RESISTOR, FIXED CARBON FILM	1K OHM 1/6 W 5% TA26
R4M6	QRD161J 273Y	RESISTOR, FIXED CARBON FILM	27K OHM 1/6 W 5% TA26
R4M9	QRD161J 273Y	RESISTOR, FIXED CARBON FILM	27K OHM 1/6 W 5% TA26
ZD4J3	MTZ13AT 77	DIODE, ZENER	MTZ13A TP ROHM K
ZD4J4	MTZ13AT 77	DIODE, ZENER	MTZ13A TP ROHM K

SUB BOARD ASSEMBLY <50>

A46A	LG 6885R 0260A	SUB PWB(PCB) ASSEMBLY	495200CA120500 FF B200020AC8 (
C201	LG 0CH1104K942	CAPACITOR, CHIP[CERAMIC M/L HD	0.1UF 50V Z Y5V(F) 1508 R/TP
C202	LG 0CH1104K942	CAPACITOR, CHIP[CERAMIC M/L HD	0.1UF 50V Z Y5V(F) 1508 R/TP
C203	LG 0CH1104K942	CAPACITOR, CHIP[CERAMIC M/L HD	0.1UF 50V Z Y5V(F) 1508 R/TP

KARAOKE TIMER BOARD ASSEMBLY <31>

A49	LG 3501R 6333A	BOARD ASSEMBLY	JVC KARAOKE TIMER
C601	QET61CM 106Z	CAPACITOR, ELECTROLYTIC	10M SRA 16V M FM5 TP(5)
C602	LG 0CE4774C638	CAPACITOR, FIXED	

*NSP : Not service parts

#	REF No.	PART No.	PART NAME, DESCRIPTION	SPECIFICATION	NSP	#	REF No.	PART No.	PART NAME, DESCRIPTION	SPECIFICATION	NSP
C535		NCF31CZ 104X	CAPACITOR, FIXED CERAMIC(Temp.c	0.1UF 16V 80%, 20% Y5V(F) 1608		R204		NRS463J 102X	RESISTOR, METAL GLAZED(CHIP)	1K OHM 1 / 16 W 1608 5% D	
C536		NCF31CZ 104X	CAPACITOR, FIXED CERAMIC(Temp.c	0.1UF 16V 80%, 20% Y5V(F) 1608		R207		NRS463J 105X	RESISTOR, METAL GLAZED(CHIP)	1M OHM 1 / 16 W 1608 5% D	
C540		LG 0CH1225F944	CAPACITOR, FIXED CERAMIC(Temp.c	2.2UF 16V 80%, 20% Y5V(F) 3216		R217		NRS463J 100X	RESISTOR, METAL GLAZED(CHIP)	10 OHM 1 / 16 W 1608 5% D	
C540		NDC31HJ 220X	CAPA, CHIP CERAMIC ML T.C F/S	22P 50V J COG 1.6X0.8 R/TP		R218		NRS463J 471X	RESISTOR, METAL GLAZED(CHIP)	470 OHM 1 / 16 W 1608 5% D	
C541		NDC31HJ 270X	CAPACITOR, CHIP CERAMIC ML TC	27PF 50V J NPO 1608 R/TP		R219		NRS463J 103X	RESISTOR, METAL GLAZED(CHIP)	10K OHM 1 / 16 W 1608 5% D	
C542		NCF31CZ 104X	CAPACITOR, FIXED CERAMIC(Temp.c	0.1UF 16V 80%, 20% Y5V(F) 1608		R220		NRS463J 103X	RESISTOR, METAL GLAZED(CHIP)	10K OHM 1 / 16 W 1608 5% D	
C543		NCF31CZ 104X	CAPACITOR, FIXED CERAMIC(Temp.c	0.1UF 16V 80%, 20% Y5V(F) 1608		R230		NRS463J 101X	RESISTOR, METAL GLAZED(CHIP)	100 OHM 1 / 16 W 1608 5% D	
C544		LG 0CH1225F944	CAPACITOR, FIXED CERAMIC(Temp.c	2.2UF 16V 80%, 20% Y5V(F) 3216		R231		NRS463J 101X	RESISTOR, METAL GLAZED(CHIP)	100 OHM 1 / 16 W 1608 5% D	
C546		NDC31HJ 221X	CAPACITOR, CHIP CERAMIC ML TC	220P 50V J COG 1.6X0.8 R/TP		R232		NRS463J 101X	RESISTOR, METAL GLAZED(CHIP)	100 OHM 1 / 16 W 1608 5% D	
C549		NDC31HJ 221X	CAPACITOR, CHIP CERAMIC ML TC	220P 50V J COG 1.6X0.8 R/TP		R233		NRS463J 101X	RESISTOR, METAL GLAZED(CHIP)	100 OHM 1 / 16 W 1608 5% D	
C550		NCF31CZ 104X	CAPACITOR, FIXED CERAMIC(Temp.c	0.1UF 16V 80%, 20% Y5V(F) 1608		R234		NRS463J 101X	RESISTOR, METAL GLAZED(CHIP)	100 OHM 1 / 16 W 1608 5% D	
C553		NDC31HJ 221X	CAPACITOR, CHIP CERAMIC ML TC	220P 50V J COG 1.6X0.8 R/TP		R235		NRS463J 101X	RESISTOR, METAL GLAZED(CHIP)	100 OHM 1 / 16 W 1608 5% D	
C554		NCF31CZ 104X	CAPACITOR, FIXED CERAMIC(Temp.c	0.1UF 16V 80%, 20% Y5V(F) 1608		R236		NRS463J 101X	RESISTOR, METAL GLAZED(CHIP)	100 OHM 1 / 16 W 1608 5% D	
C555		NDC31HJ 101X	CHIP CAPA CERAMIC ML T.C F/S	100P 50V J COG 1.6X0.8 R/TP		R237		NRS463J 101X	RESISTOR, METAL GLAZED(CHIP)	100 OHM 1 / 16 W 1608 5% D	
C556		NDC31HJ 101X	CHIP CAPA CERAMIC ML T.C F/S	100P 50V J COG 1.6X0.8 R/TP		R239		NRS463J 0R0X	RESISTOR, METAL GLAZED(CHIP)	0 OHM 1 / 16 W 1608 5% D	
C557		NDC31HJ 270X	CAPACITOR, CHIP CERAMIC ML TC	27PF 50V J NPO 1608 R/TP		R240		NRS463J 0R0X	RESISTOR, METAL GLAZED(CHIP)	0 OHM 1 / 16 W 1608 5% D	
C558		NCF31CZ 104X	CAPACITOR, FIXED CERAMIC(Temp.c	0.1UF 16V 80%, 20% Y5V(F) 1608		R241		NRS463J 0R0X	RESISTOR, METAL GLAZED(CHIP)	0 OHM 1 / 16 W 1608 5% D	
C601		LG 0CE4774C638	CAPACITOR, FIXED ELECTROLYTIC	470UF SRA, SS 6.3V 20% FM5 TP 5		R242		NRS463J 0R0X	RESISTOR, METAL GLAZED(CHIP)	0 OHM 1 / 16 W 1608 5% D	
C603		QET61CM 107Z	CAPACITOR, ELECTROLYTIC	100U SRA 16V M FM5 TP(5)		R243		NRS463J 0R0X	RESISTOR, METAL GLAZED(CHIP)	0 OHM 1 / 16 W 1608 5% D	
C604		LG 0CE4774C638	CAPACITOR, FIXED ELECTROLYTIC	470UF SRA, SS 6.3V 20% FM5 TP 5		R252		NRS463J 0R0X	RESISTOR, METAL GLAZED(CHIP)	0 OHM 1 / 16 W 1608 5% D	
C606		NCF31CZ 104X	CAPACITOR, FIXED CERAMIC(Temp.c	0.1UF 16V 80%, 20% Y5V(F) 1608		R273		NRS463J 152X	RESISTOR, METAL GLAZED(CHIP)	1.5K OHM 1 / 16 W 1608 5% D	
C607		LG 0CE4774C638	CAPACITOR, FIXED ELECTROLYTIC	470UF SRA, SS 6.3V 20% FM5 TP 5		R274		NRS463J 621X	RESISTOR, METAL GLAZED(CHIP)	620 OHM 1 / 16 W 1608 5% D	
C614		QET61CM 106Z	CAPACITOR, ELECTROLYTIC	10M SRA 16V M FM5 TP(5)		R275		NRS463J 152X	RESISTOR, METAL GLAZED(CHIP)	1.5K OHM 1 / 16 W 1608 5% D	
C663		QET61CM 226	CAPACITOR, ELECTROLYTIC	22M SRA 16V M FM5 TP(5)		R276		NRS463J 911X	RESISTOR, METAL GLAZED(CHIP)	910 OHM 1 / 16 W 1608 5% D	
D2A1		DAN202K X	DIODE, SWITCHING	DAN202K TP ROHM KOREA SOT23 80		R277		NRS463J 151X	RESISTOR, METAL GLAZED(CHIP)	150 OHM 1 / 16 W 1608 5% D	
D2A2		DAN202K X	DIODE, SWITCHING	DAN202K TP ROHM KOREA SOT23 80		R278		NRS463J 0R0X	RESISTOR, METAL GLAZED(CHIP)	0 OHM 1 / 16 W 1608 5% D	
D2A3		DAN202K X	DIODE, SWITCHING	DAN202K TP ROHM KOREA SOT23 80		R279		NRS463J 0R0X	RESISTOR, METAL GLAZED(CHIP)	0 OHM 1 / 16 W 1608 5% D	
D603		DAN202K X	DIODE, SWITCHING	DAN202K TP ROHM KOREA SOT23 80		R281		NRS463J 0R0X	RESISTOR, METAL GLAZED(CHIP)	0 OHM 1 / 16 W 1608 5% D	
D604		DAN202K X	DIODE, SWITCHING	DAN202K TP ROHM KOREA SOT23 80		R290		NRS463J 0R0X	RESISTOR, METAL GLAZED(CHIP)	0 OHM 1 / 16 W 1608 5% D	
F602		LG 6200HJC901A	FILTER(CIRC), EMC	CFI06B1H1011MF SAMHWA TP 2 5K		R291		NRS463J 0R0X	RESISTOR, METAL GLAZED(CHIP)	0 OHM 1 / 16 W 1608 5% D	
F603		LG 6200HJC901A	FILTER(CIRC), EMC	CFI06B1H1011MF SAMHWA TP 2 5K		R292		NRS463J 102X	RESISTOR, METAL GLAZED(CHIP)	1K OHM 1 / 16 W 1608 5% D	
F604		LG 6200HJC901A	FILTER(CIRC), EMC	CFI06B1H1011MF SAMHWA TP 2 5K		R2A1		NRS463J 910X	RESISTOR, METAL GLAZED(CHIP)	91 OHM 1 / 16 W 1608 5% D	
F605		LG 6200HJC901A	FILTER(CIRC), EMC	CFI06B1H1011MF SAMHWA TP 2 5K		R2A2		NRS463J 0R0X	RESISTOR, METAL GLAZED(CHIP)	0 OHM 1 / 16 W 1608 5% D	
F606		LG 6200HJC901A	FILTER(CIRC), EMC	CFI06B1H1011MF SAMHWA TP 2 5K		R2A6		NRS463J 123X	RESISTOR, METAL GLAZED(CHIP)	12K OHM 1 / 16 W 1608 5% D	
F607		LG 6200HJC901A	FILTER(CIRC), EMC	CFI06B1H1011MF SAMHWA TP 2 5K		R2A9		NRS463J 563X	RESISTOR, METAL GLAZED(CHIP)	56K OHM 1 / 16 W 1608 5% D	
F608		LG 6200HJC901A	FILTER(CIRC), EMC	CFI06B1H1011MF SAMHWA TP 2 5K		R2B0		NRS463J 102X	RESISTOR, METAL GLAZED(CHIP)	1K OHM 1 / 16 W 1608 5% D	
F609		LG 6200HJC901A	FILTER(CIRC), EMC	CFI06B1H1011MF SAMHWA TP 2 5K		R2B1		NRS463J 102X	RESISTOR, METAL GLAZED(CHIP)	1K OHM 1 / 16 W 1608 5% D	
F610		LG 6200HJC901A	FILTER(CIRC), EMC	CFI06B1H1011MF SAMHWA TP 2 5K		R2B2		NRS463J 180X	RESISTOR, METAL GLAZED(CHIP)	18 OHM 1 / 16 W 1608 5% D	
IC201		LG 0ILNRHY002B	IC, LINEAR	HDC25D811B HYUNDAI 208 QFP TRA		R2B3		NRS463J 180X	RESISTOR, METAL GLAZED(CHIP)	18 OHM 1 / 16 W 1608 5% D	
IC203		LG 0IEB121616A	IC, ELITE MEMORY TECHNOLOGY	M12L16161A TT 50P TSOP ST 16M(R2B4		NRS463J 0R0X	RESISTOR, METAL GLAZED(CHIP)	0 OHM 1 / 16 W 1608 5% D	
IC206		TCW04FU X	IC, TOSHIBA	TC7W04FU		R2B5		NRS463J 102X	RESISTOR, METAL GLAZED(CHIP)	1K OHM 1 / 16 W 1608 5% D	
IC2A1		LG 0ILNRHI003A	IC, LINEAR	HD153702TF HITACHI 64 TQFP TRA		R2B6		NRS463J 180X	RESISTOR, METAL GLAZED(CHIP)	18 OHM 1 / 16 W 1608 5% D	
IC2A2		NJM3414AM X	IC, JRC	NJM3414AM TE1.3K(REEL) JRC		R2B7		NRS463J 180X	RESISTOR, METAL GLAZED(CHIP)	18 OHM 1 / 16 W 1608 5% D	
IC2A4		LG 0IK393000G	IC, KEC	KIA393F EL FLP 8 TP DUJAL COMPA		R2B8		NRS463J 0R0X	RESISTOR, METAL GLAZED(CHIP)	0 OHM 1 / 16 W 1608 5% D	
IC2M1		LG 0IFA303200A	IC, FAIRCHILD	KA3032 48QFP BK 5CH MOTOR DRIV		R2C0		NRS463J 562X	RESISTOR, METAL GLAZED(CHIP)	5.6K OHM 1 / 16 W 1608 5% D	
IC301		LG 0IXL957210C	IC, XILINX	XC9572XL 10TQ100C 100 QFP TRAY		R2C4		NRS463J 102X	RESISTOR, METAL GLAZED(CHIP)	1K OHM 1 / 16 W 1608 5% D	
IC3F1A		LG 6957R 253AK	PROGRAM	DCJK503WQ DVD PROGRAM		R2C5		NRS463J 102X	RESISTOR, METAL GLAZED(CHIP)	1K OHM 1 / 16 W 1608 5% D	
IC305		LG 0IHY578532A	IC, HYUNDAI	HY5785320CTC 7 86P TSOP BK S		R2C6		NRS463J 562X	RESISTOR, METAL GLAZED(CHIP)	5.6K OHM 1 / 16 W 1608 5% D	
IC401		LG 0IPRCP003B	IC, PERIPHERALS	CS4391 KZR CIRRUS LOGIC 20 TSS		R2C7		NRS463J 562X	RESISTOR, METAL GLAZED(CHIP)	5.6K OHM 1 / 16 W 1608 5% D	
IC402		NJM4580M X	IC, JRC	NJM4580M 8, DMP8 TP OP AMP 2K/R		R2C8		NRS463J 562X	RESISTOR, METAL GLAZED(CHIP)	5.6K OHM 1 / 16 W 1608 5% D	
IC501		LG 0INS860200A	IC, NATIONAL SEMICONDUCTOR	NDV8602 240 VQFP BK MICOM-MPEG		R2C9		NRS463J 562X	RESISTOR, METAL GLAZED(CHIP)	5.6K OHM 1 / 16 W 1608 5% D	
IC502		LG 0IMMRB001A	IC, MEMORIES	CAT93C56S TE13 CRYSTAL SEMICON		R2D0		NRS463J 562X	RESISTOR, METAL GLAZED(CHIP)	5.6K OHM 1 / 16 W 1608 5% D	
IC503		LG 0IFA742440F	IC, FAIRCHILD	MM74HC244SJ 20P SOIC TP 3 STA		R2D1		NRS463J 0R0X	RESISTOR, METAL GLAZED(CHIP)	0 OHM 1 / 16 W 1608 5% D	
IC506		LG 0IPMGRH003A	IC, POWER MANAGEMENT	BA18BC0FP E2 ROHM 3P TO252 3 R		R2D2		NRS463J 0R0X	RESISTOR, METAL GLAZED(CHIP)	0 OHM 1 / 16 W 1608 5% D	
IC601		MM1510XN X	IC, PERIPHERALS	MM1510XNRE MITSUBISHI 6, SOT 26A R		R2D3		NRS463J 562X	RESISTOR, METAL GLAZED(CHIP)	5.6K OHM 1 / 16 W 1608 5% D	
JK601		LG 6612J00012C	JACK, RCA	RCA 1302A 3G YUQIU DVD+VCR		R2D4		NRS463J 562X	RESISTOR, METAL GLAZED(CHIP)	5.6K OHM 1 / 16 W 1608 5% D	
L201		LG 6200HJC102A	FILTER(CIRC), EMC	HB 1M2012 102JT CERATECH TP		R2D5		NRS463J 682X	RESISTOR, METAL GLAZED(CHIP)	6.8K OHM 1 / 16 W 1608 5% D	
L203		LG 6200HJC102A	FILTER(CIRC), EMC	HB 1M2012 102JT CERATECH TP		R2D6		NRS463J 910X	RESISTOR, METAL GLAZED(CHIP)	91 OHM 1 / 16 W 1608 5% D	
L206		LG 6200HJC102A	FILTER(CIRC), EMC	HB 1M2012 102JT CERATECH TP		R2E6		NRS463J 101X	RESISTOR, METAL GLAZED(CHIP)	100 OHM 1 / 16 W 1608 5% D	
L207		LG 6200HJC102A	FILTER(CIRC), EMC	HB 1M2012 102JT CERATECH TP		R2E7		NRS463J 101X	RESISTOR, METAL GLAZED(CHIP)	100 OHM 1 / 16 W 1608 5% D	
L2A1		LG 6200HJC102A	FILTER(CIRC), EMC	HB 1M2012 102JT CERATECH TP		R2E8		NRS463J 0R0X	RESISTOR, METAL GLAZED(CHIP)	0 OHM 1 / 16 W 1608 5% D	
L2A2		LG 6200HJC102A	FILTER(CIRC), EMC	HB 1M2012 102JT CERATECH TP		R2F1		NRS463J 221X	RESISTOR, METAL GLAZED(CHIP)	220 OHM 1 / 16 W 1608 5% D	
L301		LG 6200HJC102A	FILTER(CIRC), EMC	HB 1M2012 102JT CERATECH TP		R2F2		NRS463J 221X	RESISTOR, METAL GLAZED(CHIP)	220 OHM 1 / 16 W 1608 5% D	
L302		LG 6200HJC102A	FILTER(CIRC), EMC	HB 1M2012 102JT CERATECH TP		R2F3		NRS463J 101X	RESISTOR, METAL GLAZED(CHIP)	100 OHM 1 / 16 W 1608 5% D	
L3F1		LG 6200HJC102A	FILTER(CIRC), EMC	HB 1M2012 102JT CERATECH TP		R2F4		NRS463J 101X	RESISTOR, METAL GLAZED(CHIP)	100 OHM 1 / 16 W 1608 5% D	
L502		LG 6200HJC102A	FILTER(CIRC), EMC	HB 1M2012 102JT CERATECH TP		R2F5		NRS463J 223X	RESISTOR, METAL GLAZED(CHIP)	22K OHM 1 / 16 W 1608 5% D	
L503		LG 6200HJC102A	FILTER(CIRC), EMC	HB 1M2012 102JT CERATECH TP		R2F6		NRS463J 562X	RESISTOR, METAL GLAZED(CHIP)	5.6K OHM 1 / 16 W 1608 5% D	
L504		LG 6200HJC102A	FILTER(CIRC), EMC	HB 1M2012 102JT CERATECH TP		R2F7		NRS463J 562X	RESISTOR, METAL GLAZED(CHIP)	5.6K OHM 1 / 16 W 1608 5% D	
L505		LG 6200HJC102A	FILTER(CIRC), EMC	HB 1M2012 102JT CERATECH TP		R2F8		NRS463J 222X	RESISTOR, METAL GLAZED(CHIP)	2.2K OHM 1 / 16 W 1608 5% D	
PDV03		LG 661 586L	CONNECTOR (CIRC), FFC/FPC	00 8370 121 000 800 ELCO 12PIN		R2F9		NRS463J 222X	RESISTOR, METAL GLAZED(CHIP)	2.2K OHM 1 / 16 W 1608 5% D	
Q2A1		2SA1037K(QR) X	TRANSISTOR	2SA1037K Q CHIP ROHM J		R2G1		NRS463J 222X	RESISTOR, METAL GLAZED(CHIP)	2.2K OHM 1 / 16 W 1608 5% D	
Q2A2		2SA1037K(QR) X	TRANSISTOR	2SA1037K Q CHIP ROHM J		R2G2		NRS463J 222X	RESISTOR, METAL GLAZED(CHIP)	2.2K OHM 1 / 16 W 1608 5% D	
Q2A5		LG 0TR388209AA	TRANSISTOR, BIPOLARS	CHIP KTC3882 SOT 23 TP KEC		R2G3		NRS463J 562X	RESISTOR, METAL GLAZED(CHIP)	5.6K OHM 1 / 16 W 1608 5% D	
Q2A6		LG 0TR388209AA	TRANSISTOR, BIPOLARS	CHIP KTC3882 SOT 23 TP KEC		R2G4		NRS463J 562X	RESISTOR, METAL GLAZED(CHIP)	5.6K OHM 1 / 16 W 1608 5% D	
Q2M1		DTC124EKA X	TRANSISTOR	DTC124EK TP ROHM KOREA SOT23 3		R2G7		NRS463J 103X	RESISTOR, METAL GLAZED(CHIP)	10K OHM 1 / 16 W 1608 5% D	
Q605		LG 0TR103009AC	TRANSISTOR	KRA103S T1(PC)22 22 CHIP KEC		R2G9		NRS463J 151X	RESISTOR, METAL GLAZED(CHIP)	150 OHM 1 / 16 W 1608 5% D	
Q606		LG 0TR103009AC	TRANSISTOR	KRA103S T1(PC)22 22 CHIP KEC		R2M1</					

OVERALL WIRING DIAGRAM

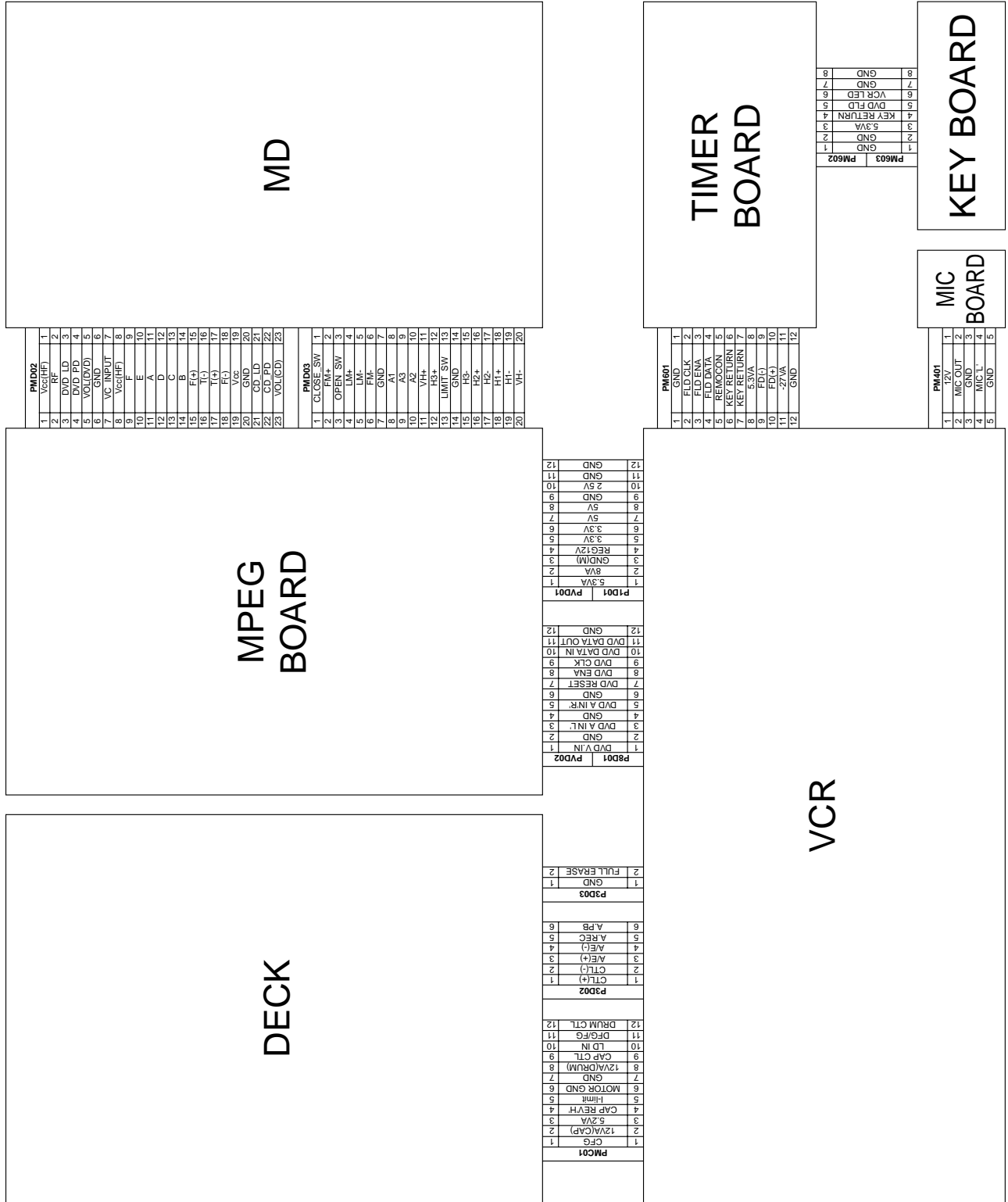

2. KARAOKE BLOCK DIAGRAM

(MIC MODE)

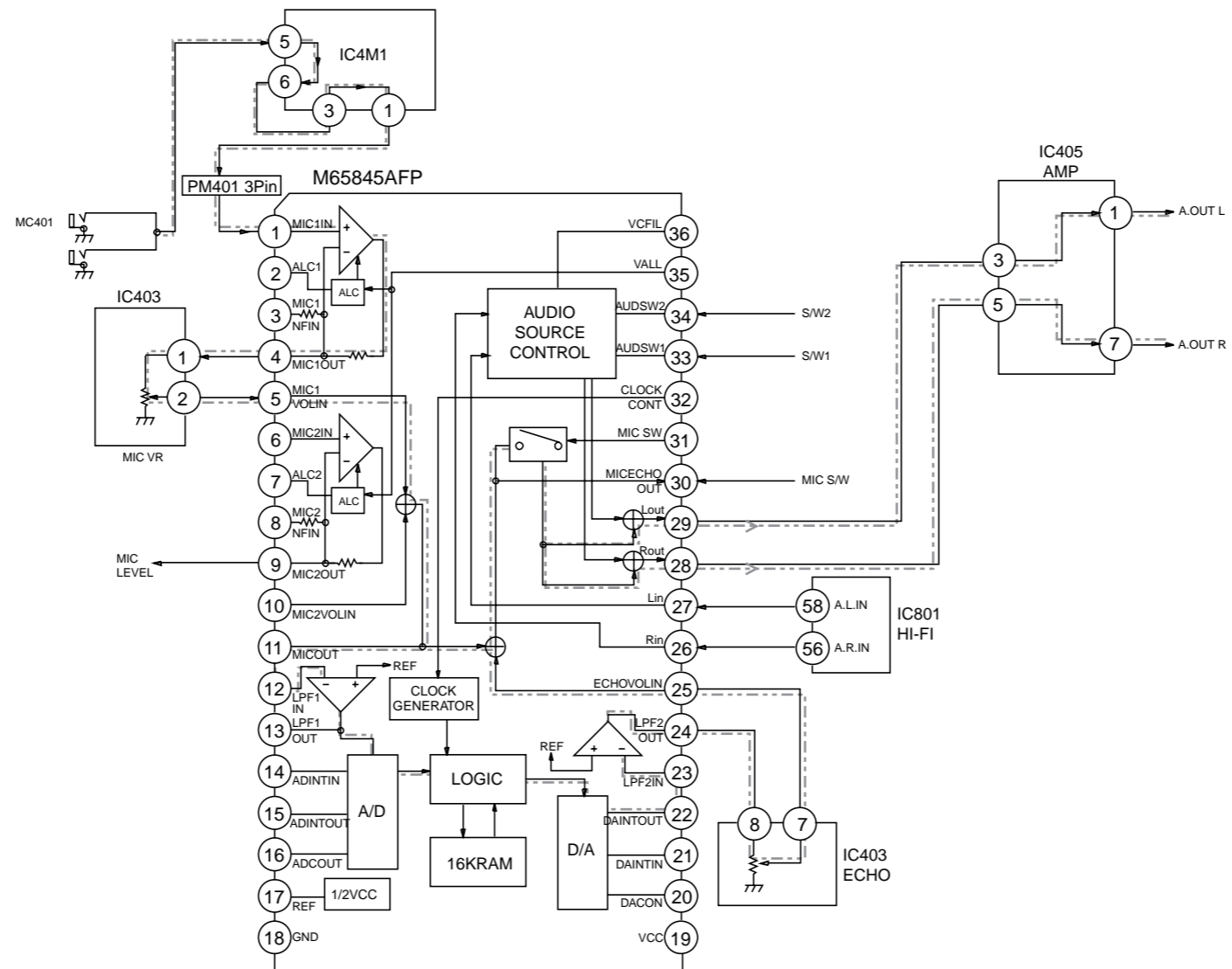

3. Y/C BLOCK DIAGRAM

(PB Mode)

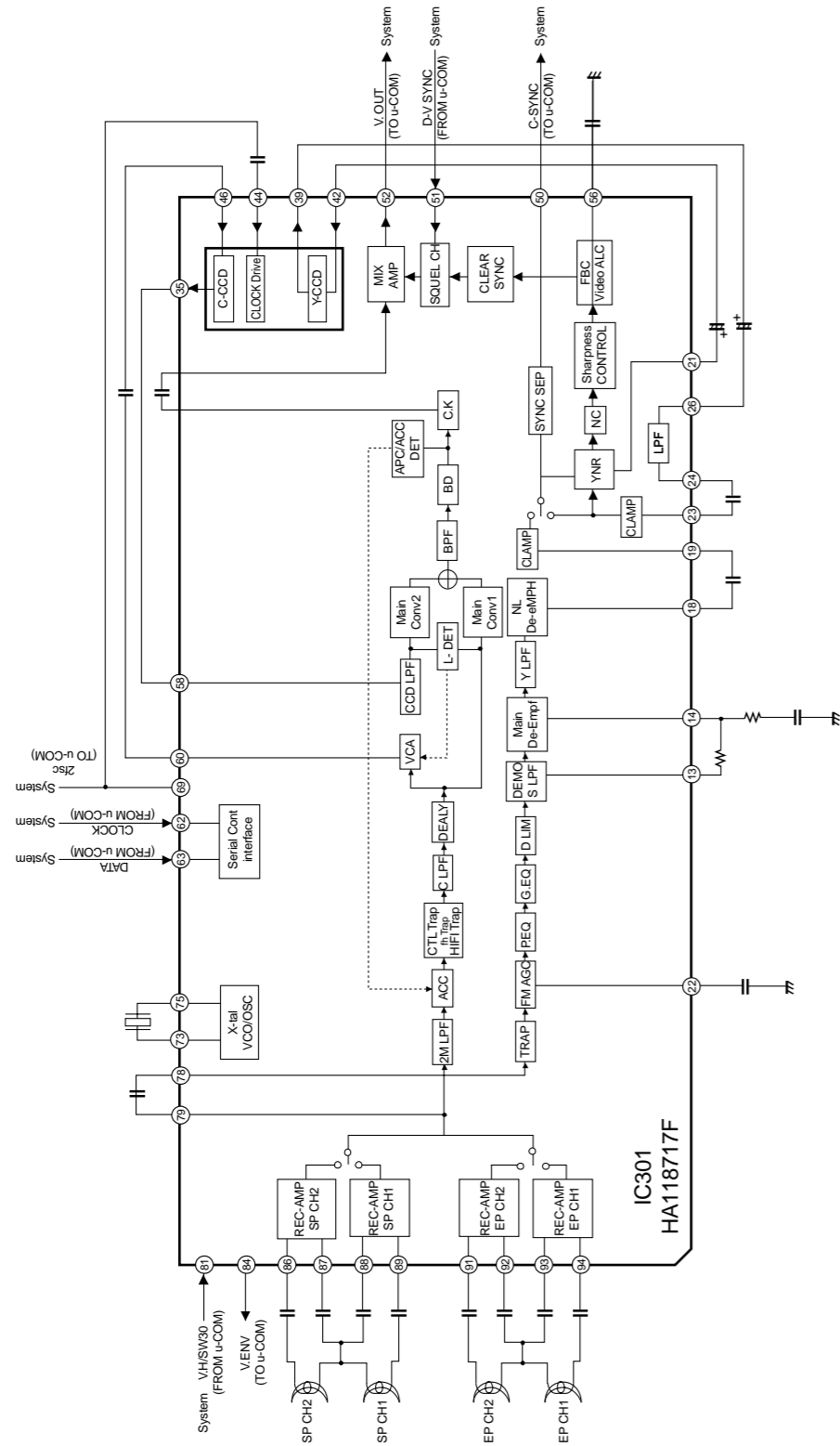

(REC Mode)

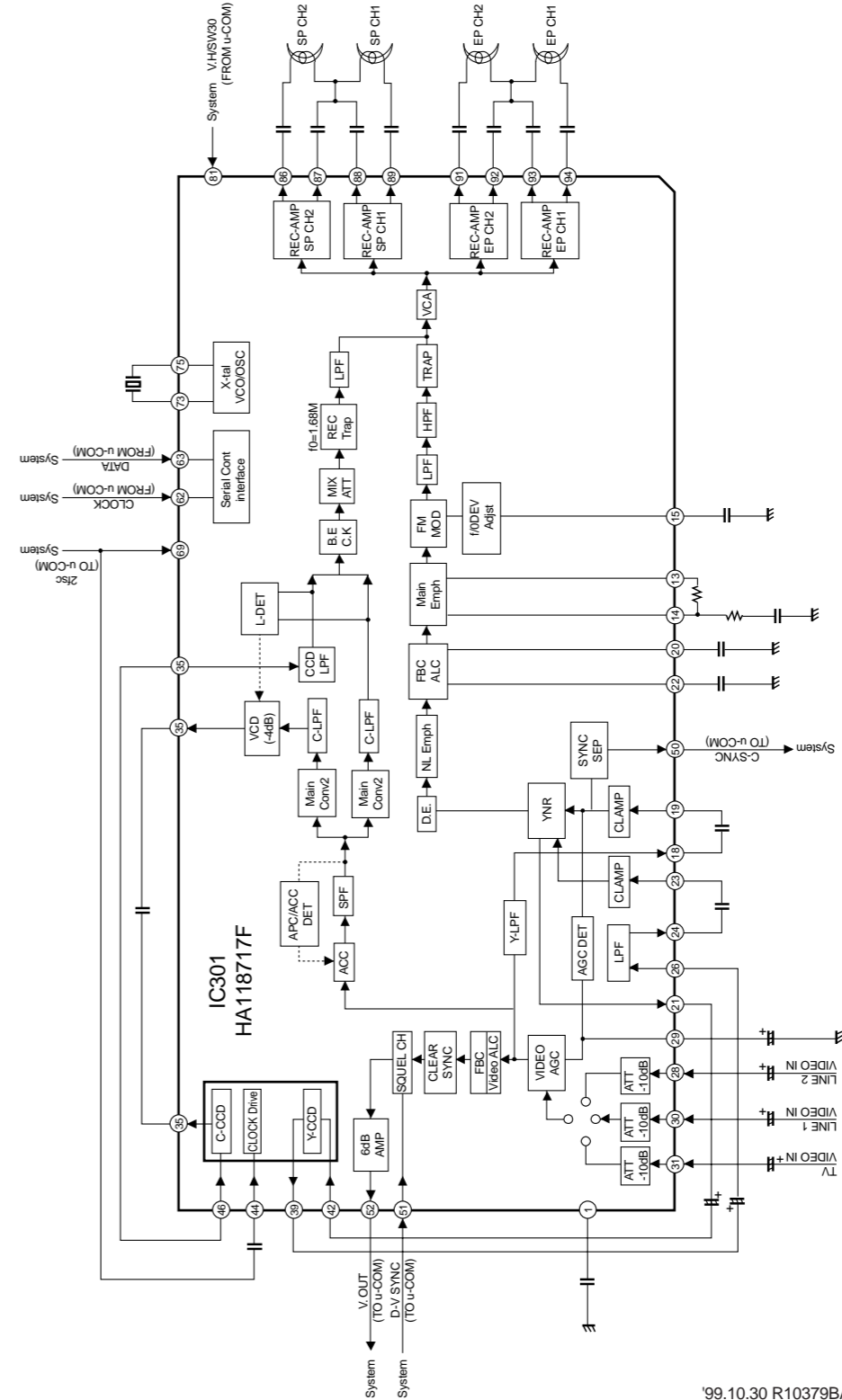

'99.10.30 R10379BA

4. NORMAL AUDIO BLOCK DIAGRAM

(PB Mode)

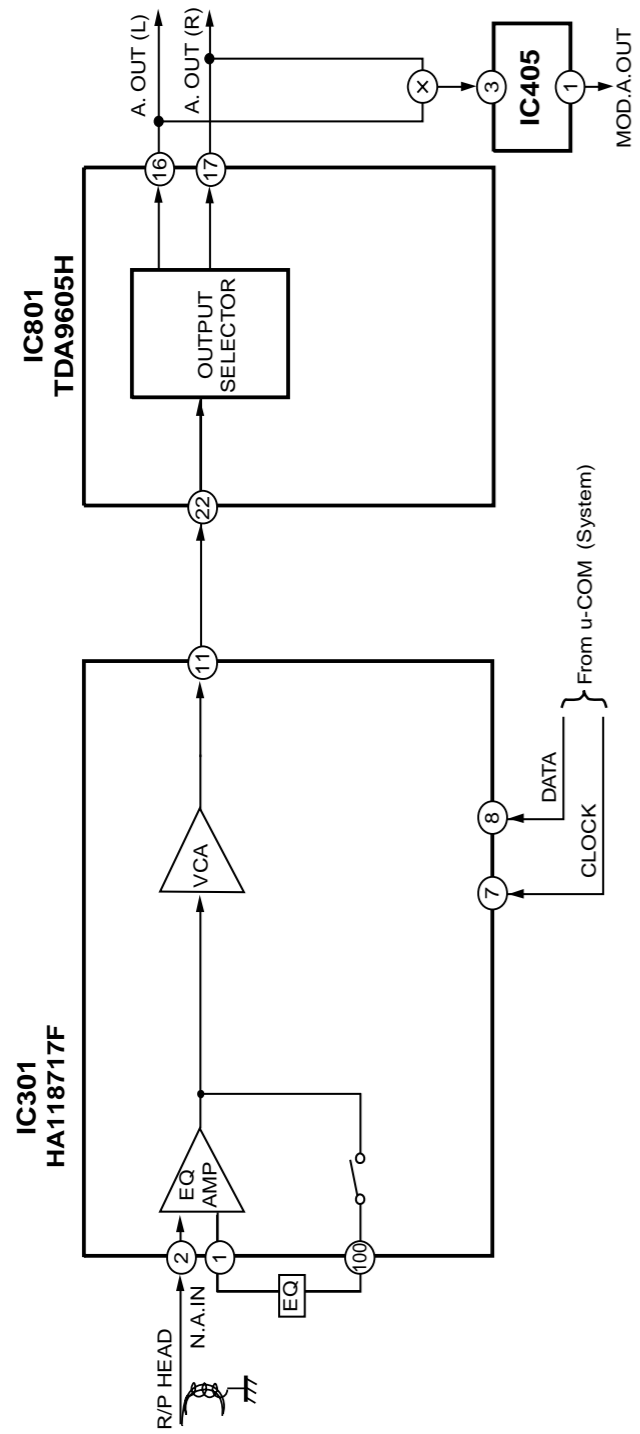

(REC Mode)

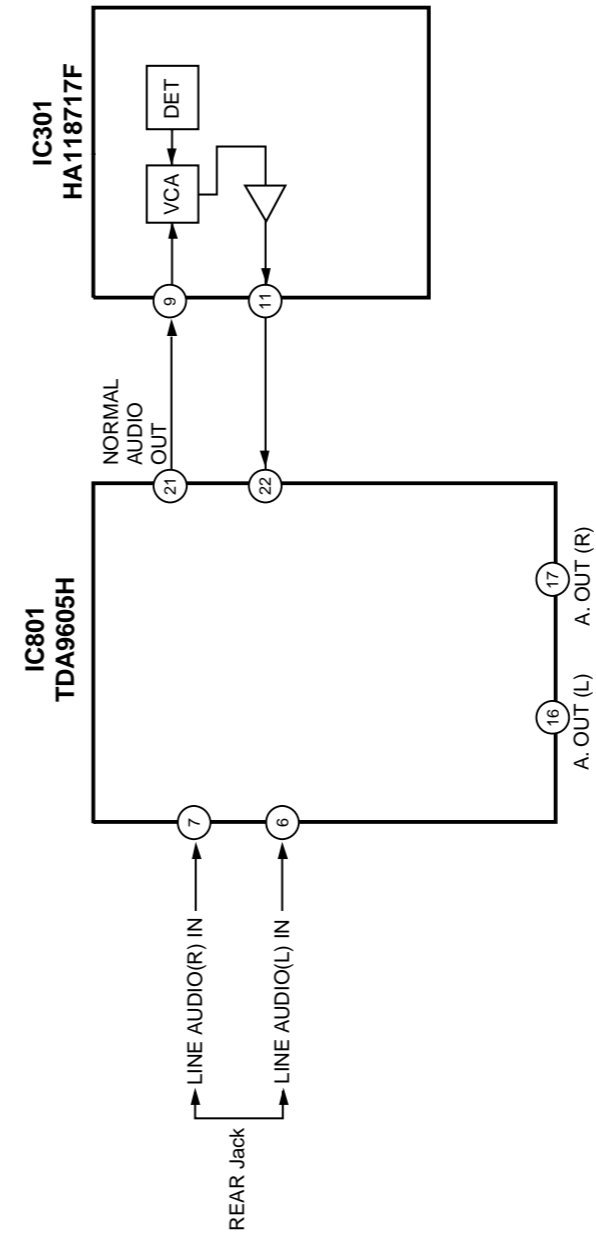

5. Hi-Fi BLOCK DIAGRAM

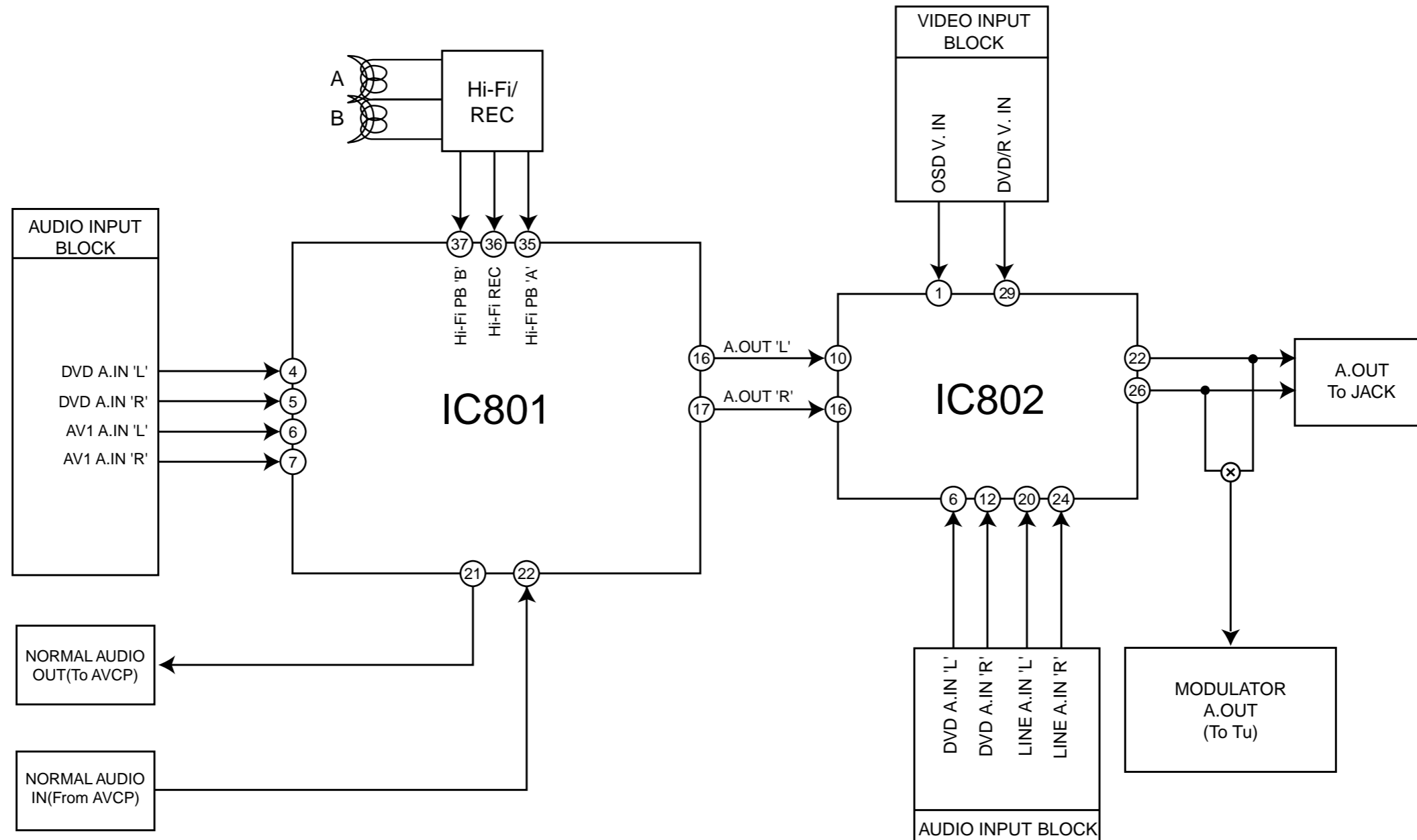

6. SYSTEM BLOCK DIAGRAM

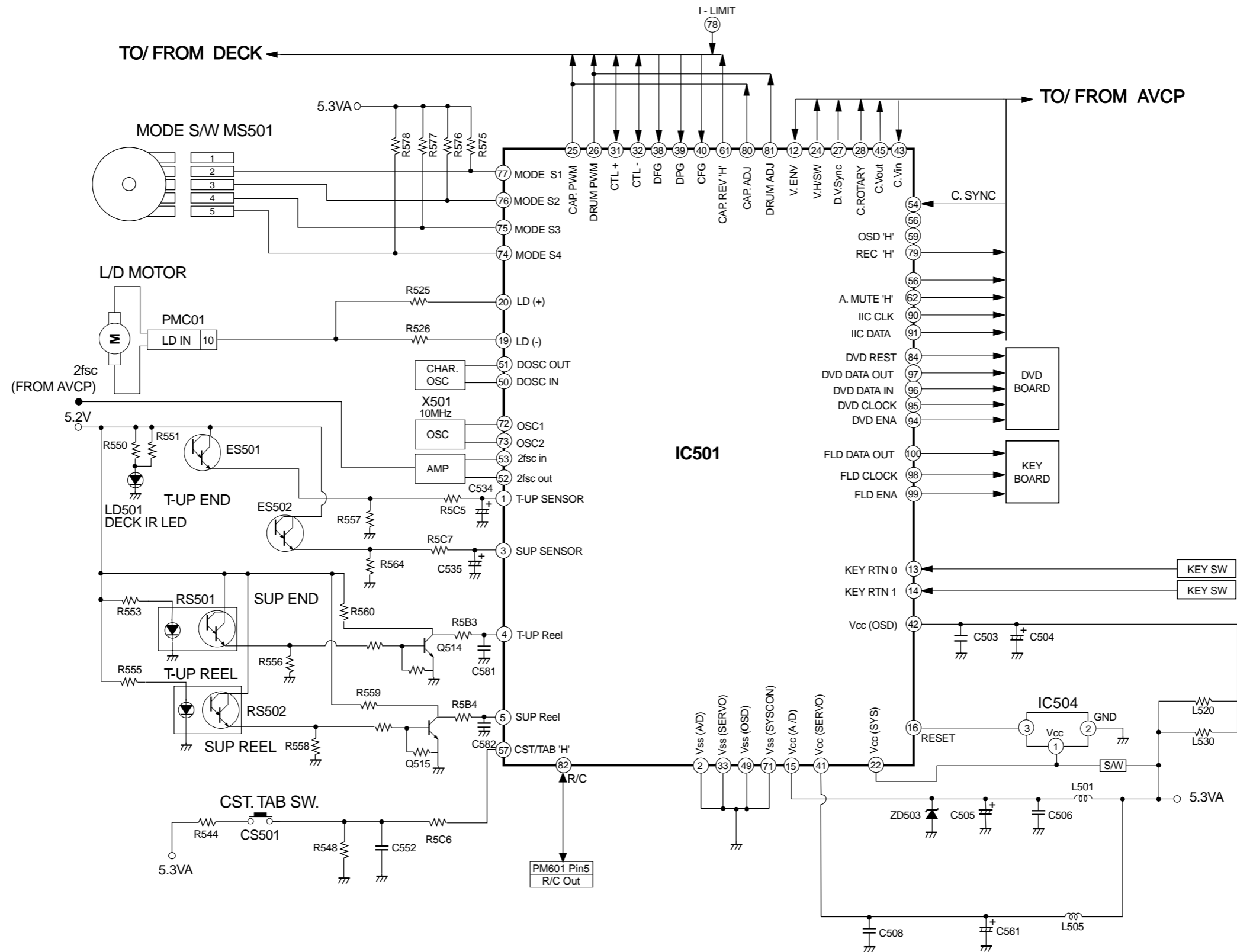

2. KARAOKE CIRCUIT DIAGRAM

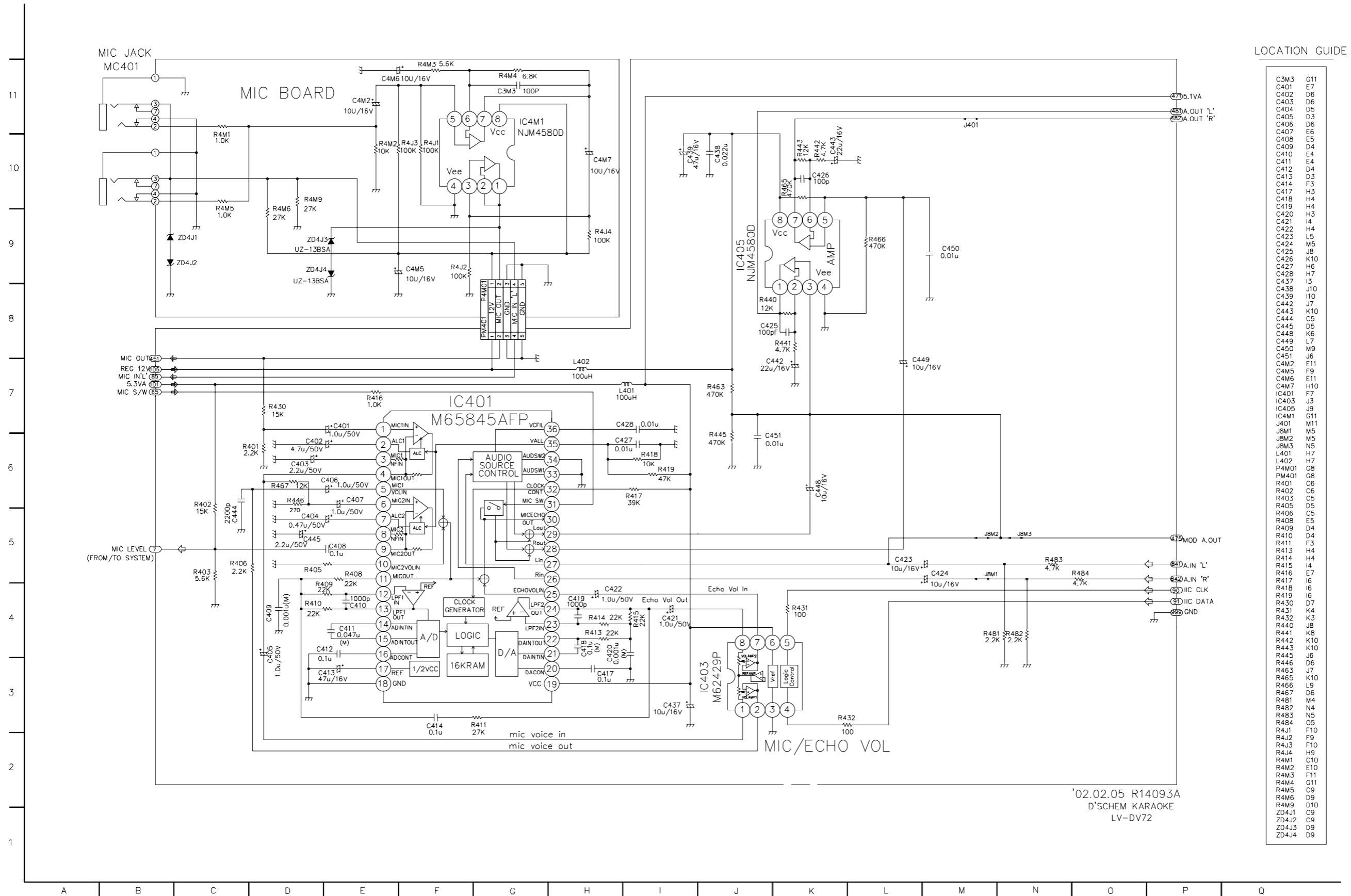

LOCATION GUIDE

C3M3	G11
C401	E7
C402	D6
C403	D6
C404	D5
C405	D3
C406	D6
C407	E6
C408	E5
C409	D4
C410	E4
C411	E4
C412	D4
C413	D3
C414	F3
C417	H3
C418	H4
C419	H4
C420	H3
C421	I4
C422	H4
C423	L5
C424	M5
C425	J8
C426	K10
C427	H6
C428	H7
C437	I3
C438	J10
C439	I10
C442	J7
C443	K10
C444	C5
C445	D5
C448	K6
C449	L7
C450	M9
C451	J6
C4M2	E11
C4M5	F9
C4M6	E11
C4M7	H10
IC401	F7
IC403	J3
IC405	J9
IC4M1	G11
J401	M11
J8M1	M5
J8M2	M5
J8M3	N5
L401	H7
L402	H7
PM401	G8
R401	C6
R402	C6
R403	C5
R405	D5
R406	C5
R408	E5
R409	D4
R410	D4
R411	F3
R413	H4
R414	H4
R415	I4
R416	E7
R417	I6
R418	I6
R419	I6
R430	D7
R431	K4
R432	K3
R440	J8
R441	K8
R442	K10
R443	K10
R445	J6
R446	D6
R453	J7
R465	K10
R466	L9
R467	D6
R481	M4
R482	N4
R483	N5
R484	O5
R4J1	F10
R4J2	F9
R4J3	F10
R4J4	H9
R4M1	C10
R4M2	E10
R4M3	F11
R4M4	G11
R4M5	C9
R4M6	D9
R4M9	D10
ZD4J1	C9
ZD4J2	C9
ZD4J3	D9
ZD4J4	D9

'02.02.05 R14093A
D'SCHEM KARAOKE
LV-DV72

3. AV CIRCUIT DIAGRAM

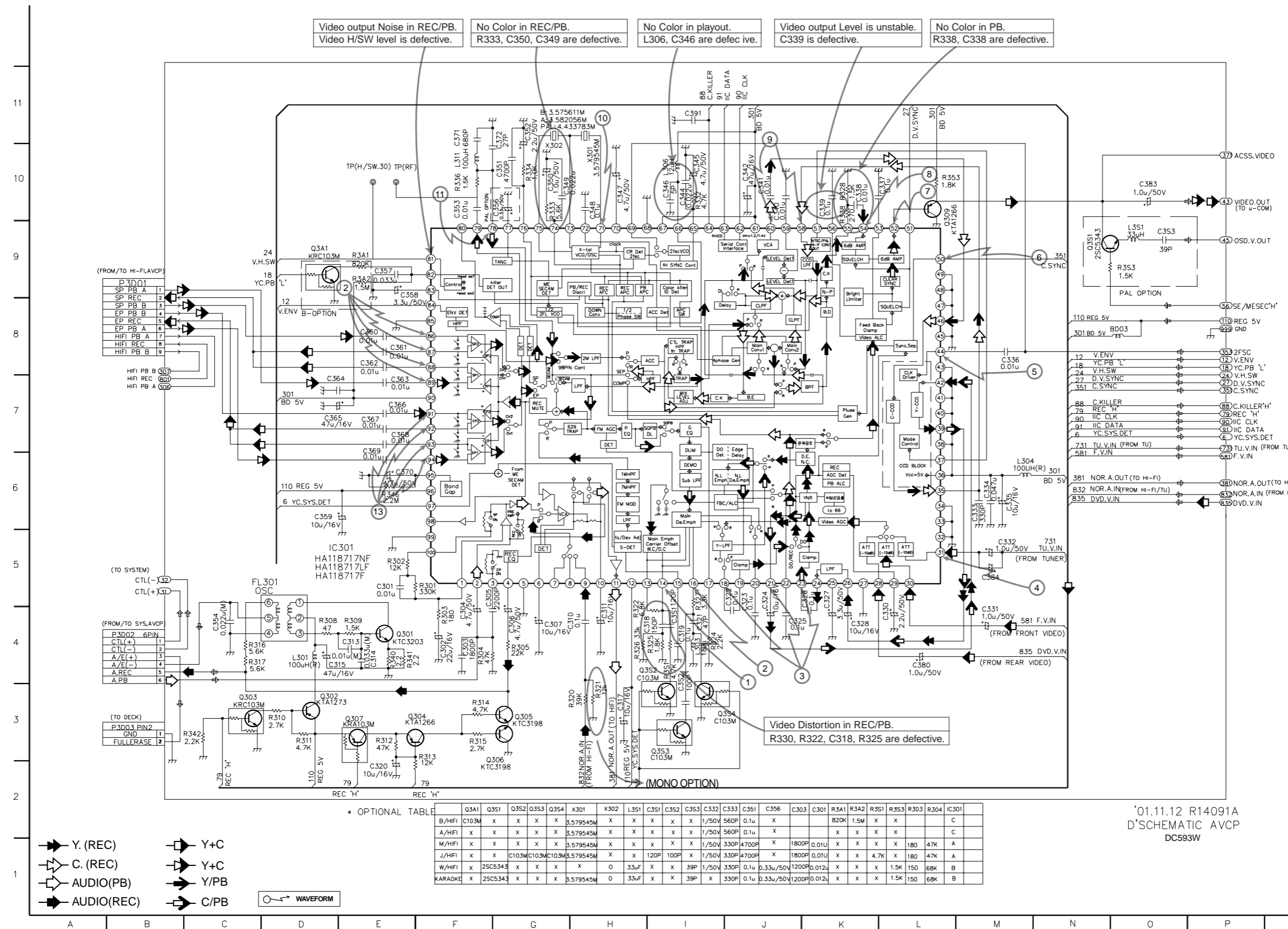

LOCATION GUIDE

B003	O8	C384	M5
C301	E5	C391	I11
C302	F4	C351	I4
C303	F4	C352	I3
C304	F4	C353	O9
C305	F5	FL301	C5
C306	G4	IC301	D5
C307	G4	L301	D4
C310	H4	L303	I4
C311	H4	L304	M6
C313	F4	L306	I10
C314	E4	L311	F10
C315	D4	L351	O9
C317	H3	P3001	B9
C318	I4	P3002	B4
C319	I4	P3003	B3
C320	E2	Q301	E4
C321	I4	Q302	D3
C322	J5	Q303	C3
C323	J4	Q304	E3
C324	J4	Q305	G3
C325	J4	Q306	F2
C326	K4	Q307	E3
C327	K4	Q309	L9
C328	K4	Q3A1	D9
C330	L4	Q351	N9
C331	M4	Q352	H4
C332	M5	Q353	I3
C333	M6	Q354	I5
C334	M6	R301	F5
C335	M6	R302	E5
C336	M8	R303	F4
C337	L10	R304	F4
C338	K10	R305	G4
C339	K10	R308	D4
C340	J10	R309	E4
C341	J10	R310	D3
C342	J10	R311	D3
C344	I10	R312	E3
C345	I10	R313	F3
C346	I10	R314	F3
C347	H10	R315	F3
C348	H10	R316	C4
C349	H10	R317	C4
C350	G10	R320	H3
C351	G10	R321	H5
C352	G11	R322	H4
C353	F10	R324	I4
C354	F10	R325	I4
C356	G10	R326	H4
C357	E9	R327	I4
C358	E9	R328	K10
C359	D6	R332	I10
C360	E8	R333	G10
C361	E8	R334	G10
C362	E8	R336	F10
C363	E7	R338	K9
C364	D7	R340	E4
C365	D7	R341	E4
C366	E7	R342	C3
C367	E7	R346	E6
C368	E7	R353	L10
C369	E6	R3A1	E9
C370	E6	R3A2	E9
C371	F10	R351	I4
C372	G10	R353	O9
C380	L4	X301	H10
C383	O10	X302	G10

* OPTIONAL TABLE

	Q3A1	Q3S1	Q3S2	Q3S3	Q3S4	X301	X302	L3S1	C3S1	C3S2	C3S3	C332	C333	C351	C356	C303	C301	R3A1	R3A2	R3S1	R3S3	R303	R304	IC301
B/HIFI	C103M	X	X	X	X	3.579545M	X	X	X	X	X	1/50V	560P	0.1u	X			B20K	1.5M	X	X			C
A/HIFI	X	X	X	X	X	3.579545M	X	X	X	X	X	1/50V	560P	0.1u	X					X	X	X		C
M/HIFI	X	X	X	X	X	3.579545M	X	X	X	X	X	1/50V	330P	4700P	X	1800P	0.01u	X	X	X	X	180	47K	A
J/HIFI	X	X	C103M	C103M	C103M	3.579545M	X	X	120P	100P	X	1/50V	330P	4700P	X	1800P	0.01u	X	X	4.7K	X	180	47K	A
W/HIFI	X	25C5343	X	X	X	X	0	33uF	X	X	39P	1/50V	330P	0.1u	0.33u/50V	1200P	0.012u	X	X	X	1.5K	150	68K	B
KARAOKE	X	25C5343	X	X	X	3.579545M	0	33uF	X	X	39P	X	330P	0.1u	0.33u/50V	1200P	0.012u	X	X	X	1.5K	150	68K	B

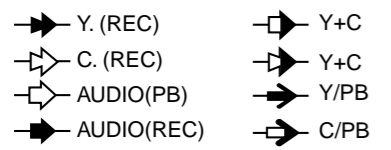

'01.11.12 R14091A
D'SCHEMATIC AVCP
DC593W

4. HI-FI CIRCUIT DIAGRAM

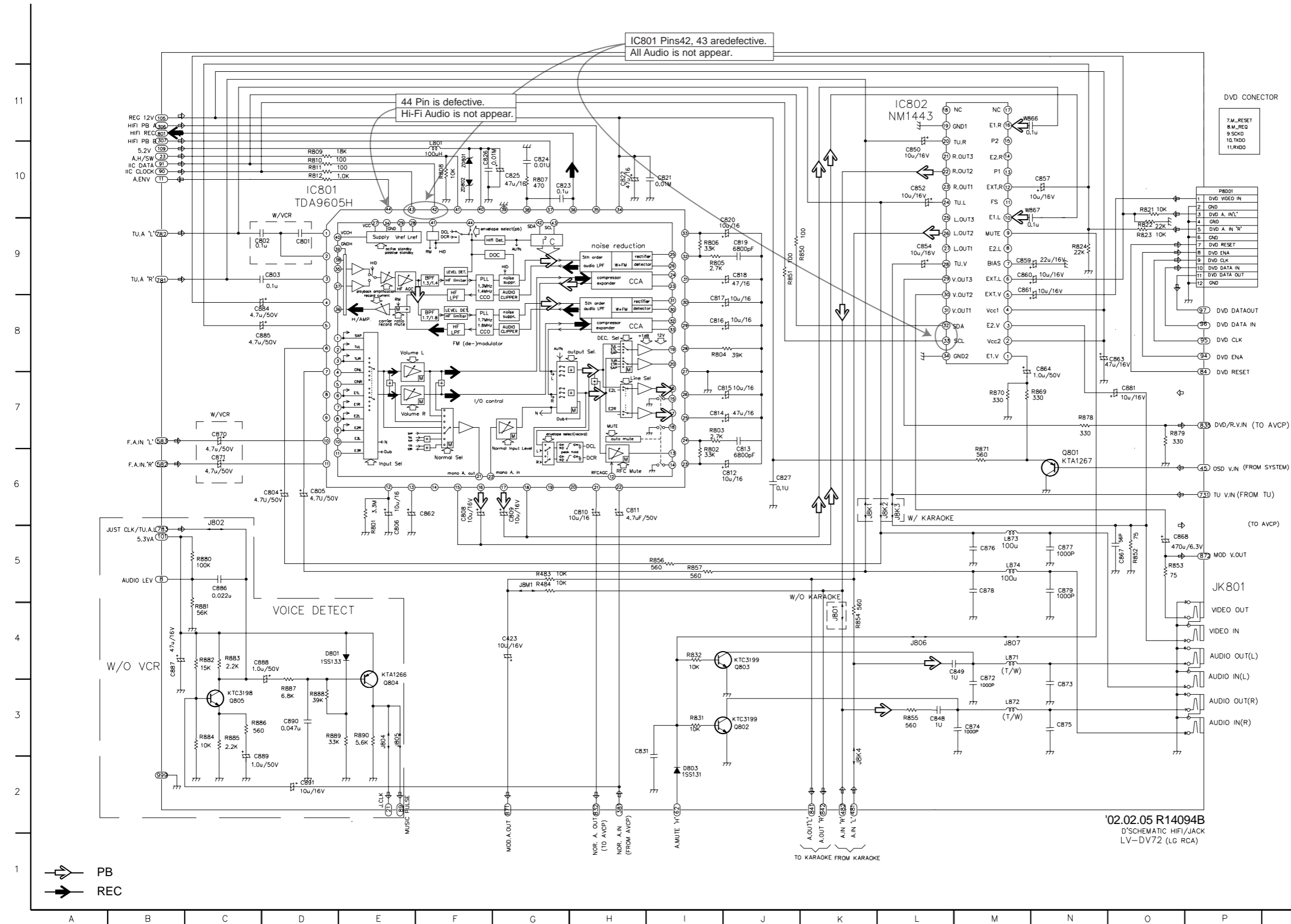

LOCATION GUIDE

C423	G4	L874	M5
C801	D9	P8001	P10
C802	C9	Q801	N6
C803	C9	Q802	J3
C804	C6	Q803	J4
C805	D6	Q804	E3
C806	E5	Q805	C3
C808	F6	R483	G5
C809	G6	R484	G5
C810	G6	R801	E5
C811	H6	R802	I6
C812	I6	R803	I7
C813	J6	R804	I8
C814	I7	R805	I9
C815	I7	R806	I9
C816	I8	R807	G10
C817	I8	R808	F10
C818	J9	R809	D10
C819	J9	R810	D10
C820	I9	R811	D10
C821	I10	R812	D10
C822	H10	R821	O10
C823	G10	R822	O9
C824	G10	R823	O9
C825	G10	R824	N9
C826	F10	R831	I3
C827	J6	R832	I4
C831	H3	R850	J9
C848	L3	R851	J9
C849	L4	R852	O5
C850	L10	R853	O5
C852	L10	R854	K4
C854	L9	R855	L3
C857	M10	R856	H5
C859	M9	R857	I5
C860	M9	R869	M7
C861	M9	R870	M7
C862	E6	R871	M6
C863	N8	R878	N7
C864	M8	R879	O7
C867	O5	R880	C5
C868	O5	R881	C4
C870	C7	R882	C4
C871	C6	R883	C4
C872	M3	R884	C3
C873	N3	R885	C3
C874	M3	R886	C3
C875	N3	R887	D3
C876	M5	R888	D3
C877	N5	R889	D3
C878	M5	R890	E3
C879	N5	W866	M11
C881	O7	W867	M10
C884	C8	Z801	F10
C885	C8	Z802	F10
C886	C5		
C887	E4		
C888	C4		
C889	C2		
C890	D3		
C891	D2		
D801	D4		
D803	I2		
IC801	D10		
IC802	L11		
J801	K4		
J802	C6		
J804	E3		
J805	E3		
J806	L4		
J807	M4		
J8K1	K6		
J8K2	L6		
J8K3	L6		
J8K4	K2		
J8M1	G5		
JK801	P5		
L801	F10		
L871	M4		
L872	M3		
L873	M5		

02.02.05 R14094B
D'SCHEMATIC HI-FI/JACK
LV-DV72 (LG RCA)

5. SYSTEM CIRCUIT DIAGRAM

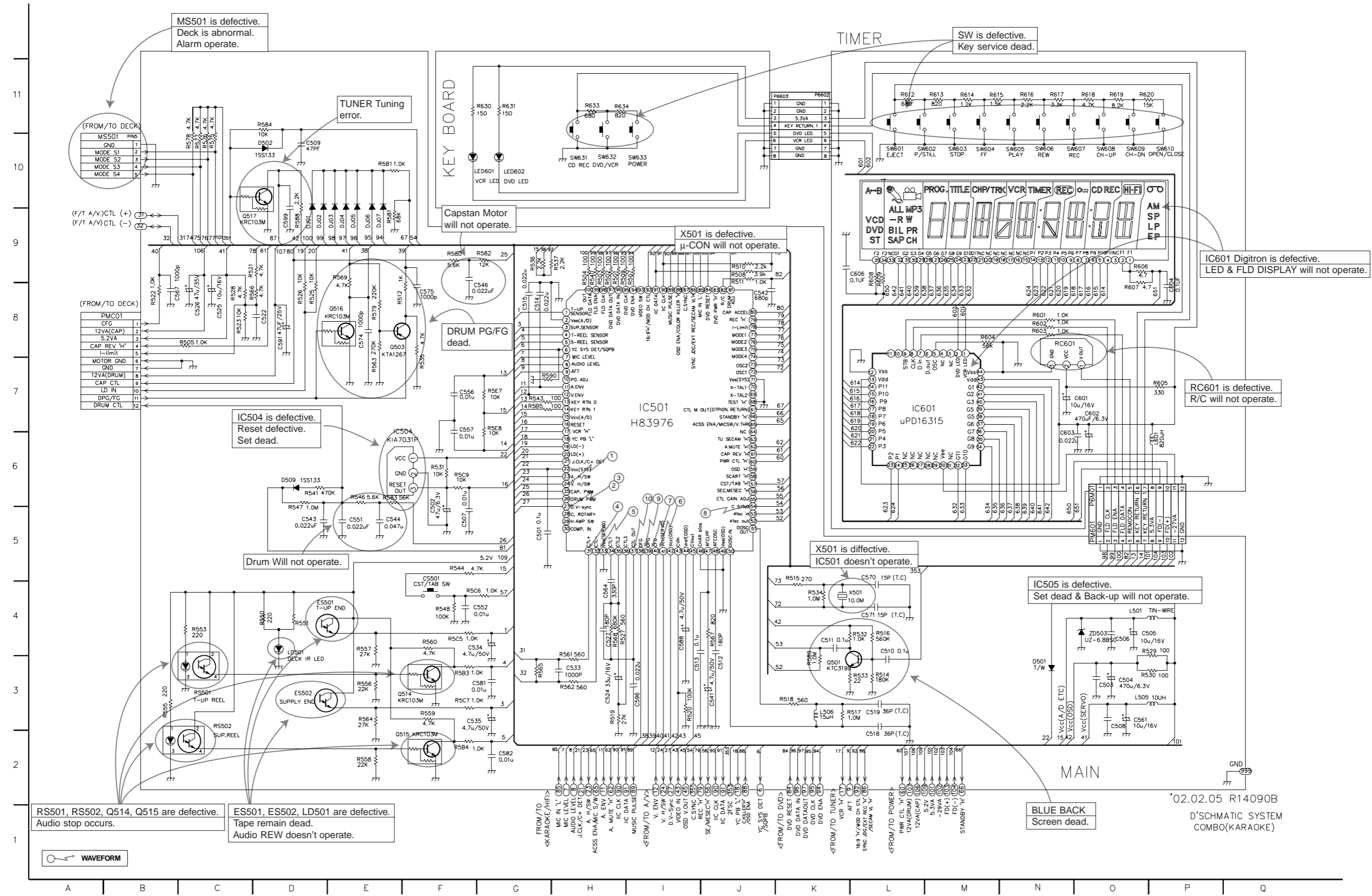

• WAVEFORMS

* IC301 Oscilloscope Waveform

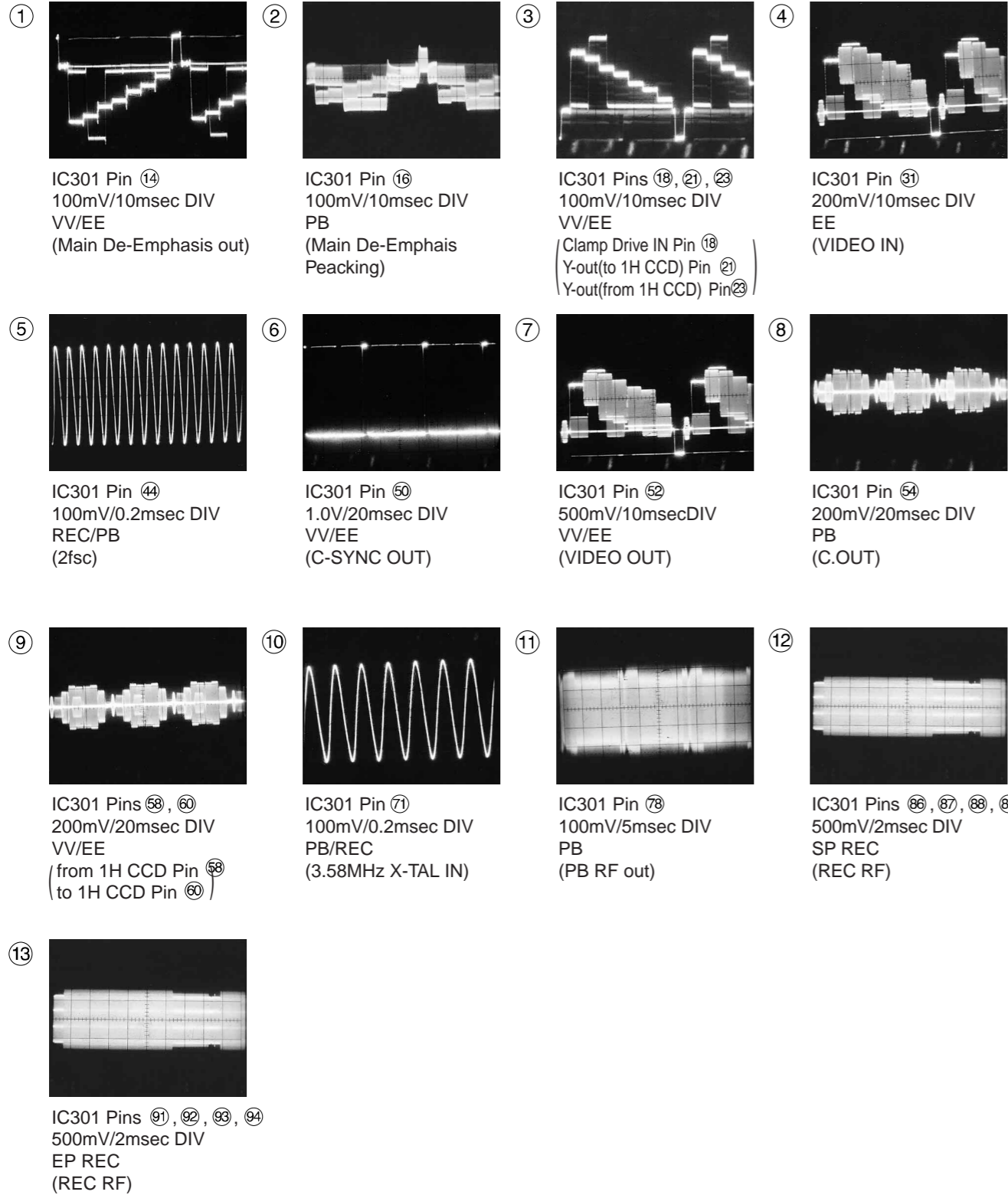

* IC501 Oscilloscope Waveform

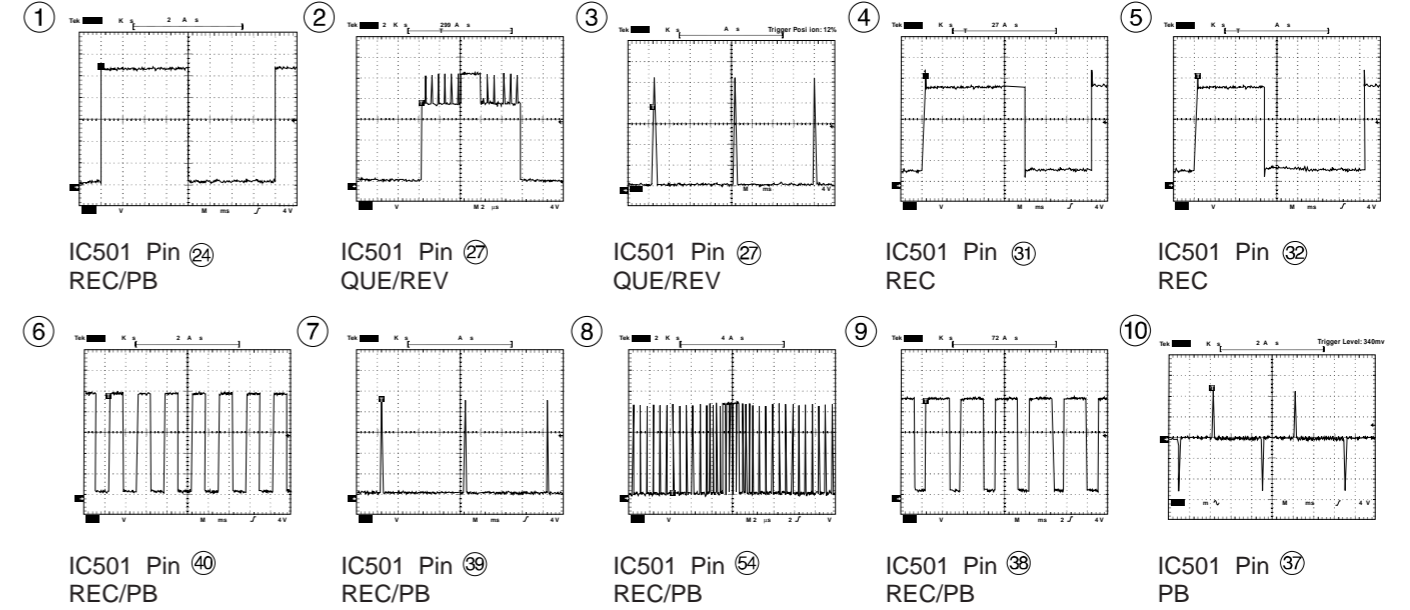

• CIRCUIT VOLTAGE CHART

MODE PIN NO.	EE	PLAY
IC 401		
1	2.6	2.6
2	2.6	2.6
3	2.6	2.6
4	2.6	2.6
5	2.6	2.6
6	2.6	2.6
7	2.6	2.6
8	2.6	2.6
9	2.6	2.6
10	2.6	2.6
11	2.6	2.6
12	2.6	2.6
13	2.6	2.6
14	2.6	2.6
15	2.6	2.6
16	0.5	0.5
17	2.6	2.6
18	0	0
19	5	5
20	0.2	0.2
21	2.6	2.6
22	2.6	2.6
23	2.6	2.6
24	2.6	2.6
25	2.6	2.6
26	2.6	2.6
27	2.6	2.6
28	6	6
29	2.6	2.6
30	-	-
31	0	0
32	1	1
33	0	0
34	0	0
35	0.9	0.9
36	2.6	2.6
IC 403		
1	2.3	2.3
2	2.4	2.3
3	0	0
4	0.5	0.5
5	0.5	0.5
6	5	5
7	2.4	2.4
8	2.3	2.3
IC 405		
1	6.1	6.1
2	6.1	6.1
3	6	6
4	0	0
5	6	6
6	6.1	6.1
7	6.1	6.1
8	12.2	12.2

MODE PIN NO.	EE	PLAY
IC 4M1		
1	6.1	6.1
2	6.1	6.1
3	0.6	0.6
4	0	0
5	6	6
6	6.1	6.1
7	6.1	6.1
8	12.2	12.2
IC 801		
1	3.8	3.8
2	3.8	3.8
3	3.8	3.8
4	3.8	3.8
5	3.8	3.8
6	3.8	3.8
7	3.8	3.8
8	3.8	3.8
9	3.8	3.8
10	3.8	3.8
11	3.8	3.8
12	0	0
13	3.8	3.8
14	0	0
15	2	2.1
16	6.1	6.1
17	6.1	6.1
18	2	2.1
19	6.1	6.1
20	6.1	6.1
21	4.6	4.6
22	3.8	3.8
23	3.8	3.9
24	3.8	3.9
25	3.9	3.9
26	0.8	0.9
27	0	0
28	3.8	3.8
29	3.9	3.9
30	0.8	0.9
31	3.9	3.9
32	3.8	3.9
33	3.8	3.9
34	12.3	12.2
35	0.3	0.3
36	0	0.7
37	0	1.2
38	0	0.7
39	0	0
40	5.1	4
41	0~2	0~2
42	0~5	0~5
43	0~5	0~5
44	0	0.6

MODE PIN NO.	EE	PLAY
IC 802		
1	3.16	3.1
2	12.2	12.3
3	2.8	2.8
4	12.2	12.3
5	4.5	3.6
6	6.3	5.8
7	5.8	5.8
8	5.7	5.8
9	0	0
10	2	2
11	0	0
12	5.8	5.8
13	0	0
14	5.8	5.8
15	0	0
16	2	2
17	-	-
18	-	-
19	0	0
20	5.8	5.8
21	5.8	5.8
22	2	2
23	5.8	5.8
24	5.8	5.8
25	5.8	5.8
26	2	2
27	5.8	5.8
28	3.7	3
29	1.9	2
30	2.3	2
31	1.4	1.4
32	5	5
33	5	5
34	0	0
IC 101		
1	5.56	5.56
2	1.7	1.82
3	0	0
4	~	~
5	~	~
6	-	-
7	15.75	16.16
8	0	0
IC 102		
1	2.48	2.48
2	0	0
3	3.91	3.96
IC 103		
1	3.81	3.91
2	3.3	3.3
3	0	0
4	4.34	4.39
IC 104		
1	3.82	3.91

MODE PIN NO.	EE	PLAY
2	3.32	3.33
3	0	0
4	4.34	4.33
IC 105		
1	4.97	5.02
2	3.91	3.96
3	0	0
4	1.68	1.82
IC 106		
1	12.25	12.5
2	7.88	7.98
3	0	0
4	4.34	4.33
IC 501		
1	0	0
2	0	0
3	0	0
4	0	0
5	0	5.1
6	0	0.5
7	0.38	0.3
8	0.37	0.3
9	2.55	4.6
10	0	0.4
11	0	0
12	1.4	0
13	5.2	5.2
14	5.2	5.2
15	5.2	5.2
16	5.18	5.2
17	0	0
18	0	0
19	0	0
20	5.14	5.1
21	0	0
22	5.19	5.2
23	2.6	2.6
24	2.6	2.6
25	2.6	2.7
26	2.6	2.6
27	0	0
28	2.6	2.6
29	5.18	0
30	0	0.6
31	2.2	3
32	2.2	0
33	0	0
34	0	0
35	2.2	0
36	2.2	2.2
37	2.2	2.2
38	2.5	2.5
39	0	0.4
40	2.4	2.5
41	5.2	5.2

MODE PIN NO.	EE	PLAY
42	4.82	4.8
43	2.2	1.4
44	1.3	1.3
45	2.2	2.1
46	0	0
47	2.5	2.6
48	0	0
49	0	0
50	0	1.2
51	1	1.1
52	2.3	2.5
53	2.4	2.4
54	0.9	0.5
55	0	0
56	0	0
57	0	0
58	0	0
59	0	0
60	5	4.7
61	0	0
62	0	4.9
63	0	0
64	0	0
65	0	0
66	0	0
67	0	0
68	0	0
69	1.4	1.4
70	0.9	0.8
71	0	0
72	2.3	2.3
73	2.4	2.4
74	5.2	5.2
75	5.2	5.2
76	5.2	5.2
77	0	0
78	3.5	3.5
79	0	4.7
80	2.7	0
81	0	2.5
82	4.4	4.6
83	0	0
84	0	4.4
85	2.5	2.4
86	5	5
87	0.7	2.7
88	0	4.3
89	3	3
90	4.7	5.2
91	4.5	5.2
92	0	4.8
93	0	0.7
94	4.2	0
95	4.6	4.6
96	0.3	3.4

MODE PIN NO.	EE	PLAY
97	0.2	4.6
98	5	5
99	4.8	5
100	0	0
IC 301		
1	2.4	2.5
2	2.4	2.5
3	0	0
4	2.3	0
5	0	0
6	2.8	2.8
7	2.5	2.8
8	2.5	2.5
9	2.5	2.5
10	2.4	2.4
11	2.4	2.4
12	5.1	5.1
13	1.4	2.1
14	1.4	2.1
15	3	2.1
16	0.7	1.7
17	2	0
18	2.1	2.3
19	3	2.9
20	2.6	1.4
21	2.2	2.2
22	2	1.9
23	3	2.8
24	2.1	2.1
25	1.4	1.4
26	2	2
27	0	0
28	2.7	2.8
29	1.9	2.1
30	2.8	2.8
31	2.7	2.8
32	0	0
33	0	0
34	0	0
35	3.1	3
36	5.1	5.1
37	0	5.1
38	5.1	5.1
39	3.3	3.2
40	5.1	5.1
41	5.1	5.1
42	2.2	2.1
43	5.1	5.1
44	2.6	2.6
45	0	0
46	2.1	2
47	0	0
48	0	0
49	0	0
50	0	0.5

MODE PIN NO.	EE	PLAY
51	0	0
52	2.3	1.4
53	2.8	2.3
54	1.9	2
55	2	2
56	2.7	2.2
57	0	5.1
58	3.1	3.1
59	2.8	2.9
60	2.1	2.5
61	5.1	5.1
62	4.9	5.2
63	4.8	5.2
64	4.3	4.3
65	3.1	3.8
66	5.1	5.1
67	5.1	5.1
68	0	0
69	2.8	2.8
70	2.5	2.5
71	2.1	2.1
72	1.3	2.2
73	1.6	1.7
74	1	2.6
75	0	0.5
76	2.3	2.4
77	0	0
78	2.7	2.7
79	4	4
80	0	0
81	2.6	5.2
82	1.3	2.4
83	2.3	2.5
84	0.6	2.4
85	0	0
86	2.3	2.2
87	2	2.2
88	2.3	2.2
89	2.3	2.2
90	5.1	5.1
91	2.3	2.2
92	2.3	2.2
93	2.3	2.2
94	2.3	2.2
95	0	0.3
96	5.1	5.1
97	0	0
98	2.5	2.5
99	0	0
100	2.5	3
IC 751		
1	5	5
2	1.5	1.5
3	1.5	1.5
4	0	0

MODE PIN NO.	EE	PLAY
5	2.3	2.3
6	2.2	2.2
7	0	0.5
8	0	0.5
9	0	0.5
10	0	0
11	5.1	5.1
12	4.6	4.7
13	4.3	4.3
14	0	2.5
15	0	2.5
16	0	5
17	0	0.5
18	0	0.5
19	5	5.1
20	0	0
21	0	0.5
22	5	5.5
23	0	0
24	0	0
25	0	0
26	0.5	0
27	0.5	0
28	0.4	0
29	0	0
30	2.8	2.8
31	2.8	2.8
32	0	0
33	5	5.1
34	4.2	4.1
35	0	0
36	2.8	2.7
37	0	0
38	0	0
39	0	0
40	2.7	2.7
41	2.8	2.7
42	2.6	2.6
43	2.8	2.7
44	0	0

	PB			REC		
	E	C	B	E	C	B
Q110	-20.28	-20.23	-19.51	-20.92	-20.86	20.14
Q111	5.25	5.12	0	5.25	5.19	0
Q112	12.09	12.95	12.74	12.12	13.22	12.76
Q113	5.25	5.21	4.48	5.25	5.19	4.47
Q114	31.65	31.53	30.96	32.5	32.4	31.82
Q115	0	0.13	0.76			

PRINTED CIRCUIT DIAGRAMS

1. MAIN P.C.BOARD

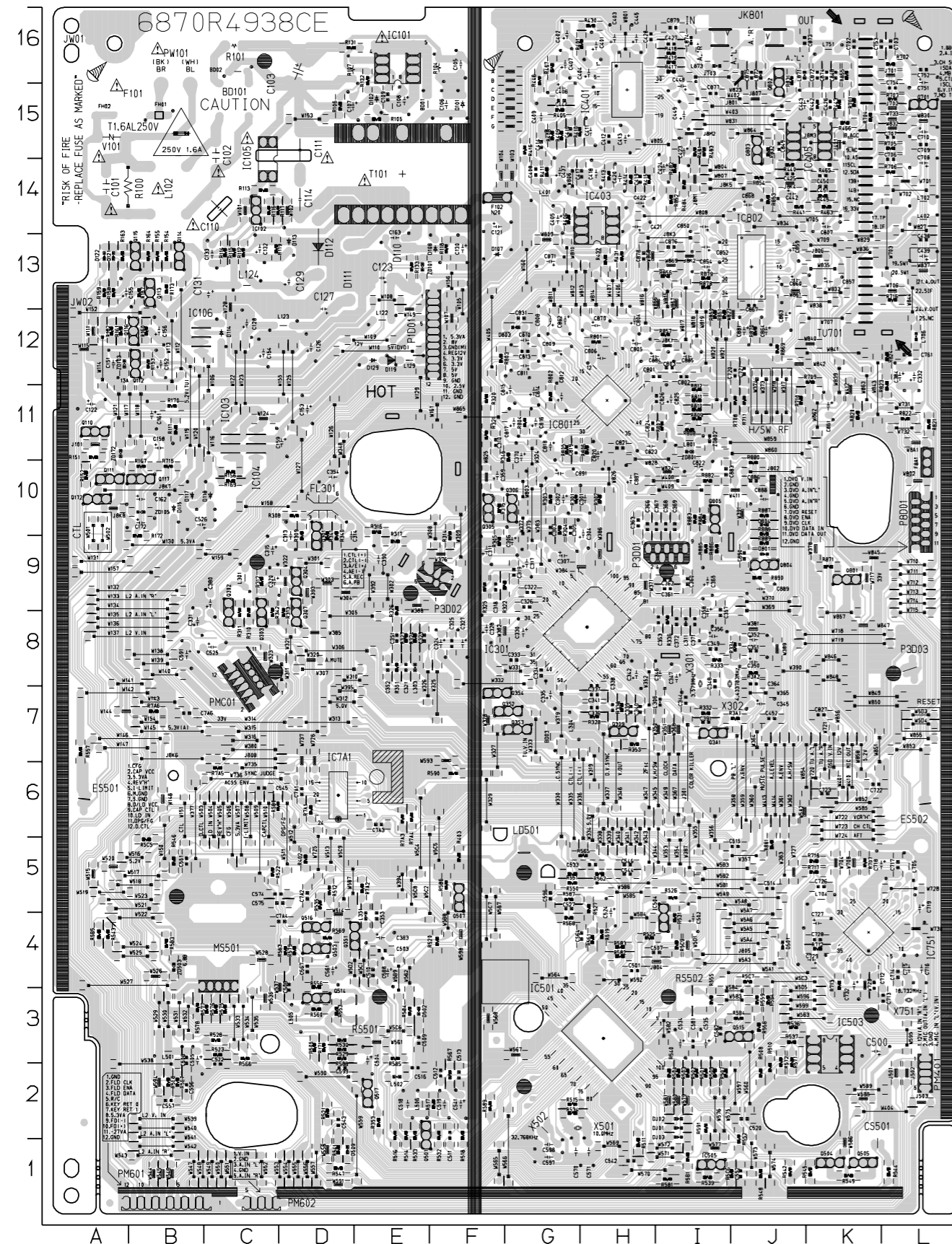

NOTES) ⚠ Warning
Parts that are shaded are critical
With respect to risk of fire or
electrical shock.

LOCATION GUIDE

B001	E15	C384	L12	C713	L3	D501	J4	Q301	O9	R403	F5	R583	H2
B002	C16	C390	E9	C714	L4	D502	E3	Q302	C8	R405	G15	R584	E3
B003	C7	C391	I7	C715	L4	D509	D1	Q303	C8	R406	G14	R585	E3
BD101	C15	C351	E8	C716	L4	D801	J9	Q304	O9	R408	G15	R586	F5
C101	A14	C352	E8	C717	L5	D803	G12	Q305	F10	R409	G15	R587	O5
C102	C15	C353	E4	C718	L5	D804	J10	Q306	G10	R410	G15	R588	F6
C103	D16	C401	H16	C719	L5	DJ01	I2	Q307	O8	R411	G14	R589	F2
C105	F16	C402	G16	C720	J12	DJ02	I2	Q309	H7	R413	H14	R590	F6
C106	F15	C403	H16	C721	J12	DJ03	I2	Q3A1	I7	R414	H14	R591	I2
C107	D15	C404	H16	C722	K6	E5501	A7	Q351	E4	R415	H14	R581	I1
C108	E15	C405	G14	C723	K6	E5502	L5	Q352	G7	R416	G15	R583	B4
C109	E15	C406	G15	C726	K5	F102	F14	Q353	G7	R417	I16	R584	J3
C110	C14	C407	G16	C727	K4	F8A1	L10	Q354	F7	R418	I16	R585	A4
C111	D15	C408	G14	C728	K4	F801	B15	Q501	E2	R419	I16	R585	B5
C114	D14	C409	G15	C729	K4	F802	A15	Q503	D4	R430	H16	R586	J1
C121	F14	C410	G15	C732	K4	FL301	D10	Q504	K1	R431	H13	R587	J4
C122	A11	C411	H15	C751	L6	IC101	E16	Q505	K1	R432	H13	R589	I4
C123	E13	C412	H15	C752	L16	IC102	C14	Q507	F5	R440	J14	R587	B2
C126	D12	C413	H15	C753	L16	IC103	C11	Q514	O3	R441	J14	R588	B2
C127	D12	C414	G15	C754	L15	IC104	C11	Q515	J3	R442	K15	R701	K15
C128	C12	C417	H14	C761	L12	IC105	C14	Q516	D4	R443	K15	R702	L16
C129	D13	C418	H14	C761	D6	IC106	B12	Q517	E2	R445	K14	R703	L15
C130	F13	C419	H14	C762	D5	IC403	H13	Q701	L15	R446	G16	R704	K15
C131	C13	C420	H14	C763	E6	IC405	J15	Q801	K9	R463	K14	R705	L15
C132	C13	C421	H14	C764	D4	IC503	K3	Q802	J16	R465	K14	R706	L14
C133	C13	C422	H14	C766	B7	IC504	I4	Q803	J15	R466	K15	R707	K5
C151	A12	C423	I15	C801	I12	IC505	I1	Q804	J9	R467	G16	R708	J11
C152	B12	C424	I14	C802	I12	J101	A11	Q805	I10	R481	I15	R709	K12
C153	D11	C425	J14	C803	I12	J301	I6	R100	A14	R482	I14	R710	J11
C154	C12	C426	K15	C804	H12	J401	K15	R101	C16	R483	I15	R711	J11
C155	A13	C427	I16	C805	H12	J501	L2	R104	F16	R484	I14	R712	K1
C156	B12	C428	H16	C806	H12	J502	L2	R105	C15	R501	I12	R713	K4
C158	B11	C437	G14	C807	K14	J503	L2	R106	D15	R502	I2	R715	B10
C159	D11	C438	L13	C808	G12	J701	L16	R107	D16	R503	I2	R716	L13
C161	B11	C439	L13	C809	G12	J702	L15	R111	B11	R504	I2	R717	K5
C162	B10	C442	J14	C810	G12	J703	I16	R112	C13	R505	D3	R718	H5
C163	E13	C443	J15	C811	G12	J801	J15	R113	C14	R507	I2	R7A1	D6
C172	B10	C444	G15	C812	G11	J802	J10	R114	C13	R508	J2	R7A2	E5
C301	H10	C445	H16	C813	G12	J804	I4	R115	C13	R509	I2	R7A3	E6
C302	G10	C448	I15	C814	G11	J805	I4	R116	C14	R510	J2	R7A4	E6
C303	G10	C449	I15	C815	G11	J806	K13	R117	C14	R511	H1	R7A5	C6
C304	H10	C450	K14	C816	G11	J807	J15	R118	F13	R512	D5	R7A6	B7
C305	G10	C451	K14	C817	G11	J808	C7	R119	C13	R514	E2	R801	H12
C306	G9	C452	J7	C818	G11	J8K1	I12	R131	D16	R515	G2	R802	G11
C307	G9	C500	K3	C819	G11	J8K2	I13	R132	E16	R516	E2	R803	F12
C310	F14	C501	H4	C820	H11	J8K3	I13	R133	E13	R517	F2	R804	G11
C311	F9	C502	I4	C821	H11	J8K4	J14	R151	A11	R518	F2	R805	G11
C313	D9	C503	E4	C822	I10	J8K5	I14	R152	A10	R519	H4	R806	H11
C314	D9	C504	E3	C823	H11	J8K6	B7	R153	B12	R520	F4	R807	I11
C315	C9	C505	B3	C824	H11	J8K7	B10	R154	B13	R521	D2	R808	I11
C317	G9	C506	B3	C825	I11	J8K8	A10	R155	B13	R522	C5	R809	I11
C318	F9	C507	I4	C826	I11	J8M1	I14	R156	C10	R523	C3	R810	I11
C319	G9	C508	D4	C827	K7	J8M2	I15	R157	B13	R525	H4	R811	I11
C320	C9	C509	E3	C831	G12	J8M3	K15	R158	A13	R526	I5	R812	I11
C321	E8	C510	E4	C848	K16	JK801	I16	R159	A13	R527	H5	R820	K11
C322	G9	C511	F2	C849	J15	JW01	A16	R160	B12	R528	C3	R821	L11
C323	E8	C512	F2	C850	I14	JW02	A13	R161	A12	R529	D3	R822	L11
C324	F8	C513	F2	C852	I13	L102	B14	R162	A12	R530	D3	R823	L11
C325	F8	C514	J5	C854	I13	L122	E12	R163	A13	R531	I4	R824	L12
C326	G9	C515	J5	C857	K13	L123	D12	R164	B13	R532	F2	R831	J16
C327	F8	C516	E2	C859	J13	L124	C13	R167	B10	R533	F2	R832	J15
C328	F8	C517	E2	C860	H12	J8K4	J14	R169	C10	R534	G2	R830	D2
C330	G8	C519	F2	C861	K11	L301	C9	R170	B11	R535	D5	R851	I12
C331	B8	C520	J2	C862	G12	L303	E8	R171	O3	R536	J3	R852	I14
C332	L12	C522	C2	C863	J12	L304	G7	R172	B9	R537	J3	R853	J14
C333	G8	C524	H4	C864	J12	L306	I7	R173	B13	R539	I1	R854	J14
C334	G8	C525	C8	C867	J13	L311	I8	R301	G10	R540	I2	R855	K16
C335	C7	C526	B10	C868	J14	L351	E4	R302	H10	R541	D1	R856	I13
C336	H7	C527	G5	C870	H12	L401	G14	R303	G10	R542	J1	R857	I12
C337	H7	C533	H5	C871	G13	L402	L14	R304	G10	R543	A4	R869	J12
C338	H7	C534	I3	C872	K16	L501	B3	R305	F9	R544	L1	R870	J12
C339	H7	C535	I3	C873	J16	L502	E2	R308	D10	R545	K1	R871	K9
C340	H7	C541	F2	C874	K16	L505	D3	R309	O9	R546	B5	R878	I13
C341	H7	C542	H1	C875	J16	L506	E2	R310	C8	R547	D1	R879	I13
C342	H8	C543	D2	C876	I13	L702	L14	R311	C8	R548	J1	R880	J10
C344	I7	C544	H5	C877	I13	L704	K5	R312	C9	R549	K1	R881	J5
C345	G7	C545	G8	C878	H13	L705	E8	R313	O8	R550	G5	R882	I10
C346	I8	C546	H5	C879	I16	L706	L12	R314	F9	R551	G5	R883	I10
C347	I8	C551	B5	C881	J12	L751	K16	R315	F10	R552	J1	R884	I10
C348	I8	C552	J1	C883	I10	L801	I11	R316	E10	R553	D3	R885	I9
C349	I8	C556	B2	C884	H12	L871	J16	R317	E9	R555	I3	R886	I9
C350	J8	C557	B2	C885	I12	L872	J16	R320	F11	R556	D4	R887	J10
C351	J8	C561	D4	C886	J10	L873	I16	R321	F11	R557	A7	R888	J10
C352	J8	C564	H4	C887	H10	L874	I16	R322	F9	R558	J3		

2. KARAOKE P.C.BOARD

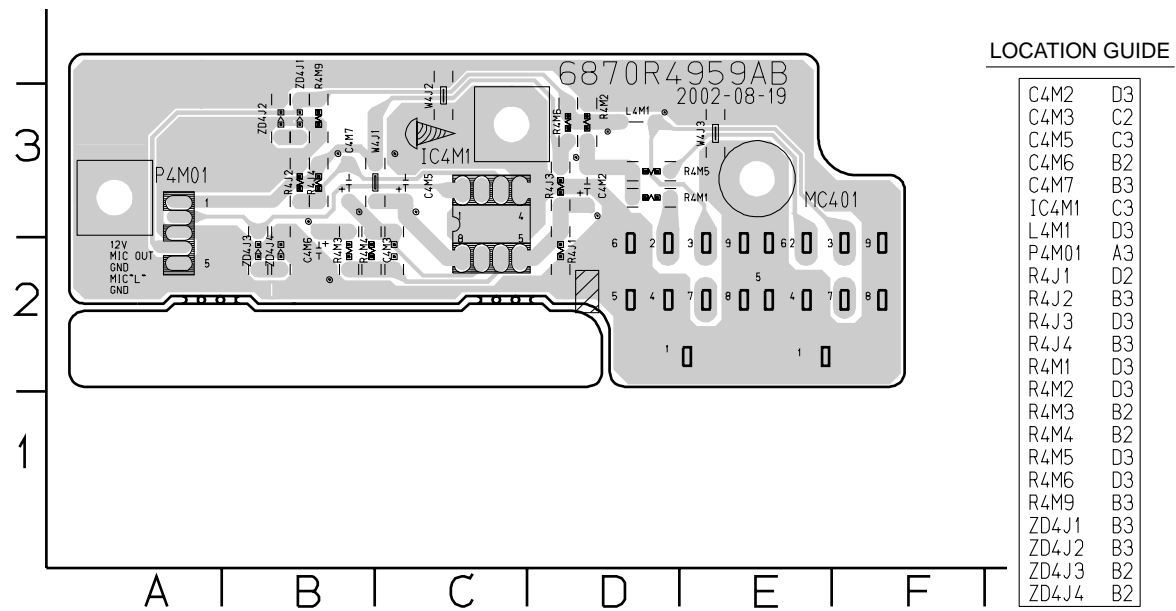

LOCATION GUIDE

C4M2	D3
C4M3	C2
C4M5	C3
C4M6	B2
C4M7	B3
IC4M1	C3
L4M1	D3
P4M01	A3
R4J1	D2
R4J2	B3
R4J3	D3
R4J4	B3
R4M1	D3
R4M2	D3
R4M3	B2
R4M4	B2
R4M5	D3
R4M6	D3
R4M9	B3
ZD4J1	B3
ZD4J2	B3
ZD4J3	B2
ZD4J4	B2

3. KEY P.C.BOARD

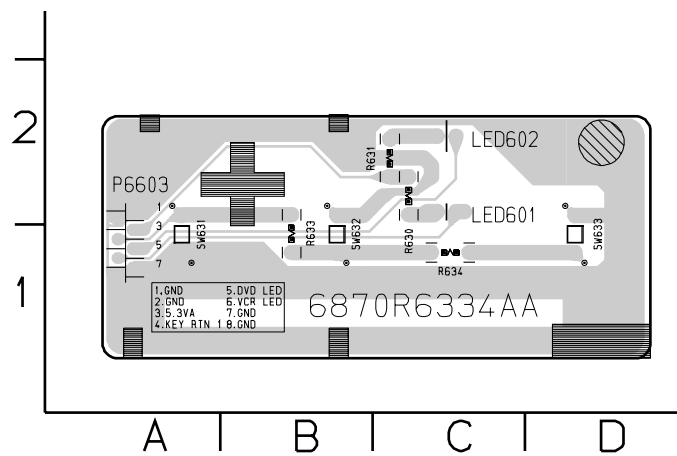

4. CLOCK P.C.BOARD

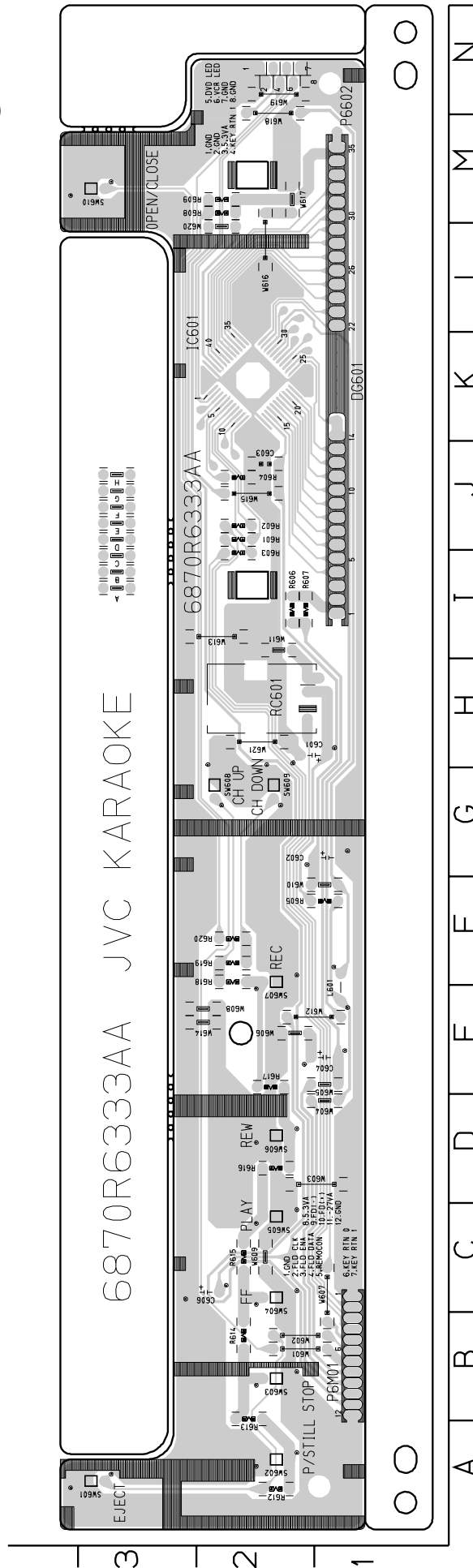

LOCATION GUIDE

C601	H2
C602	G1
C603	J2
C604	E1
C606	C2
DG601	K2
L601	E1
P6602	N2
P6M01	C1
R601	J2
R602	J2
R603	I2
R604	J2
R605	F1
R606	I2
R607	I2
R608	M2
R609	M2
R612	A2
R613	B2
R614	B2
R615	C2
R616	D2
R617	E2
R618	F2
R619	F2
R620	F2
RC601	H2
SW601	A3
SW602	A2
SW603	B2
SW604	C2
SW605	C2
SW606	D2
SW607	F2
SW608	G2
SW609	G2
SW610	M3

2. RF/CD DSP/DVD DSP/DVD SERVO BLOCK DIAGRAM

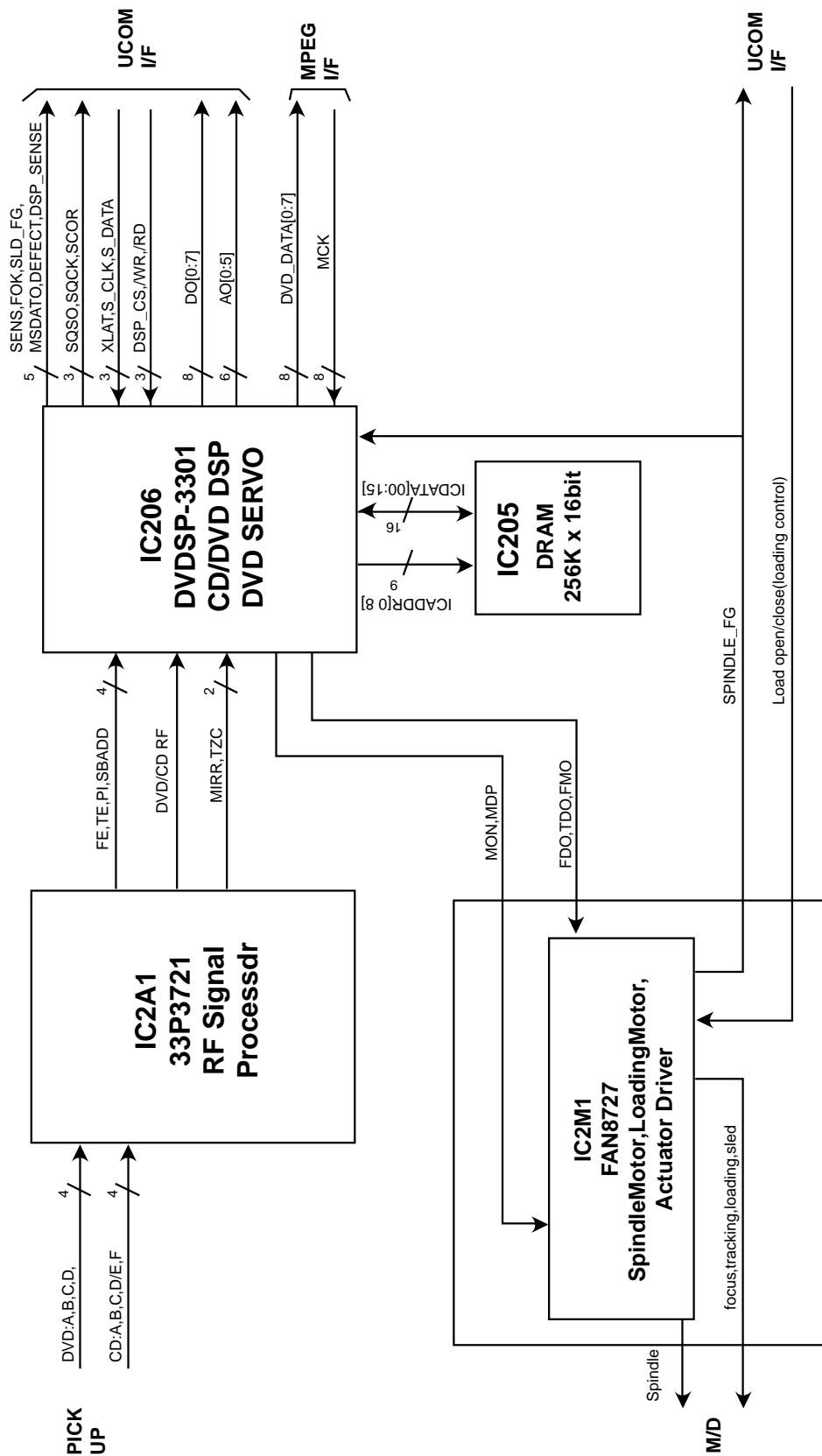

DV4000's

3. AUDIO BLOCK DIAGRAM

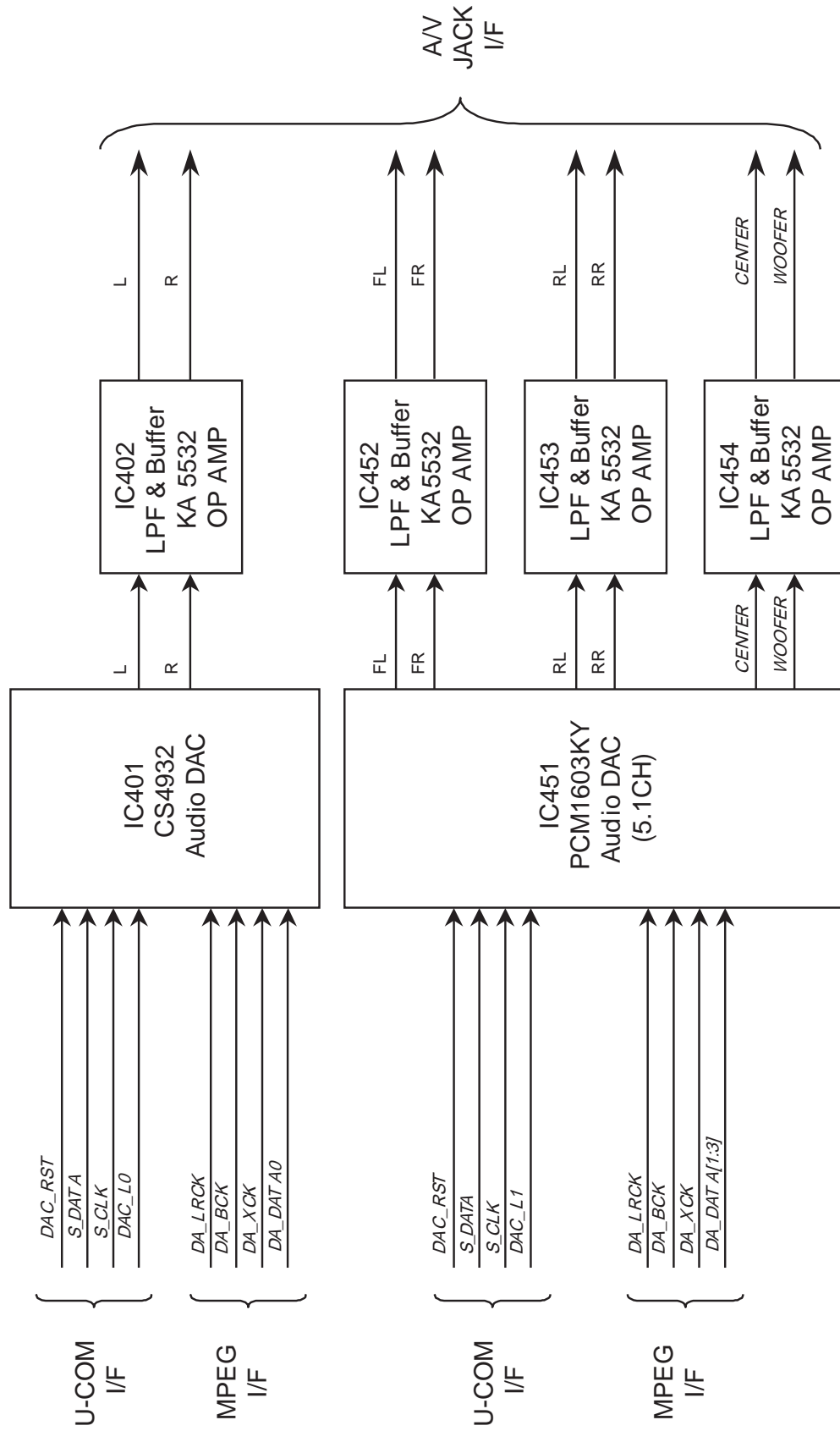

4. MPEG & MEMORY Block Diagram

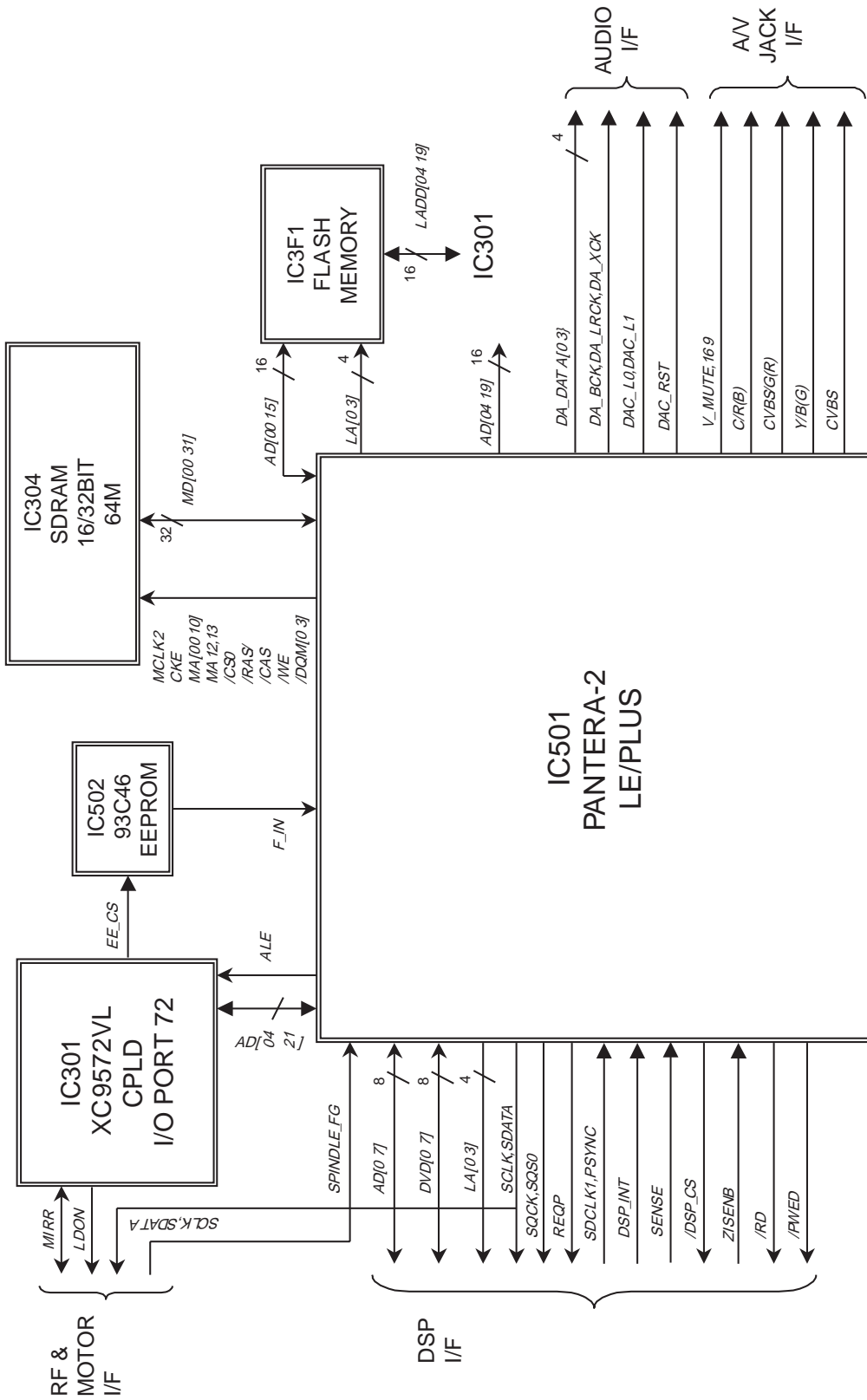

CIRCUIT DIAGRAMS

1. DVD DSP CIRCUIT DIAGRAM

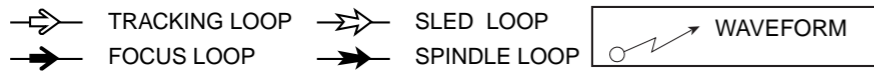
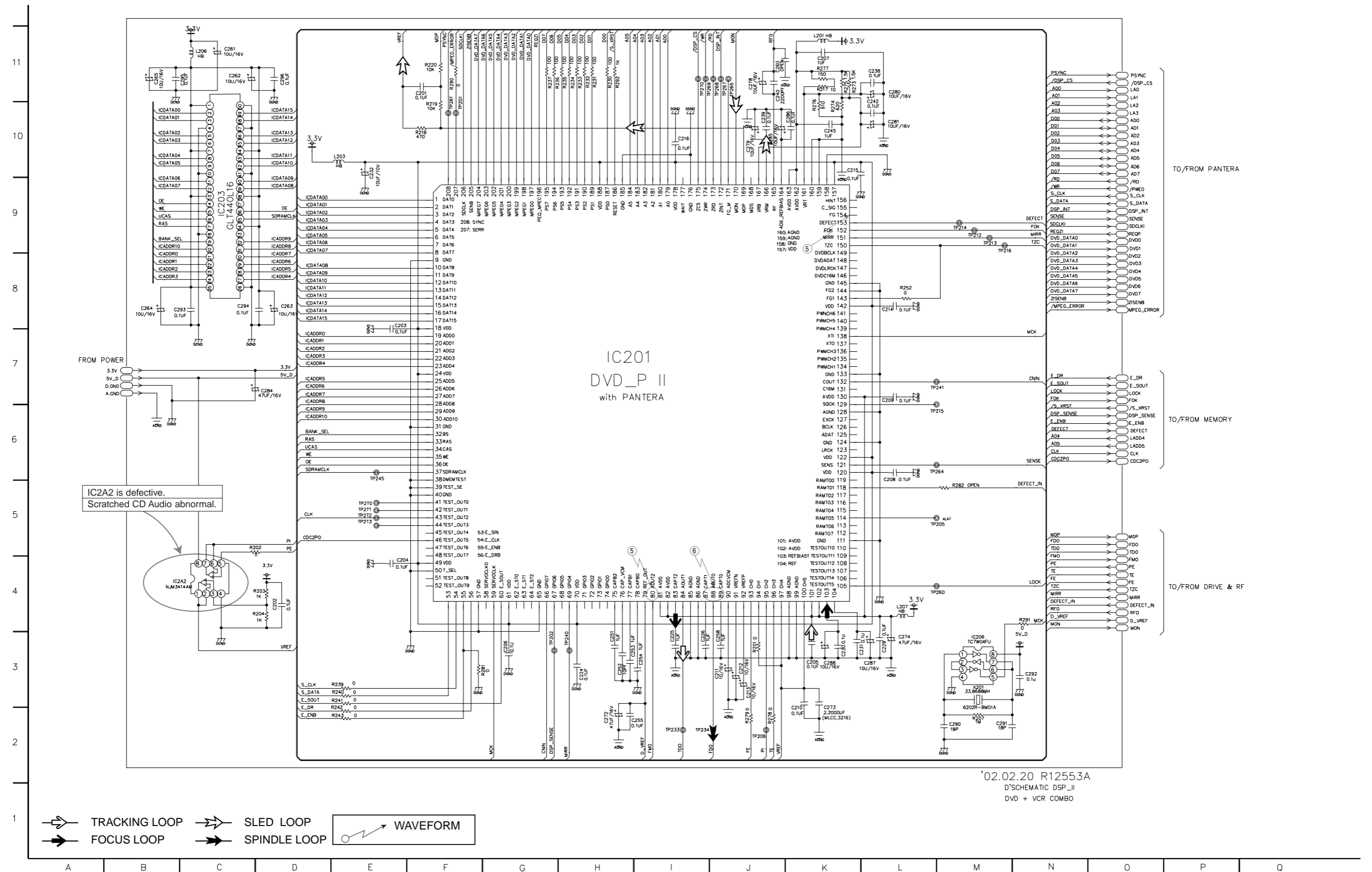

2. DRIVE & RF CIRCUIT DIAGRAM

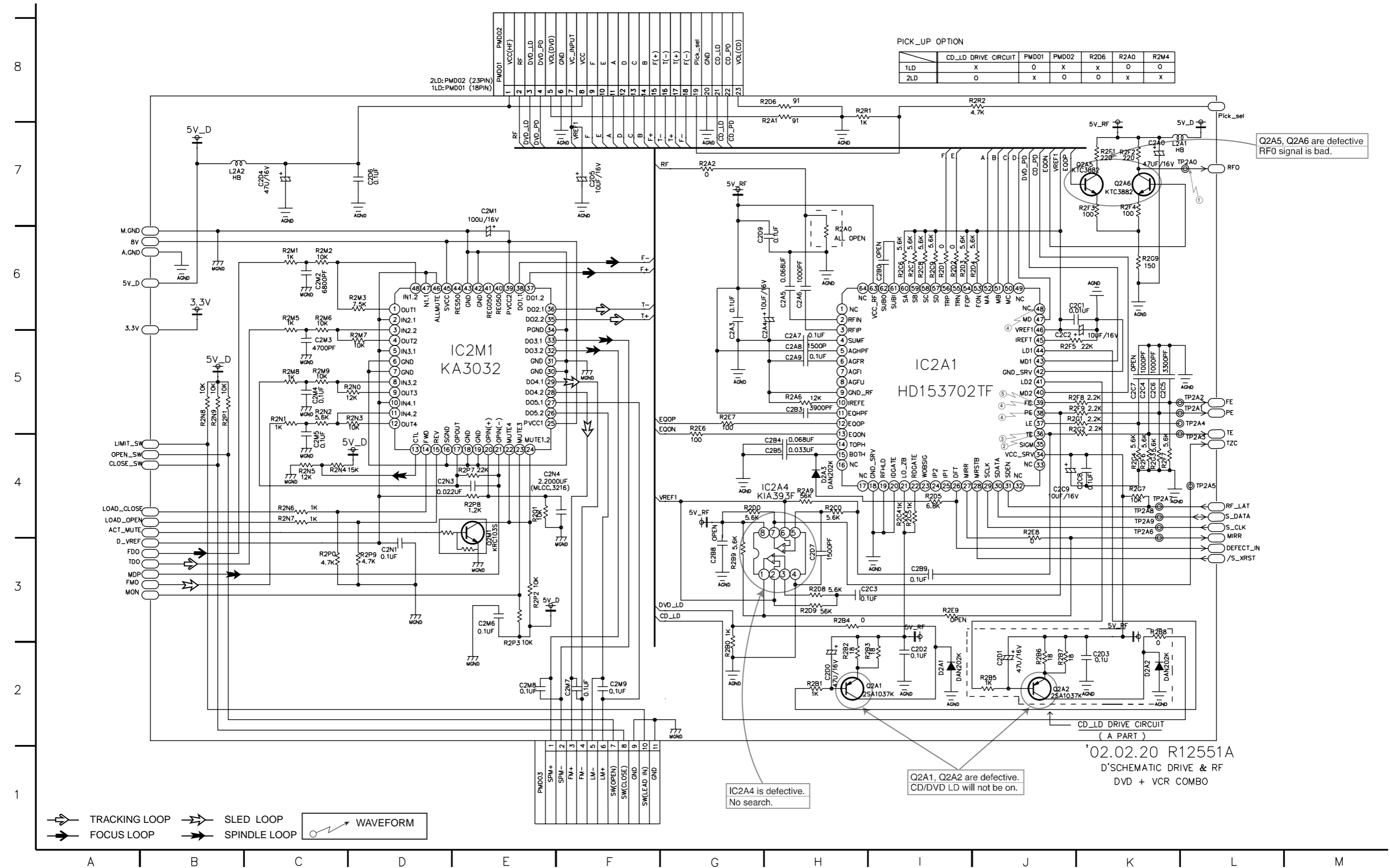

4. AUDIO DM CIRCUIT DIAGRAM

LOCATION GUIDE

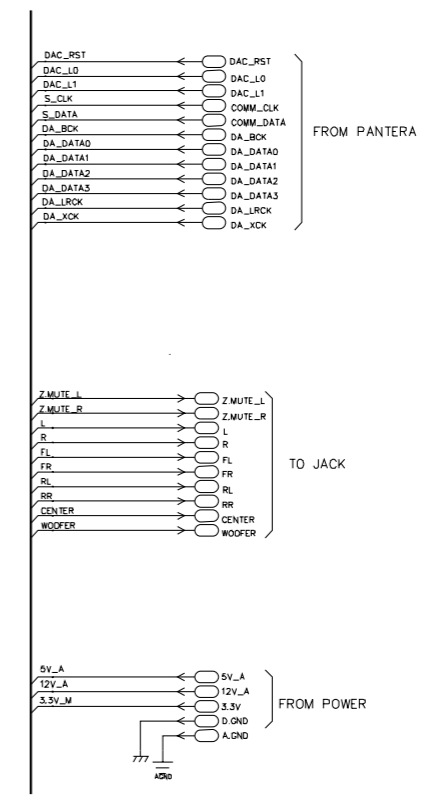
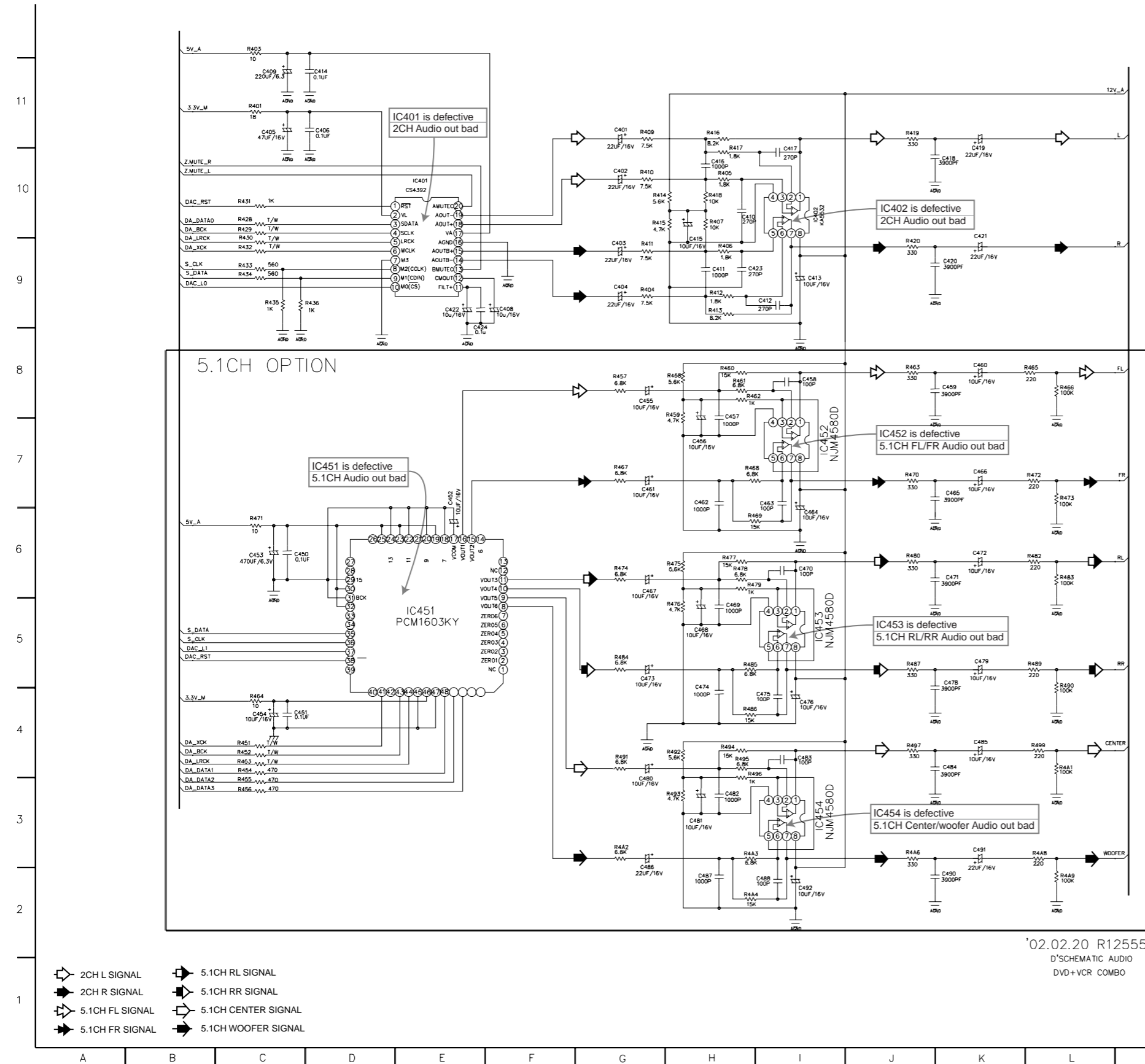

C401	G11	R433	C9
C402	G10	R434	C9
C403	G9	R435	C9
C404	G9	R436	D9
C405	C11	R451	C4
C406	D11	R452	C4
C408	F9	R453	C4
C409	C11	R454	C4
C410	H10	R455	C3
C411	H9	R456	C3
C412	I9	R457	G8
C413	I9	R458	H8
C414	D11	R459	H8
C415	H9	R460	H8
C416	H10	R461	H8
C417	I10	R462	H8
C418	K10	R463	J6
C419	K10	R464	C4
C420	K9	R465	K8
C421	K10	R466	L8
C422	E9	R467	G7
C423	H9	R468	H7
C424	E8	R469	H6
C450	C6	R470	J7
C451	C4	R471	C6
C452	E7	R472	L7
C453	C6	R473	L7
C454	C4	R474	G6
C455	G8	R475	H6
C456	H7	R476	H5
C457	H7	R477	H6
C458	I8	R478	H6
C459	K8	R479	H6
C460	K8	R480	J6
C461	G7	R482	L6
C462	H7	R483	L6
C463	I7	R484	C5
C464	I6	R485	H5
C465	K7	R486	H4
C466	K7	R487	J5
C467	G6	R489	L5
C468	H5	R490	L5
C469	H5	R491	G4
C470	I6	R492	H4
C471	K6	R493	H3
C472	K6	R494	H4
C473	C5	R495	H4
C474	H4	R496	H4
C475	I4	R497	J4
C476	I4	R499	L4
C478	K5	R4A1	L4
C479	K5	R4A2	G3
C480	G3	R4A3	H3
C481	H3	R4A4	H2
C482	H3	R4A6	J3
C483	I4	R4A8	L3
C484	K4	R4A9	L2
C485	K4		
C486	G2		
C487	H2		
C488	I2		
C490	K2		
C491	K3		
C492	I2		
IC401	E10		
IC402	I10		
IC451	E5		
IC452	I7		
IC453	I5		
IC454	I3		
R401	C11		
R403	C12		
R404	G9		
R405	H10		
R406	H9		
R407	H10		
R409	G11		
R410	G10		
R411	G9		
R412	H9		
R413	H9		
R414	G10		
R415	G10		
R416	H10		
R417	H10		
R418	H10		
R419	J11		
R420	J9		
R428	C10		
R429	C10		
R430	C9		
R431	C10		
R432	C9		

'02.02.20 R12555A
D'SCHEMATIC AUDIO
DVD+VCR COMBO

5. MEMORY CIRCUIT DIAGRAM

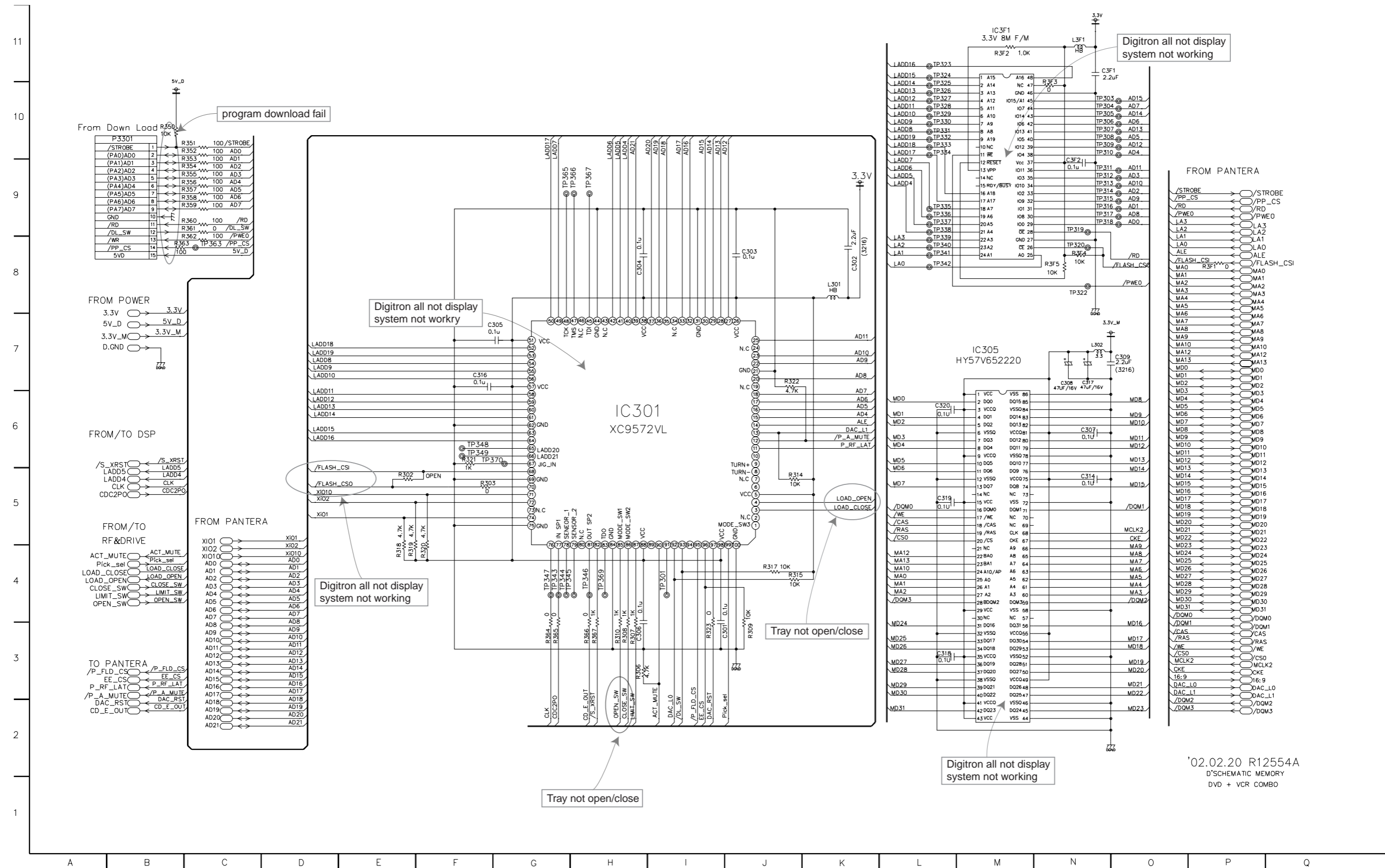

6. SCART(JACK) CIRCUIT DIAGRAM

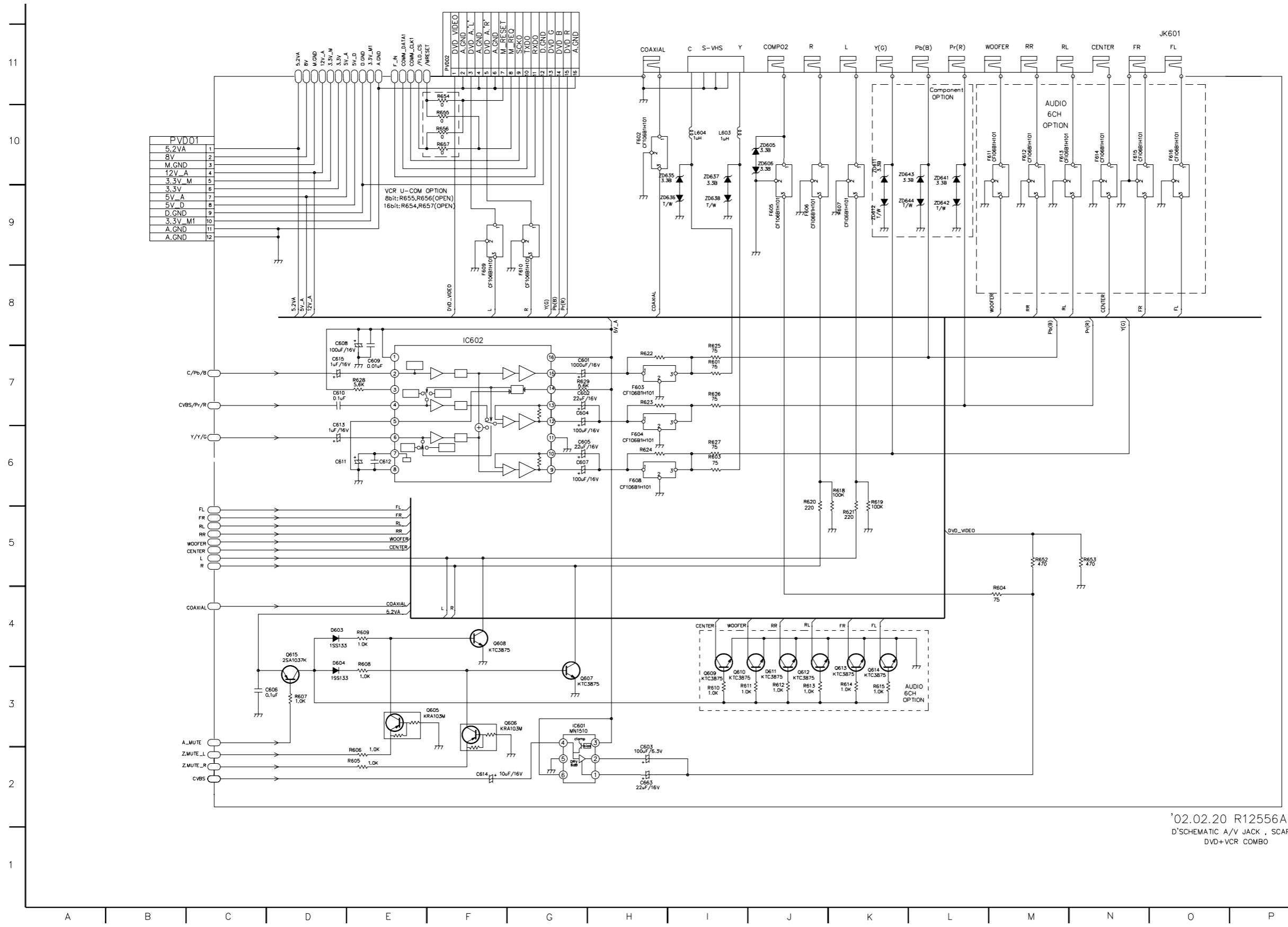

LOCATION GUIDE

C601	G7
C602	G7
C603	H2
C604	G7
C605	G3
C606	C3
C607	G6
C608	D8
C609	E7
C610	D7
C611	D6
C612	E6
C613	D6
C614	F2
C615	D7
C663	H2
D603	D4
D604	D4
F602	H10
F603	H7
F604	H6
F605	J9
F606	J9
F607	K9
F608	H6
F609	F8
F610	G8
F611	M10
F612	M10
F613	M10
F614	N10
F615	N10
F616	O10
IC601	G3
IC602	F8
JK601	O11
L603	I10
L604	I10
PVD01	B10
PVD02	F11
Q605	F3
Q606	F3
Q607	G3
Q608	F4
Q609	I3
Q610	I3
Q611	J3
Q612	J3
Q613	K3
Q614	K3
Q615	D4
R601	I7
R603	I6
R604	M4
R605	E2
R606	E2
R607	D3
R608	E4
R609	E4
R610	I3
R611	I3
R612	J3
R613	J3
R614	K3
R615	K3
R618	K6
R619	K6
R620	J6
R621	K5
R622	H7
R623	H7
R624	H6
R625	I7
R626	I7
R627	I6
R628	E7
R629	G7
R652	M5
R653	N5
R654	F11
R655	F10
R656	F10
R657	F10
ZD605	J10
ZD606	J10
ZD611	K10
ZD612	K9
ZD635	H10
ZD636	H9
ZD637	I10
ZD638	I9
ZD641	L10
ZD642	L9
ZD643	K10
ZD644	K9

'02.02.20 R12556A
D'SCHEMATIC A/V JACK , SCART
DVD+VCR COMBO

• WAVEFORMS

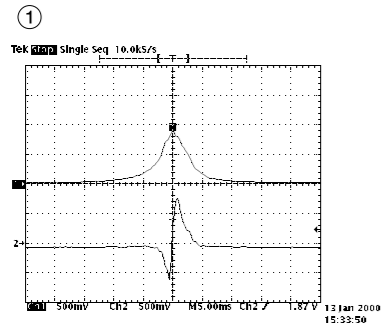

IC2A1 Pin 39, Focus Error
IC2A1 Pin 38, PE

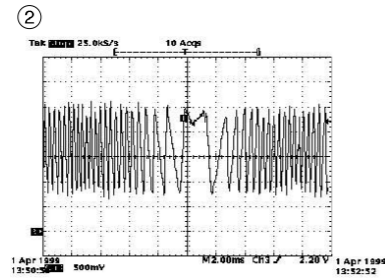

IC2A1 Pin 36
Tracking Error

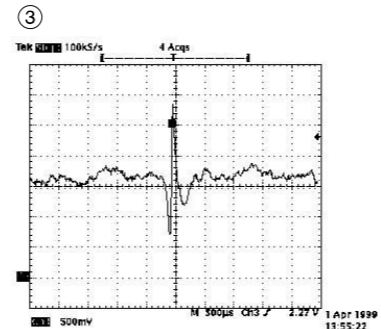

IC2A1 Pin 36
VBR TRACKING Error

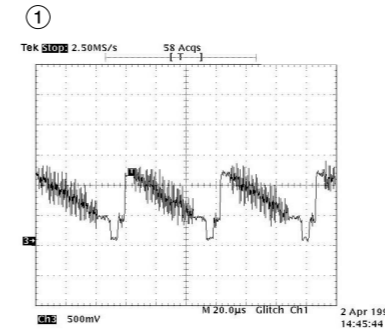

IC501 Pin 118, Composite

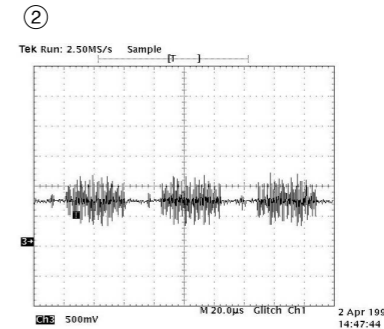

IC501 Pin 112, Chrominance
(Super video out Mode)

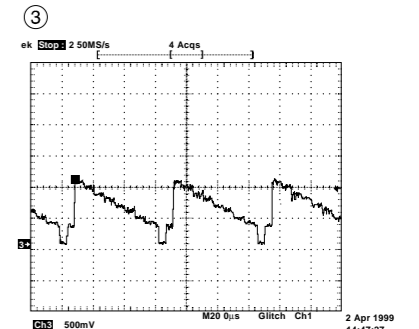

IC501 Pin 114, Luminance
(Super video out Mode)

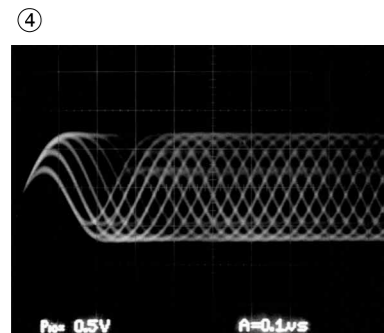

Q2A6 Collector output(TP2AO)
RF

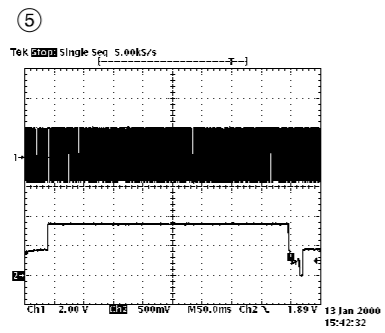

IC201 Pin 80, SLED FG
IC201 Pin 154, SLED FMO

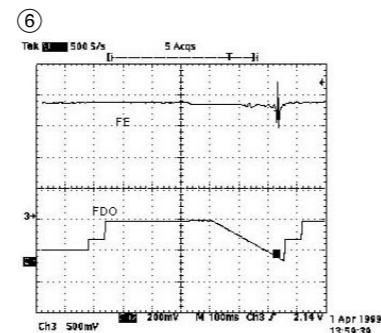

IC2A1 Pin39, Focus Error(in Focus Search)
IC201 Pin 88, Focus Drive(FDO)

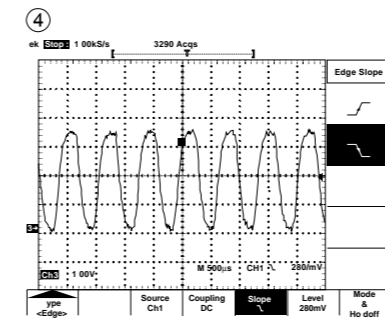

IC501 Pin 98,
MPEG Clock(27MHz)

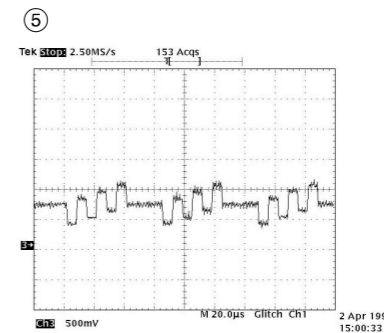

IC501 Pin 112
Component Pb

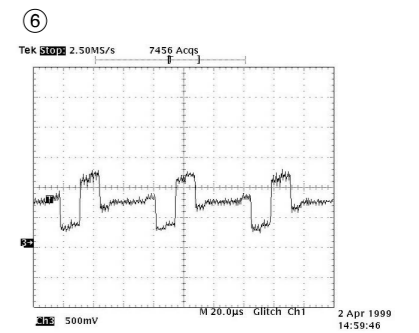

IC501 Pin 110
Component Pr

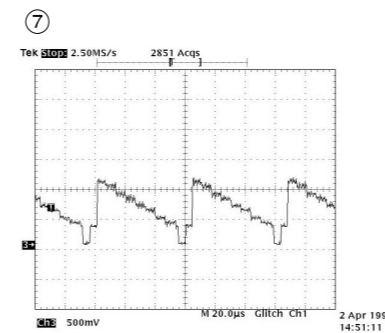

IC501 Pin 114
Component Y

• CIRCUIT VOLTAGE CHART

PIN	IC203		IC201		IC301		IC3F1		IC501		IC305		IC2A1		IC2M1	
	STOP	PLAY	STOP	PLAY	STOP	PLAY	STOP	PLAY	STOP	PLAY	STOP	PLAY	STOP	PLAY	STOP	PLAY
1	3.18	3.16	3.12	0	3.17	3.16	0	0	3.12	3.1	3.06	3.05	0	0	2.11	2.14
2	3.12	2.69	3.12	0	0	0	0	0	0.41	0.29	0.35	3.16	3.13	2.1	2.12	
3	3.12	2.69	3.12	0	3.16	0	0	0	0.47	3.06	3.05	3.16	3.13	2.11	2.11	
4	0	0	3.12	0	3.16	0	0	0	1.75	1.73	3.06	0.33	0.75	1.55	2.1	2.15
5	3.12	2.74	3.12	3.12	3.17	3.16	0	0	0.49	0	0	2.04	3.02	2.1	2.12	
6	3.12	2.71	3.12	3.12	3.17	3.16	0	0	0	0	0	0	0	0	0	
7	3.18	3.17	3.12	0	0	0	0	0	0.37	0	0.34	0	0	0	0	
8	3.12	2.68	3.12	3.12	3.17	3.16	0	0	0.35	0.4	0	0	0.33	2.11	2.12	
9	3.12	2.63	0	0	0	0	3.13	2.92	0	0.33	0	3.05	0	2.02	1.99	
10	0	0	3.12	3.12	0	0	0	0	3.22	3.19	0.33	0	0.44	0	2.1	2.12
11	3.12	2.7	3.12	3.12	0	0	3.13	3.12	0	0	0.41	0	1.72	1.19	2.11	2.12
12	3.12	2.7	3.12	0	0	0	3.2	3.2	0	0	0	0	2.06	2.3	2.09	2.13
13	3.18	3.17	3.12	3.12	3.17	3.16	3.2	3.2	0	0	0	0.46	2.25	3.08	3.25	2.23
14	0	0	3.12	0	0	0	0	0	0	0	0	0	1.32	3.13	2.51	0
15	3.12	3.04	3.12	0	0	0	0	0	0.79	3.06	3.05	1.46	2.27	2.51	0	
16	3.12	0	3.12	0	2.17	2.18	3.19	0	0	0.74	0	0	2.4	0	0	
17	3.12	3.02	3.12	0	0.38	2.21	0	0	0	3.09	3.07	0	0	2.18	0	
18	0	0	3.13	3.12	0.41	0.61	0	0	0	0.71	0	2.82	0	0	0	
19	0	0	3.13	0	0	0	0	0	3.22	3.1	2.84	3.03	0	0	0	
20	0	3.12	0	0	0	0	0	0	3.22	3.13	3.05	2.76	0	0	1.52	1.89
21	3.13	0	3.13	0	0	0	0	0	3.22	3.13	0	0	3.01	5.01	1.88	1.89
22	3.13	3.17	0	0	0	0	0	1.64	0	0	1.38	3.85	5.01	0	0	
23	3.13	0	0	0	0	0	0	0	0	0.8	0.79	0	0	3.13	0	
24	0	0	3.13	0	0	0	0	0	3.22	3.13	0	0	0	0	0	
25	3.18	0	3.12	0	0	0	3.11	3.11	0	3.13	1.14	1.1	0	0	7.95	7.92
26	0	0	0	0	3.21	3.16	3.17	3.2	0	3.13	0.38	1.54	3.31	3.63	3.92	3.71
27	0	0	0	3.12	0	0	0	0	3.22	3.11	0	0	0	0	3.92	3.71
28	3.12	0	0	0	0	0	3.11	0	0	1.1	0	0	3.14	3.16	3.9	3.74
29	0	3.12	0	0	0	0	0.61	1.07	0	0	0	0.05	5.15	5.14	3.95	3.68
30	0	0	0	0	0	0	0	0	0	0	0	0	0	0	0	
31	0	3.17	0	3.12	0	0	0.6	0	0	0	0	0	0	0	0	
32	0	0	0	0	0	0	0	0	3.22	1.39	0	0	0	0	1.18	4.2
33	3.1	0	3.12	0	0	0	0.59	0	3.22	0.8	0	0	0	0	1.18	3.43
34	3.18	0	3.12	0	0	0	0	0	1.75	1.52	0.34	0	5.03	4.99	0	0
35	1.5	0	3.12	0	0	0	0.61	0	3.22	2.76	3.03	3.05	2.29	2.34	3.92	3.75
36	0	3.12	0	0	0	0	0	0	3.22	3.11	0	0.34	2.2	2.3	3.93	3.73
37	0	0	1.51	0	0	0	3.18	0	3.22	3.03	0	0	2.2	2.2	3.92	3.73
38	3.18	0	0	0	3.17	3.16	0	0	3.22	2.83	0	0	2.29	2.26	3.92	3.68
39	3.12	3.12	0	0	0	0	0	0	3.22	3.08	0.56	0	2.24	2.24	7.95	7.94
40	3.12	3.12	0	0	0	0	2.17	0	0	0.56	0	0	0	7.91	7.87	
41	0	3.17	0	0	0	0	0	0	0	0	3.05	5.03	5.01	0	0	
42	3.12	0	0	0	0	0	0.38	2.28	0	0	3.03	0.45	0	0	0	
43	3.12	0	0	0	0	0	0	0	0	0.34	3.03	3.05	0	0	0	
44	3.18	0	0	0	0	0	0.41	0.65	3.22	3.11	0	0	5.03	1.59	0	0
45	3.12	3.12	0	0	3.17	3.15	0	0	0.45	0.33	0	0.44	2.3	2.3	7.95	7.94
46	2.76	3.12	1.56	0	0	0	0	0	0	0	0	2.3	2.3	2.11	2.12	
47	0	0	0.91	0	3.17	3.15	0	0	0	0	0.38	0	1.74	2.3	2.1	2.12
48	3.12	1.65	0	2.19	0	0	0	0	0	0	0	0	0	2.11	2.12	
49	3.12	3.14	0.53	0	0	0	0	0	0	3.03	0	0	0	0	0	
50	0	0	0	0	0	0	0	0	0.43	0.39	0.36	3.05	2.3	2.3	0	
51	0	0.64	0	3.17	0	0	0	0	0.42	0.45	0	0.34	2.3	2.3	0	
52	0	0.43	0	3.17	3.19	0	0	0	0.43	0.35	0	0	2.3	2.3	0	
53	0	0	0	3.11	2.91	0	0	0	3.12	3.11	0	0	2.3	2.3	0	
54	0	2.58	0	0	0	0	0	0	0	0.41	0	0	2.3	2.3	0	
55	0	0	0	0	0	0	0	0	0	0.33	3.03	3.05	2.3	2.3	0	
56	0	3.11	0	0	0	0	0	0	0.39	0.36	0	0.34	2.3	2.3	0	
57	0	0	0	3.17	3.19	0	0	0	0	0	0	0	2.3	2.3	0	
58	0	1.65	0	0	0	0	0	0	0	0	0	0	2.3	2.3	0	
59	0	1.79	0	0	0	0	0	0	0	0.42	0	0	2.29	2.3	0	
60	0	0	0	0	0	0	0	0	0.44	0.4	0	0.79	2.29	2.3	0	
61	0	3.13	0	0	0	0	0	0	0.44	0.47	0	0.79	0.36	0.56	0	
62	0	0	0	0	0	0	0	0	3.12	3.11	0	2.26	0.37	0.62	0	
63	0	3.13	0	0	0	0	0	0	0.45	0.35	0	0.74	5.03	5.02	0	
64	0	0	0	0	0	0	0	0	0	0	0	0.78	0	0	0	
65	0	0	0	0	0	0	0	0	0	0	0	0	0	0	0	
66	0	3.12	0	0	0	0	0	0	0	0	0	0	0	0	0	
67	0	0	0	0	0	0	0	0	0	0.31	3.11	3.1	0	0	0	
68	0	3.13	3.12	3.11	3.1	0	0	0	1.51	0	1.6	1.59	0	0	0	
69	0	4.08	0	0	0	0	0	0	0	1.5	0	0	0	0	0	
70	0	3.13	0	0	3.16	0	0	0	1.47	0	0	0	0	0	0	
71	0	0	0	3.11	3.1	0	0	0	0	0	0	0	0	0	0	
72	0	3.13	3.13	0	0	0	0	0	0	0	0	0	0	0	0	
73	0	0	0	0	0	0	0	0	0	0	0	0	0	0	0	
74	0	0	0	3.11	3.1	0	0	0	0	0	0	0.45	0	0	0	
75	0	0.78	0	0	0	0	0	0	3.12	3.11	3.04	3.05	0	0	0	
76	0	1.41	0	0	0	0	0	0	1.48	1.26	0	0	0	0	0	
77	0	0.77	0	0	0	0	0	0	1.74	1.74	0	0	0	0	0	
78	0	0.77	0	0	0	0	0	0	1.54	1.54	0	0	0	0	0	
79	0	2.1	2.11	3.17	0	0	0	0	1.56	1.55	0	0	0	0	0	
80	0	2.12	2.11	0	0	0	0	0	3.11	3.1	0	0.34	0	0	0	
81	0	3.18	0	3.17	0	0	0	0	3.01	3.01	1.69	0	0	0	0	

PIN	IC203		IC201		IC301		IC3F1		IC501		IC305		IC2A1		IC2M1	
	STOP	PLAY	STOP	PLAY	STOP	PLAY	STOP	PLAY	STOP	PLAY	STOP	PLAY	STOP	PLAY	STOP	PLAY
82			3.18	0	3.17	3.19			0	0	0	0				
83			1.93	1.93	2.12	2.27			0	0.33	0	0				
84			2.11	2.11	0	0			1.74	5.12	0	0				
85			0	0	4.41	4.41			0	0	0	0.33				
86			0	0	0	0			0	0	0	0				
87			1.93	0	0	0			1.42	3.11						
88			2.1	0	3.17	3.19			1.87	3.11						
89			1.93	1.92	2.66	0			1.67	1.74						
90			1.59	0	0	3.17			0	0						
91			0.8	0	3.19	0			3.11	3.11						
92			2.36	2.36	3.19	3.19			0	3.11						
93			2.24	1.6	3.19	3.19			3.11	3.11						
94			1.58	1.56	0	0			0	0.34						
95			1.64	1.62	3.13	3.13			0	0.34						
96			1.58	1.62	0	0			2.82	3.11						
97			1.58	1.56	3.19	3.19			0	0						
98			0	0	3.19	3.19			0.85	0.92						
99			0	0												

PIN	IC901		IC451		IC401		IC454		IC453		IC452		IC402		IC801	
	STOP	PLAY	STOP	PLAY	STOP	PLAY	STOP	PLAY	STOP	PLAY	STOP	PLAY	STOP	PLAY	STOP	PLAY
1	0	0	0	0	2.98	2.98	5.51	5.51	5.41	5.42	5.49	0	5.47	5.47	1.83	1.81
2	5.1	5.05	3.15	3.15	3.26	3.26	5.51	5.51	5.41	5.42	5.49	5.51	5.47	5.47	0	0
3	0	0	3.15	3.15	0	0	5.51	5.51	5.41	5.41	5.49	5.51	5.47	5.47	1.83	1.81
4	5.14	5.14	3.15	3.14	1.57	0	0	0	0	0	0	0	0	0	0	0
5	0.48	0	3.15	3.15	1.58	1.58	5.51	5.51	5.41	5.41	5.49	5.51	5.47	5.47	0	0
6	0.48	0	3.15	3.15	1.3	0	5.51	5.51	5.41	5.42	5.49	5.51	5.47	5.47	4.59	4.57
7	5.17	5.17	3.15	3.15	0	0	5.51	5.51	5.41	5.41	5.49	0	5.47	5.47	1.84	1.82
8	2.22	2.21	2.43	2.42	3.24	3.24	11.95	11.95	11.95	11.95	11.95	11.95	11.95	11.95	0	0
9	2.35	2.35	2.48	2.46	0	0									1.84	1.82
10	0	0	2.43	2.42	3.2	3.19										
11	2.26	2.24	2.48	0	4.85	4.84										
12	2.46	2.45	0	0	2.31	0										
13	0	0	0	0	2.35	0										
14	5.17	5.16	0	0	2.35	0										
15	5.17	5.16	2.43	2.43	0	0										
16	5.1	5.06	2.47	3.14	0	0										
17	0	0	2.45	0	4.91	0										
18	0	0	0	0	2.34	2.34										
19	5.16	5.16	4.91	4.88	2.34	2.33										
20	5.14	5.14	0	0	0	0										
21	5.01	5.02	0	0												
22	0	0	0	0												
23	0	0	4.91	0												
24	0	0	0	0												
25	2.68	2.68	4.9	4.88												
26	5.17	5.17	0	0												
27	5.17	5.17	0	0												
28	4.77	4.87	0	0												
29	5.07	5.06	0	0												
30	21.58	18	4.91	4.88												
31	23.58	18	0	0												
32	23.6	23	4.91	4.88												
33	27.54	21.21	0	0												
34	23.6	17.18	0.36	0												
35	23.6	22.91	0	0												
36	21.6	19.14	3.24	3.23												
37	21.61	25.01	3.19	3.19												
38	23.65	23.06	2.93	3.92												
39	23.65	23.09	0	0												
40	23.57	23.08	0	0												
41	25.6	23.07	1.3	1.31												
42	25.6	25.03	1.48	1.47												
43	25.6	25.03	1.57	0												
44	25.6	23.07	1.58	1.58												
45	27.6	25.07	0	0												
46	27.6	21.16	3.15	3.15												
47	27.5	25.11	0	0												
48	27.5	24.76	0	0												
49	27.5	27.86	0	0												
50	27.5	26.88	0	0												
51	6.73	6.69	3.15	3.14												
52	25.7	25.13	0	0												
53	25.6	25.08														
54	25.6	25.16														
55	25.6	25.15														
56	25.6	25.08														
57	25.6	25.13														
58	27.7	27.08														
59	5.16	5.15														
60	5.16	5.16														
61	5.16	5.16														
62	5.16	5.16														
63	0	0														
64	0	0														

PIN	IC503		IC502		IC2A4		IC2A2		IC206		IC504		IC506	
	STOP	PLAY	STOP	PLAY	STOP	PLAY	STOP	PLAY	STOP	PLAY	STOP	PLAY	STOP	PLAY
1	0	0	0	0	4.87	4.39	1.57	1.56	2.63	2.64	2.11	2.19	(IN)0	0
2	3.1	3.1	5.03	5.03	2.3	2.31	1.57	1.56	2.74	0	5.05	5.05	(OUT)1.80	0
3	5.03	5.03	0	0	2.29	2.29	1.57	0	2.74	2.76	2.37	2.44		
4	0	0	5.1	5.1	0	0	0	0	0	0	0	0		
5	0	0	0	0	2.29	2.29	1.62	1.62	1.92	1.88				
6	0	0	5.04	5.04	2.3	2.31	1.62	1.62	2.28	0				
7	5.05	5.05	0	0	2.51	2.45	1.62	1.62	2.28	0				
8	0	3.15	5.03	5.04	5.02	5.02	5.04	4.99	5.04	0				
9	0	0												
10	0	0												
11	0	0.46												
12	0	0.15												
13	3.11	3.1												
14	0	0												
15	0	0												
16	0	0												
17	3.09	3.09												
18	5.15	5.14												
19	0	0												
20	5.15	5.15												

	Q2M1		Q2A1		Q2A6		Q2A5		Q2A2	
	STOP	PLAY	STOP	PLAY	STOP	PLAY	STOP	PLAY	STOP	PLAY
E	0	0	5.02	0	0	2.41	2.34	2.35	5.02	4.95
B	0	0	0	0	3.62	3.72	3.82	0	0	0
C	0	3.14	0	0	0	3.1	0	0	5.01	4.94

PIN	Q610		Q611		Q609		Q613		Q614		Q612	
	STOP	PLAY	STOP	PLAY	STOP	PLAY	STOP	PLAY	STOP	PLAY	STOP	PLAY
Emitter	0	0	0	0	0	0	0	0	0	0	0	0
Collector	0	0	0	0	0	0	0	0	0	0	0	0
Base	0.77	0.78	0.77	0.77	0.76	0.77	0.76	0.77	0.77	0.77	0.76	0.79

1. MAIN P.C.BOARD (BOTTOM VIEW)

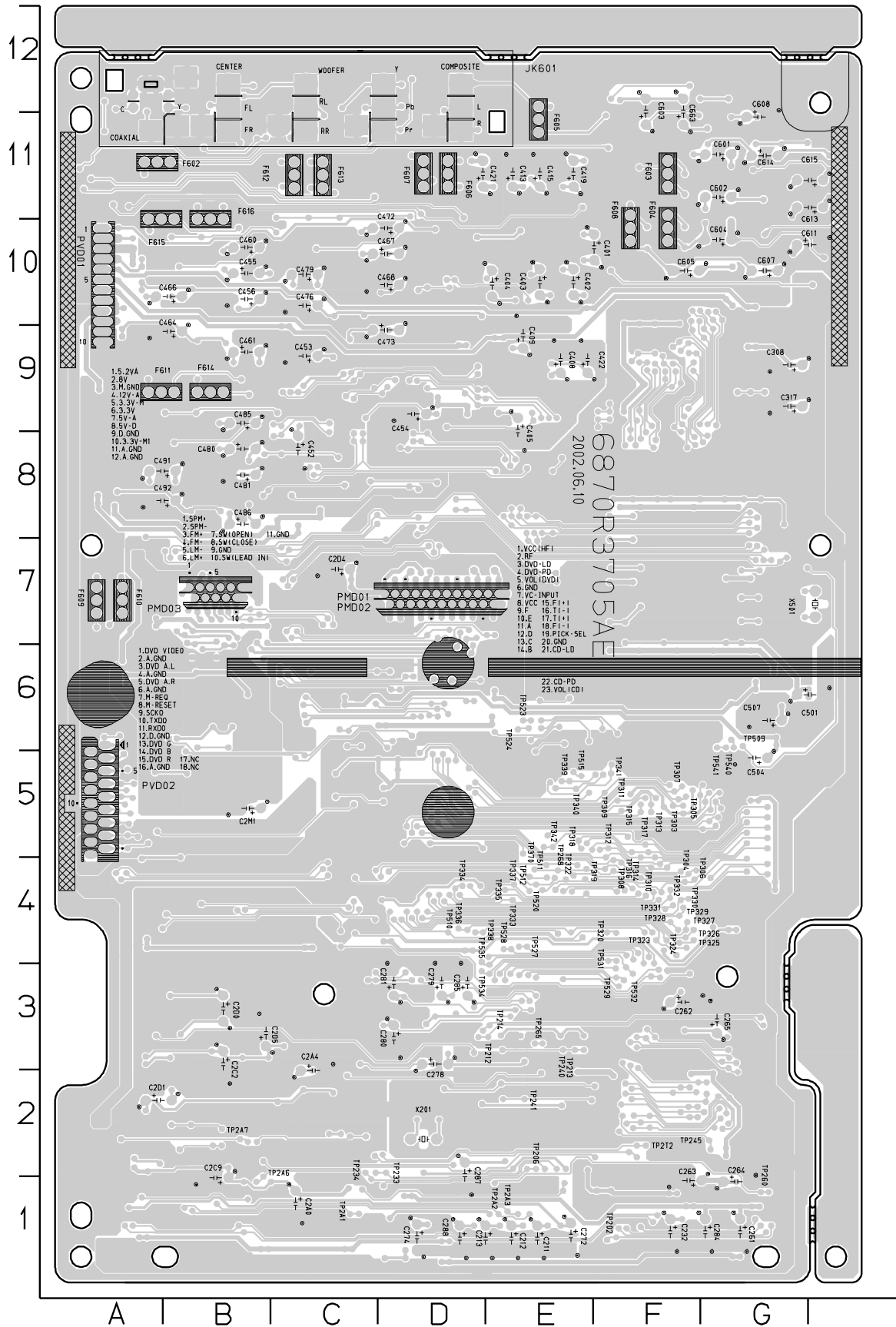

LOCATION GUIDE

TP202	F1
TP206	E2
TP212	E3
TP213	E3
TP214	E3
TP233	D2
TP234	C2
TP240	E3
TP241	E2
TP245	G2
TP260	G1
TP265	E3
TP268	E4
TP2A1	C1
TP2A2	E1
TP2A3	E1
TP2A6	B1
TP2A7	B2
TP2T2	F2
TP303	F5
TP304	F4
TP305	F5
TP306	F4
TP307	F5
TP308	F4
TP309	F5
TP310	F4
TP311	F5
TP312	F5
TP313	F5
TP314	F4
TP315	F5
TP316	F5
TP317	F5
TP318	E5
TP319	E4
TP320	F4
TP322	E4
TP323	F4
TP324	F4
TP325	F4
TP326	F4
TP327	F4
TP328	F4
TP329	F4
TP330	F4
TP331	F4
TP332	F4
TP333	E4
TP334	D4
TP335	E4
TP336	D4
TP337	E4
TP338	D4
TP339	E5
TP340	E5
TP341	F5
TP342	E5
TP370	E5
TP509	G6
TP510	D4
TP511	E4
TP512	E4
TP515	E5
TP520	E4
TP523	E6
TP524	E6
TP527	E4
TP528	E4
TP529	F3
TP531	F4
TP532	F3
TP534	D3
TP535	D4
TP540	G6
TP541	G6

